

HCS_{series} Metal Strip Type Current Sensing Resistors

1. Features	2
2. Applications.....	2
3. Dimension and construction	2
4. Power Derating Curve	3
5. Rating	3
6. Part Number	3
7. Resistance Marking	3
8. Reliability Performance.....	4
9. Packing	5
9.1 Peel Strength of Top Cover Tape.....	5
9.2 Tape Packaging Dimensions.....	5
9.3 Reel Dimensions.....	5

HCS series Metal Strip Type Current Sensing Resistors

1. Features

High power rating and low TCR.
Low resistance and high precision (1%).
Inductance less than 1.0nH.
Excellent reliability and suitable cost.
Suitable for lead free soldering.



2. Applications

Switching model power supply.
Battery pack.
Notebook, personal computer.
Test Instrument.
Power Amplifier.

3. Dimension and construction

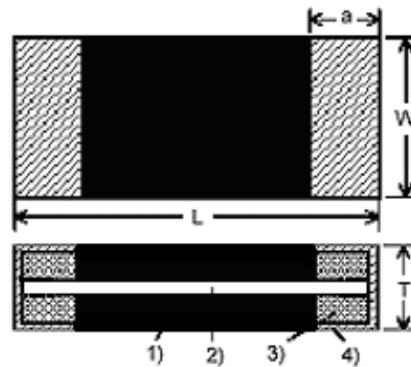
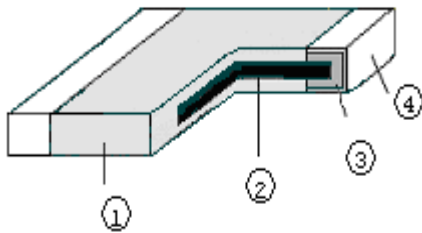

TYPE	1.Protective Coating	2.Resistive Element	3.Terminal	4.Outer Terminal
HCS	Resin	Alloy Metal	Copper	Tin Plating

Type	L	W	T	a
HCS2512 1m,2m	6.20+/-0.25	3.20+/-0.25	0.70+/-0.20	2.0+/-0.30
HCS2512 3m~25m	6.20+/-0.20	3.20+/-0.20	0.60+/-0.20	0.80+/-0.20
HCS2010 5m~20m	5.00+/-0.20	2.50+/-0.20	0.60+/-0.20	0.65+/-0.20
HCS5931 5m	15.00+/-0.20	7.80+/-0.20	0.70+/-0.20	3.50+/-0.20

4. Power Derating Curve

Operating Temperature Range: -55 to +170 deg.C

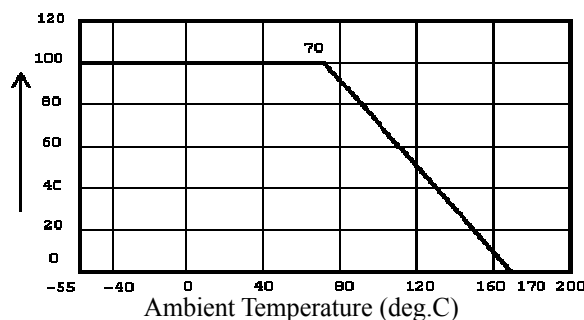

HCS series Metal Strip Type Current Sensing Resistors

5.Rating

Rating Type	Power Rating at 70°C(W)	Max Working Voltage	Max Overload Voltage	Resistance Tolerance (%)	Temperature coefficient of Resistance (ppm/°C)	Resistance Range (mΩ)
HCS2512	1	158mV	316mV	±1%(F) ±5%(J)	±100	1,2,3,4,
					±70	5,6,7,8,9,10,15,20,25
	2	224mV	448mV	±1%(F) ±5%(J)	±100	1,2,3,4,
					±70	5,6,7,8,9,10,15,20,25
HCS2010	1	141mV	282mV	±1%(F) ±5%(J)	±70	5,10,15,20
HCS5931	5	158mV	316mV	±1%(F) ±5%(J)	±70	5

$$E = P * R$$

E : Working Voltage(V) , P : Rated Power (W) , R : Resistance Value(Ω)

6.Part Number

HCS	2512	F	P	H	-	1234
Type	Size	Tolerance	Packing	Watt		R Value
	2512	F: ±1%	P-PlasticTape	H:1W		4 digit
	2010	J : ±5%	4Kpcs	J:2W		
	5931			M:5W		

7.Resistance Marking



For 1~2 mΩ



For 3~25 mΩ

R001 = 1 mΩ

R020 = 20mΩ

HCS series
Metal Strip Type
Current Sensing Resistors

8. Reliability Performance

Test Item	Specification	Test Method
DC Resistance	F : ±1% . J : ±5%	IEC 60115-1 4.5/ JIS C 5202 5.1 Measure the resistance Value.
Short Time Overload	$\Delta R \leq \pm(1\% \pm 0.1m\Omega)$	IEC 60115-1 4.13/ JIS C 5202 5.5 5 × Rated power for 5 seconds
Solderability	Over 95% of termination must be covered with (Sn+Ag+Cu)	IEC 60115-1 4.17 / JIS C 5202 6.5 After immersing flux, dip in the 235±2°C molten solder bath for 2±0.5 sec.
Resistance to solder Heat	$\Delta R \leq \pm(1\% \pm 0.1m\Omega)$ No mechanical damage	IEC 60115-1 4.18 / JIS C 5202 6.4 With 260±5°C for 10±1sec.
Load Life Humidity	$\Delta R \leq \pm(1\% \pm 0.5m\Omega)$	40±2°C with relative humidity 90% ~ 95% D.C. rated voltage for 1.5 hours ON 30 minutes OFF. Cycle repeated 1000 hours.
Temperature Coefficient of Resistance (TCR)	2512:1mΩ~ 4mΩ,TCR:±100PPM 2512:5mΩ~25mΩ,TCR:±70PPM 2010:5mΩ~20MΩ,TCR:±70PPM 5931:±70PPM	IEC 60115-1 4.8.4.2 / JIS C 5202 5.2 T ₁ T ₂ Test temperature : 25°C~-55°C 25°C~+155°C $TCR(ppm/^{\circ}C) = (R_2 - R_1) / R_1 \times 1 / (T_2 - T_1) \times 10^6$
Load Life	$\Delta R \leq \pm(1\% \pm 0.5m\Omega)$	IEC 60115-1 4.25.1 / JIS C 5202 7.10 Rated voltage for 1.5hours for followed by a pause 0.5 hour at 70±2°C. Cycle repeated 1000 hours
Temperature Cycle	$\Delta R \leq \pm(1\% \pm 0.5m\Omega)$ No mechanical damage	IEC 60115-1 4.19 / JIS C 5202 7.4 Repeat 5 cycles as follows -55°C(30min.)+25°C(2~3min.) +155°C(30min.)+25°C(2~3min.)
Insulation Resistance	Between termination and coating must be over 1000MΩ	IEC 60115-1 4.6.1.1 / JIS C 5202 5.6 Test voltage : 100±15V
Bending strength	$\Delta R \leq \pm(1\% \pm 0.5m\Omega)$ No mechanical damage	IEC 60115-1 4.33 Resistance change after bended on the 90mm PCB. Bending :2mm

HCS series Metal Strip Type Current Sensing Resistors

9. PACKAGING

9.1 Peel Strength of Top Cover Tape

The peel speed shall be about 300 mm/min

The peel force of top cover tape shall be between 0.1 to 0.7N

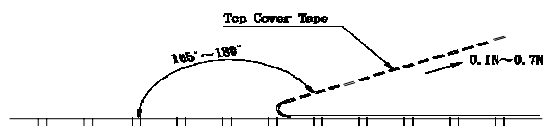

9.2 Tape Packaging Dimensions

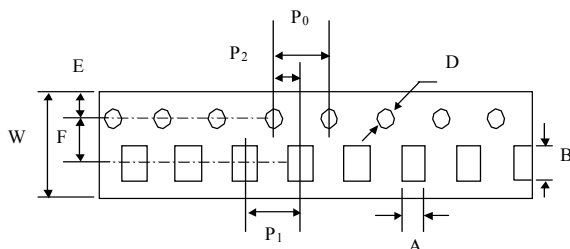

Accumulated dimensional tolerance $40 \pm 0.2 \text{ mm}$

Size	A	B	W	F	E	P1	P2	P0	D
2512	3.70 ± 0.20	6.75 ± 0.20	12.00 ± 0.30	5.50 ± 0.05	1.75 ± 0.10	4.00 ± 0.10	2.00 ± 0.05	4.00 ± 0.10	$1.50 + 0.10 / -0$
2010	2.80 ± 0.20	5.55 ± 0.20	12.00 ± 0.30	5.50 ± 0.05	1.75 ± 0.10	4.00 ± 0.10	2.00 ± 0.05	4.00 ± 0.10	$1.50 + 0.10 / -0$
5931	8.2 ± 0.10	15.4 ± 0.10	24 ± 0.30	11.5 ± 0.10	1.75 ± 0.10	12 ± 0.10	2 ± 0.10	4 ± 0.10	1.5 ± 0.10

unit : mm

9.3 Reel Dimensions

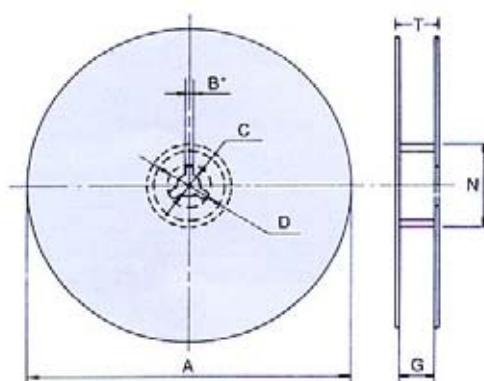

Size	Packaging Q'ty	A	N	C	D	B	G	T
2512	4kpcs/Reel	178.0 ± 2.0	60.0 ± 0.5	13.0 ± 0.5	20(Min.)	2.0 ± 0.5	13.8 ± 1.5	16.7max.
2010	4kpcs/Reel	178.0 ± 2.0	60.0 ± 0.5	13.0 ± 0.5	20(Min.)	2.0 ± 0.5	13.8 ± 1.5	16.7max.
5931	3kpcs/Reel	330.0 ± 2.0	99.5 ± 1.0	13.0 ± 0.5	20(Min.)	2.5 ± 0.5	24.0 ± 1.0	28.6max.