

HHR Series HIGH OHMIC CHIP RESISTORS

■ Features

- Small size and lightweight with size range per int'l standard
- Highly stable in auto-placement surface mounting application
- Compatible with flow and reflow soldering

■ Applications

- Medical or Military equipment
- Printer
- Automotive industry
- Converter
- Power supply in small size

■ Configuration

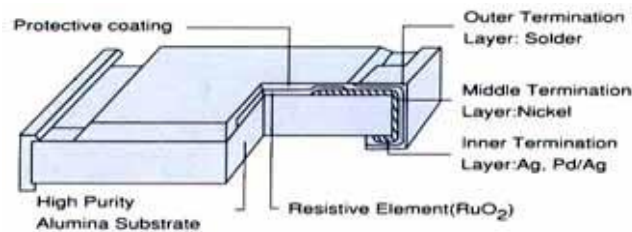

■ Dimensions

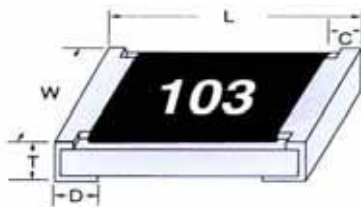

Size	L	W	C	D	T
0603	1.60±0.10	0.80±0.10	0.30±0.20	0.30±0.20	0.45±0.10
0805	2.00±0.15	1.20±0.15	0.40±0.20	0.40±0.20	0.50±0.10
1206	3.10±0.15	1.60±0.15	0.50±0.25	0.50±0.25	0.55±0.10

(unit: mm)

■ Power Derating Curve

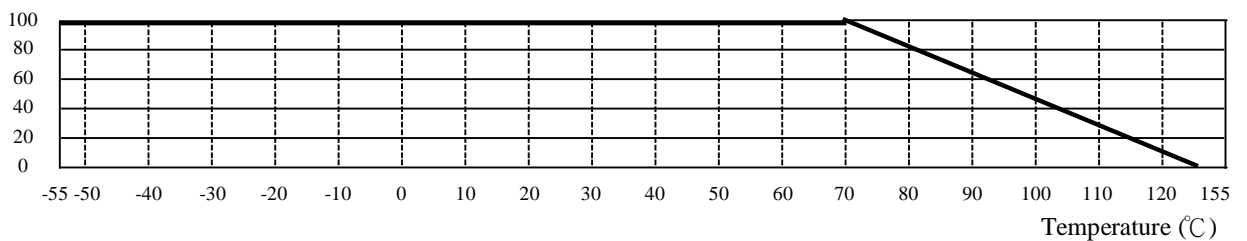

For resistors operated in ambient temperatures over 7°C, power rating shall be derated in accordance with the curve above

HHR Series

HIGH OHMIC CHIP RESISTORS

SPECIFICATION

■ Rating

FHF Series

• HIGH RESISTANCE CHIP RESISTORS

Type	Size	Power Rating at 70°C	Max. RCWV	Max. Overload Voltage	Resistance Tolerance (%)	Temperature Coefficient (TCR; ppm/°C)	Resistance Range		Standard Resistance Values
							Min.	Max.	
HHR0603	0603	1/10W	50V	100	±5%(J)	±200	11MΩ	100MΩ	E-12
HHR0805	0805	1/8W	150V	300					
HHR1206	1206	1/4W	200V	400					

■ Part Number

HHR	0805	J	R	-	476
Type	Size	Tolerance	Packing		GM
	0603	J : ± 5%	R : Paper tape - 5Kpcs		
	0805		V : Paper tape - 10Kpcs		
	1206		W : Paper tape - 20Kpcs		

■ Resistance Marking

• E - 12 SERIES

3 digit marking for ±5% E12



examples : **476** $47 \times 10^6 = 47M\Omega$

HHR Series HIGH OHMIC CHIP RESISTORS

SPECIFICATION

■ Tape And Reel Package

- Taping specs are according to EIA RS-481

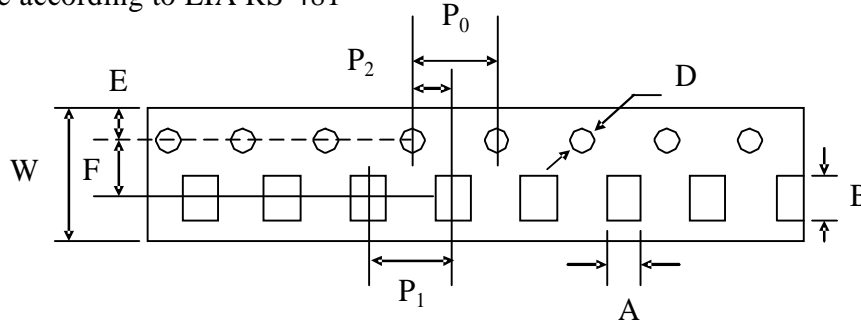

Accumulated dimensional tolerance $40\pm 0.2\text{mm}$

Size	A	B	W	F	E	P1	P2	P0	D
0603	1.10 ± 0.20	1.90 ± 0.20	8.00 ± 0.30	3.50 ± 0.05	1.75 ± 0.10	4.00 ± 0.10	2.00 ± 0.05	4.00 ± 0.10	$1.50+0.10/-0$
0805	1.65 ± 0.20	2.40 ± 0.20	8.00 ± 0.30	3.50 ± 0.05	1.75 ± 0.10	4.00 ± 0.10	2.00 ± 0.05	4.00 ± 0.10	$1.50+0.10/-0$
1206	2.00 ± 0.20	3.60 ± 0.20	8.00 ± 0.30	3.50 ± 0.05	1.75 ± 0.10	4.00 ± 0.10	2.00 ± 0.05	4.00 ± 0.10	$1.50+0.10/-0$

(unit: mm)

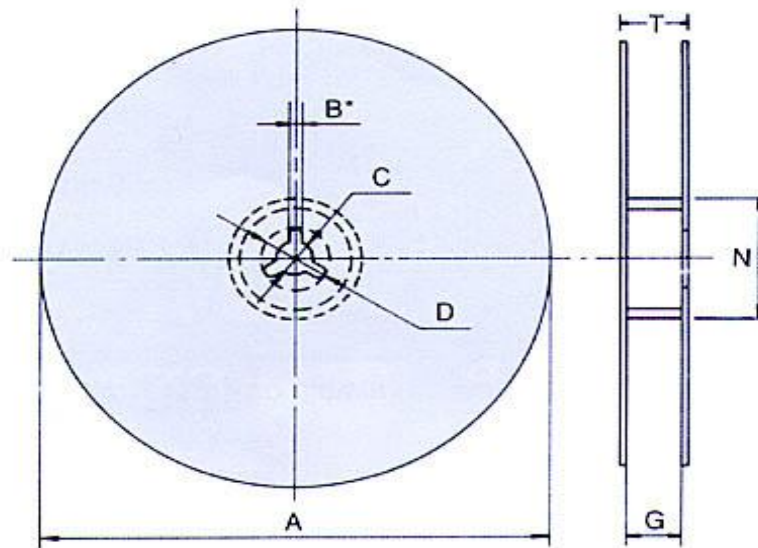

Size	Packaging Q'ty	A	N	C	D	B	G	T
0603	5Kpcs / Reel	178.0 ± 2.0	60.0 ± 0.5	13.0 ± 0.5	20min	2.0 ± 0.5	10.0 ± 1.5	14.9 max.
0805	10Kpcs / Reel	254.0 ± 2.0	100.0 ± 1.0	13.5 ± 0.5	20min	2.0 ± 0.5	10.0 ± 1.5	14.9 max.
1206	20Kpcs / Reel	330.0 ± 2.0	100.0 ± 1.0	13.5 ± 0.5	20min	2.0 ± 0.5	10.0 ± 1.5	14.9 max.

HHR Series

HIGH OHMIC CHIP RESISTORS

SPECIFICATION

■ Specification And Test Methods

ITEM	SPECIFICATION	TEST METHOD
DC Resistance	J: $\pm 5\%$	IEC 115-1 4.5 / JIS C 5202 5.1 Measure the resistance value.
Short time Overload	J: $\Delta R \leq \pm 2\%$	IEC 115-1 4.13 / JIS C 5202 5.5 2.5×Rated voltage or Max. Overload Voltage for 5 sec. measure resistance after 30 minutes
Solderability	Over 95% of termination must be covered with solder	IEC 115-1 4.17 / JIS C 5202 6.5 After immersing flux, dip in the 235±2 °C molten solder bath for 2±0.5 sec.
Resistance to Solder Heat	J: $\Delta R \leq \pm 2\%$	IEC 115-1 4.18 / JIS C 5202 6.4 With 255±5 °C for 10±1 sec.
Temperature Coefficient of Resistance (TCR)	J: $\pm 200 \text{ ppm}/^\circ\text{C}$	IEC 115-1 4.8.4.2 / JIS C 5202 5.2 Test temperature : 25°C (T1) → -55°C (T2) 25°C (T1) → +155°C $\text{TCR (ppm}/^\circ\text{C)} = \frac{(T2) R2 - R1}{R1} \times \frac{1}{T2 - T1} \times 10^6$ T1: 25°C T2: Test temperature R1: Resistance at reference temperature (T1) R2: Resistance at test temperature (T2)
Load Life Humidity	J: $\Delta R \leq \pm 5\%$	IEC 115-1 4.24.2 / JIS C 5202 7.9 Maintain the temperature of the resistor at 40±2 °C and 90~95% R.H. with the rated voltage applied. Cycle ON for 1.5 hours and OFF for 0.5 hour for 1000+48/-0 hours. After 1~4 hour, measure the resistance value.
Load Life	J: $\Delta R \leq \pm 5\%$	IEC 115-1 4.25.1 / JIS C 5202 7.10 Permanent resistance change after 1000+48/-0 hours (1.5 hours ON , 0.5 hour OFF) at RCWV or Max. Keep the resistor at 70±2 °C ambient
Temperature Cycle	J: $\Delta R \leq \pm 5\%$	IEC 115-1 4.19 / JIS C 5202 7.4 Repeat 5 cycles as follows '-55°C (30 min.) + 25 °C (2~3 min.) +155°C (30 min.) + 25 °C (2~3 min.)
Insulation Resistance	Between termination and coating must be over 1000MΩ	IEC 115-1 4.6.1.1 / JIS C 5202 5.6 Test voltage: 100±15V
Bending Strength	J: $\Delta R \leq \pm 2\%$	IEC 115-1 4.33 Resistance change after bended on the 90mm PCB. Bend: 3mm for 0603、0805, 2mm for 1206,
Voltage Coefficient of Resistance (VCR)	$\leq \pm 300 \text{ ppm}/\text{V}$	JIS C 5202 5.3 Measuring Voltage 10V/100V