

# HMR Series

## MEGA HIGH OHMIC CHIP RESISTORS

### ■ Features

- Extended resistance range ( 110MΩ to 1GΩ )
- Highly stable in auto-placement surface mounting application
- Highly reliable multilayer electrode construction.

### ■ Applications

- Low signal detection or amplification circuit.
- X-ray equipment
- Testing device
- Voltage dividers and hybrid.
- High input impedance quartz amplifiers

### ■ Configuration

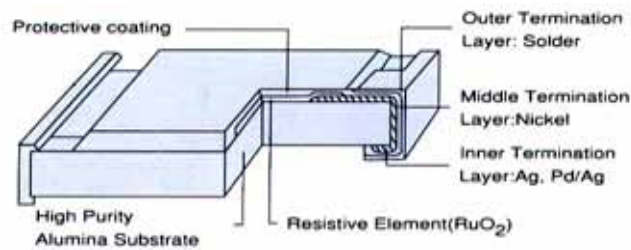

### ■ Dimensions

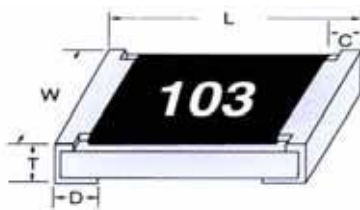

Size	L	W	C	D	T
0805	2.00±0.10	1.25±0.10	0.35±0.20	0.40±0.20	0.50±0.10
1206	3.10±0.10	1.55±0.10	0.50±0.25	0.50±0.25	0.55±0.10

(unit: mm)

### ■ Power Derating Curve

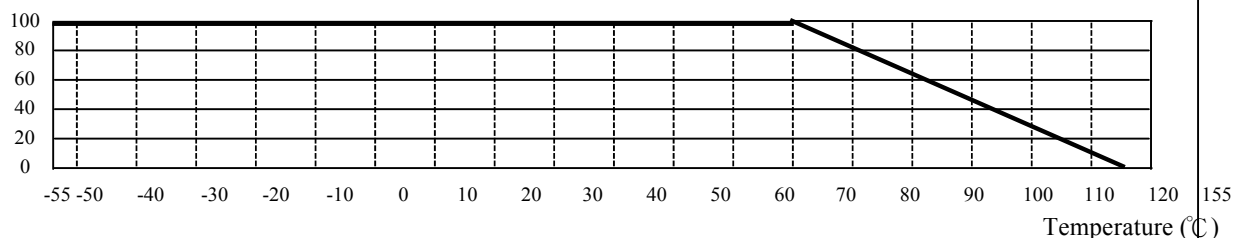

For resistors operated in ambient temperatures over 70°C, power rating shall be derated in accordance with the curve above

# HMR Series

## MEGA HIGH OHMIC CHIP RESISTORS

### SPECIFICATION

#### ■ Rating

##### • MEGA HIGH OHMIC CHIP RESISTOR

Type	Size	Power Rating at 70°C	Max. RCWV	Max. Overload Voltage	Resistance Tolerance (%)	Temperature Coefficient (TCR; ppm/°C)	Resistance Range
HMR0805	0805	1/8W	150V	300V	5%	±500	110MΩ~500MΩ
						±1000	510MΩ~1GΩ
HMR1206	1206	1/4W	200V	400V		±500	110MΩ~500MΩ
						±1000	510MΩ~1GΩ

#### ■ Part Number

<u>HMR</u>	<u>0805</u>	<u>J</u>	<u>R</u>	-	<u>477</u>
Type	Size	Tolerance	Packing		GM
	0805	J : ± 5%	R : Paper tape - 5Kpcs		
	1206				

#### ■ Resistance Marking

##### • E - 12 SERIES

3 digit marking for ±5% E12



examples : **477**  $47 \times 10^7 = 470M\Omega$

# HMR Series

## MEGA HIGH OHMIC CHIP RESISTORS

### SPECIFICATION

#### ■ Tape And Reel Package

- Taping specs are according to EIA RS-481

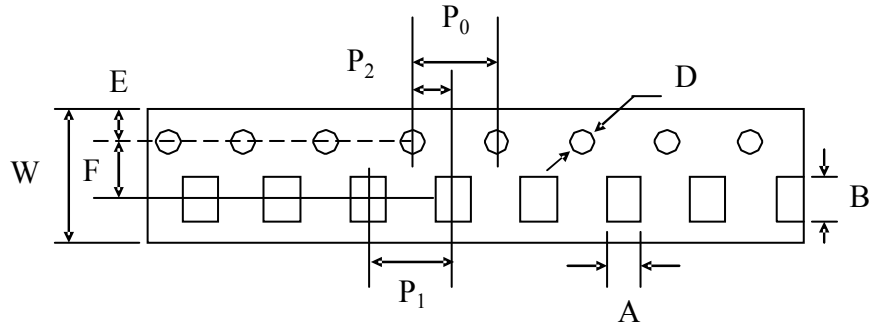

Accumulated dimensional tolerance  $40 \pm 0.2 \text{mm}$

Size	A	B	W	F	E	P1	P2	P0	D
0805	$1.65 \pm 0.20$	$2.40 \pm 0.20$	$8.00 \pm 0.30$	$3.50 \pm 0.05$	$1.75 \pm 0.10$	$4.00 \pm 0.10$	$2.00 \pm 0.05$	$4.00 \pm 0.10$	$1.50 + 0.10 / - 0$
1206	$2.00 \pm 0.20$	$3.60 \pm 0.20$	$8.00 \pm 0.30$	$3.50 \pm 0.05$	$1.75 \pm 0.10$	$4.00 \pm 0.10$	$2.00 \pm 0.05$	$4.00 \pm 0.10$	$1.50 + 0.10 / - 0$

(unit: mm)

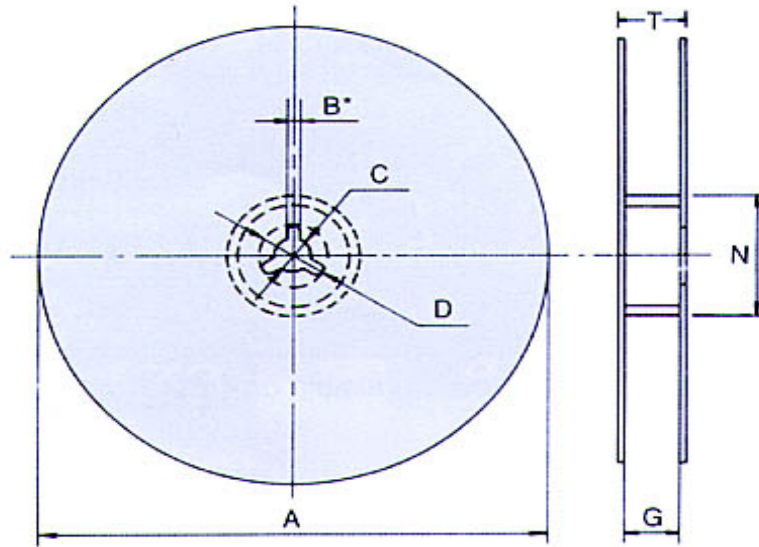

Size	Packaging Q'ty	A	N	C	D	B	G	T
0805 & 1206	5Kpcs / Reel	$178.0 \pm 2.0$	$60.0 \pm 0.5$	$13.0 \pm 0.5$	20min	$2.0 \pm 0.5$	$10.0 \pm 1.5$	14.9 max.

# HMR Series

## MEGA HIGH OHMIC CHIP RESISTORS

### SPECIFICATION

#### ■ Specification And Test Methods

ITEM	SPECIFICATION	TEST METHOD
DC Resistance	J: $\pm 5\%$	Measure the resistance value.
Short time Overload	J: $\Delta R \leq \pm 2\%$	2.5×Rated voltage or Max. Overload Voltage for 5 sec. measure resistance after 30 minutes
Solderability	Over 95% of termination must be covered with solder	After immersing flux, dip in the 235±2 °C molten solder bath for 2±0.5 sec.
Resistance to Solder Heat	J: $\Delta R \leq \pm 2\%$	With 260±5°C for 10±1 sec.
Temperature Coefficient of Resistance (TCR)	As Specification	Test temperature : 25°C (T1) → -55°C (T2) 25°C (T1) → +125°C(T2) $TCR (ppm/^{\circ}C) = \frac{R2-R1}{R1} \times \frac{1}{T2-T1} \times 10^6$ T1: 25°C T2: Test temperature R1: Resistance at reference temperature (T1) R2: Resistance at test temperature (T2)
Load Life Humidity	J: $\Delta R \leq \pm 5\%$	Maintain the temperature of the resistor at 40±2 °C and 90~95% R.H. with the rated voltage applied. Cycle ON for 1.5 hours and OFF for 0.5 hour for 1000+48/-0 hours. After 1~4 hour, measure the resistance value.
Load Life	J: $\Delta R \leq \pm 5\%$	Permanent resistance change after 1000+48/-0 hours (1.5 hours ON, 0.5 hour OFF) at RCWV or Max. W.V, Keep the resistor at 70±2°C ambient temp.
Temperature Cycle	J: $\Delta R \leq \pm 5\%$	Repeat 5 cycles as follows -55°C(30 min.) + 25 °C(2~3 min.) +155°C(30 min.) + 25 °C(2~3 min.)
Insulation Resistance	Between termination and coating must be over 10 GΩ	Max overload voltage for 1 minute
Bending Strength	J: $\Delta R \leq \pm 2\%$	Bending once for 5 seconds. Bend: 3mm for 0805 , 2mm for 1206 ,
Voltage Proof	No breakdown or flashover	1.42 times RCWV (RMS) for 1 minutes