

**HPF** series  
Thick-Film Type  
High-Power Chip Resistors > 1R

1. SCOPE.....	2
Purpose.....	2
Configuration.....	2
Part Number.....	2
2. PERFORMANCE CHARACTERISTICS.....	3
2.1 Power Derating Curve by Ambient Temperature.....	3
2.2 Mechanical Dimensions.....	3
2.3 Recommended Solder-Pad Dimensions.....	3
3. SPECIFICATION.....	4
3.1 Electrical Characteristic.....	4
3.2 Reliability Performance.....	4~5
4. PACKAGING.....	5
Peel Strength of Top Cover Tape.....	5
Tape Packaging Dimensions.....	6
Reel Dimensions.....	6

# HPF series Thick-Film Type High-Power Chip Resistors > 1R

## 1. SCOPE

### 1.1 Purpose

Fixed Thick-Film High-Power Chip Resistors, Rated Power up to 2W, used in Consumer Electronics, SMPS, M/B, electronic equipment.

### 1.2 Configuration

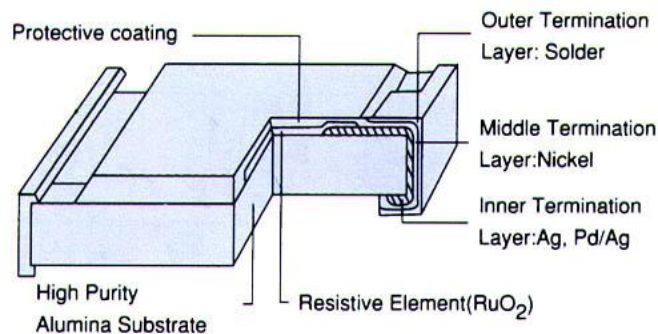

### 1.3 Part Number:

HPF	2512	J	R	- 100R
Type	Size	Tolerance	Packing	OHMIC VALUE
	0603	F : ± 1%	R : Paper tape – 5 Kpcs	IN OHM (Ω)
	0805	J : ± 5%	K : Plastic tape – 4 Kpcs	For example :
	1206			100R = 100Ω
	2010			100KR = 100KΩ
	2512			

### ■ Resistance Marking

**301**

3 digit marking for E-24 ±5% 0603 0805 1206 2010 2512

examples : **301**  $30 * 10^1 = 300 \Omega$

**1542**

4 digit marking for E96 ±1% 0805 1206 2010 2512

examples : **1542**  $154 * 10^2 = 15.4K \Omega$

**222**

3 digit marking for E24 ±1% 0603

examples : **222**  $222 * 10^2 = 22.2K \Omega$

**01C**

3 digit marking for E96 ±1% 0603

examples : **01C**  $10K \Omega$

**HPF** series  
**Thick-Film Type**  
**High-Power Chip Resistors > 1R**

2. PERFORMANNCE CHARCTERISTICS

Power Derating Curve by Ambient Temperature  
 Rated Load (%)

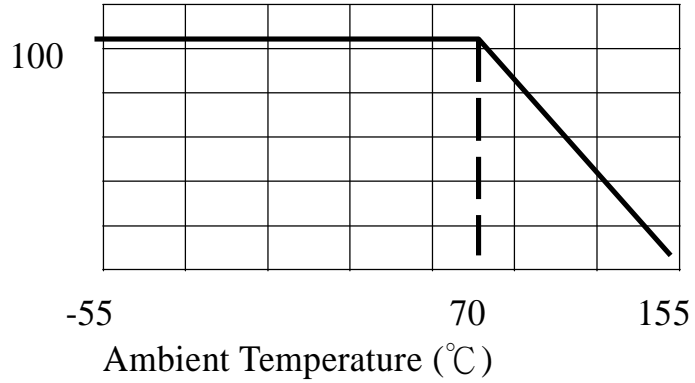

Mechanical Dimensions

unit: mm.

Type	DIMENSIONS				
	L	W	C	D	T
HPF0603	1.60±0.10	0.80±0.10	0.30±0.20	0.30±0.20	0.45±0.10
HPF0805	2.00±0.15	1.20±0.15	0.40±0.20	0.40±0.20	0.50±0.10
HPF1206	3.10±0.15	1.60±0.15	0.50±0.25	0.50±0.25	0.55±0.10
HPF2010	5.00±0.20	2.50±0.20	0.60±0.25	0.60±0.25	0.60±0.10
HPF2512	6.30±0.20	3.10±0.20	0.60±0.25	1.80±0.25	0.60±0.15

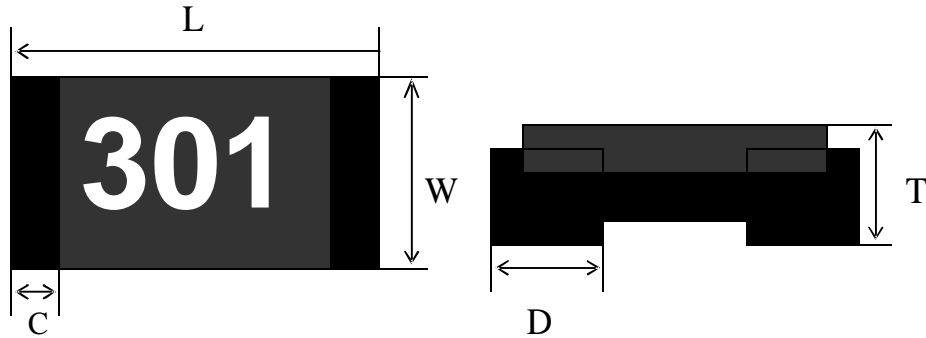

Recommended Solder Pad Dimensions

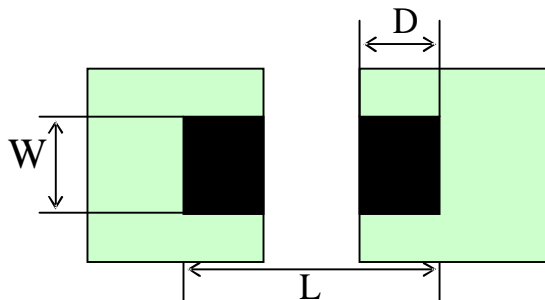

Type	W	D	L
HPF2512	3.7mm	2.45mm	7.6mm

**HPF** series  
**Thick-Film Type**  
**High-Power Chip Resistors > 1R**

**3. SPECIFICATION**

**Electrical Characteristic**

Type	Size	Power Rating at 70°C	Max. RC WV	Max. Overload Voltage	Resistance Tolerance (%)	Temperature Coefficient (TCR; ppm/°C)	Resistance Range (Ω)		Standard Resistance Values
							Min.	Max.	
HPF0603	0603	1/8W	50V	100V	±1%(F)	±100	10Ω	1MΩ	E-96
HPF0805	0805	1/4W	150V	300V					
HPF1206	1206	1/2W	200V	400V	±5%(J)	±200	0Ω , 1Ω	1MΩ	E-24
HPF2010	2010	1W	200V	400V					
HPF2512	2512	2W	300V	600V					

**Note :**

(\*)2W loading with total solder-pad and trace size of 300 mm<sup>2</sup>

(\*\*) E = (P×R)<sup>1/2</sup>

E : Working Voltage(V) , P : Rated Power(W) , R : Resistance Value(Ω)

**Reliability Performance**

Test Item	Specification	Test Method
DC Resistance	F : ±1% ; J : ±5%	IEC 60115-1 / JIS C 5201-1 , Clause 4.5 Measure the resistance Value.
Short Time Overload	J: ΔR ≤ ±(2% + 0.1 Ω) F: ΔR ≤ ±(1% + 0.05 Ω)	5 × Rated power for 5 seconds
Solderability	Over 95% of termination must be covered with solder	IEC 60115-1 / JIS C 5201-1, Clause 4.17 After immersing flux, dip in the 235±2°C
Resistance to solder Heat	J: ΔR ≤ ±(1% + 0.1 Ω) F: ΔR ≤ ±(0.5% + 0.05 Ω) No mechanical damage	IEC 60115-1 / JIS C 5201-1 , Clause 4.18 With 260±5°C for 10±1sec.
Load Life Humidity	J: ΔR ≤ ±(3% + 0.1 Ω) F: ΔR ≤ ±(1% + 0.05 Ω)	40±2°C with relative humidity 90% ~ 95% D.C. rated voltage for 1.5 hours ON 30 minutes OFF. Cycle repeated 1000 hours.
Temperature Coefficient of Resistance (TCR)	F: ± 100ppm/°C J: ± 200ppm/°C	IEC 60115-1 / JIS C 5201-1 , Clause 4.8 T <sub>1</sub> T <sub>2</sub> Test temperature : 25°C ~ -55°C 25°C ~ +155°C TCR(ppm/°C) = (R <sub>2</sub> -R <sub>1</sub> )/R <sub>1</sub> × 1 / (T <sub>2</sub> -T <sub>1</sub> ) × 10 <sup>6</sup>

**HPF** series  
**Thick-Film Type**  
**High-Power Chip Resistors > 1R**

Load Life	J : $\Delta R \leq \pm(3\% + 0.1 \Omega)$ F : $\Delta R \leq \pm(1\% + 0.05 \Omega)$	IEC 60115-1 / JIS C 5201-1 , Clause 4.25 Rated voltage for 1.5 hours for followed by a pause 0.5 hour at $70 \pm 3^\circ\text{C}$ . Cycle repeated 1000 hours
Temperature Cycle	J : $\Delta R \leq \pm(1\% + 0.1 \Omega)$ F : $\Delta R \leq \pm(0.5\% + 0.05 \Omega)$ No mechanical damage	IEC 60115-1 / JIS C 5201-1, Clause 4.19 Repeat 5 cycles as follows $-55^\circ\text{C}$ (30min.) $+25^\circ\text{C}$ (2~3min.) + $155^\circ\text{C}$ (30min.) $+25^\circ\text{C}$ (2~3min.)
Insulation Resistance	Between termination and coating must be over $1000\text{M}\Omega$	IEC 60115-1 / JIS C 5201-1 , Clause 4.6 Test voltage : $100 \pm 15\text{V}$
Bending strength	J : $\Delta R \leq \pm(1\% + 0.1 \Omega)$ F : $\Delta R \leq \pm(0.5\% + 0.05 \Omega)$ No mechanical damage	IEC 60115-1 / JIS C 5201-1 , Clause 4.33 Resistance change after bended on the 90mm PCB. Bending width : 3mm for 0603 0805 2mm for 1206 2010 2512

**4. PACKAGING**

**Peel Strength of Top Cover Tape**

The peel speed shall be about 300 mm/min

The peel force of top cover tape shall between 0.1 to 0.7N

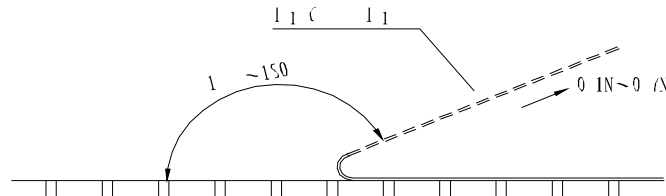

**4.2 Tape Packaging Dimensions**

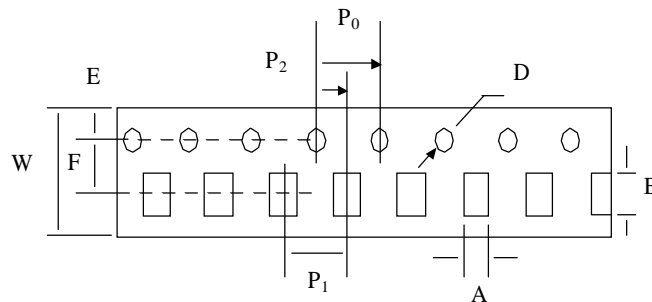

Accumulated dimensional tolerance  $40 \pm 0.2\text{mm}$

**HPF** series  
**Thick-Film Type**  
**High-Power Chip Resistors > 1R**

Size	A	B	W	F	E	P1	P2	P0	D
0603	1.10±0.20	1.90±0.20	8.00±0.30	3.50±0.05	1.75±0.10	4.00±0.10	2.00±0.05	4.00±0.10	1.50+0.10/-0
0805	1.65±0.20	2.40±0.20	8.00±0.30	3.50±0.05	1.75±0.10	4.00±0.10	2.00±0.05	4.00±0.10	1.50+0.10/-0
1206	2.00±0.20	3.57±0.20	8.00±0.30	3.50±0.05	1.75±0.10	4.00±0.10	2.00±0.05	4.00±0.10	1.50+0.10/-0
2010	2.80±0.20	5.50±0.20	12.00±0.30	5.50±0.05	1.75±0.10	4.00±0.10	2.00±0.05	4.00±0.10	1.50+0.10/-0
2512	3.50±0.20	6.70±0.20	12.00±0.30	5.50±0.05	1.75±0.10	4.00±0.10	2.00±0.05	4.00±0.10	1.50+0.10/-0

unit : mm

4.3 Reel Dimensions

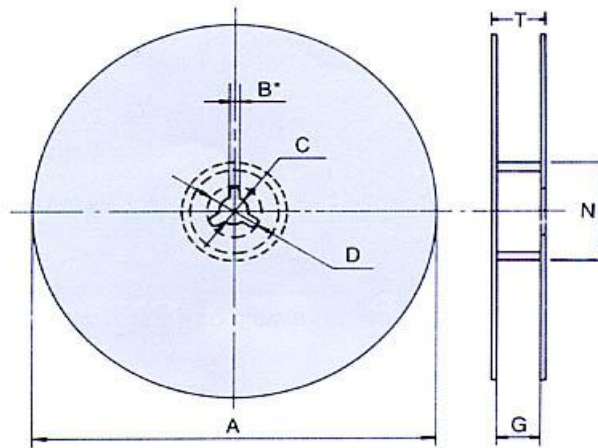

Size	Packaging Q'ty	A	N	C	D	B	G	T
0603 0805 1206	5kpcs/Reel	178.0±2.0	60.0±0.5	13.0±0.5	20(Min.)	2.0±0.5	10.0±1.5	14.9max.
2010 2512	4kpcs/Reel	178.0±2.0	60.0±0.5	13.0±0.5	20(Min.)	2.0±0.5	13.8±1.5	16.7max.

unit : mm