

# HSR Series

## Thick Film Surge Chip Resistors

### ■ Features

- Small size and lightweight with size range per int'l standard
- Highly stable in auto-placement surface mounting application
- Suitable for withstanding circuit for surge voltage

### ■ Applications

- CD-ROM
- Power supply
- Automotive industry
- Measurement instrument
- Medical or Military equipment
- Electronic watch and camera

### ■ Configuration

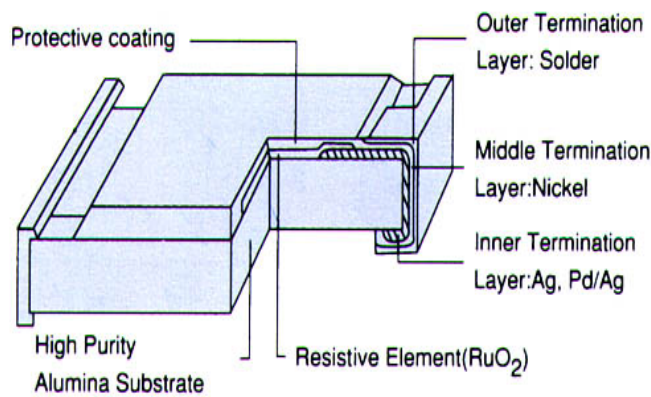

### ■ Dimensions

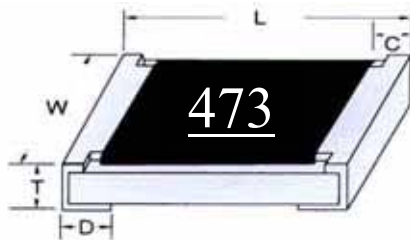

Size	L	W	C	D	T
0603	1.60±0.10	0.80±0.10	0.30±0.20	0.30±0.20	0.45±0.10
0805	2.00±0.15	1.20±0.15	0.40±0.20	0.40±0.20	0.50±0.10
1206	3.10±0.15	1.60±0.15	0.50±0.25	0.50±0.25	0.55±0.10
2010	5.00±0.20	2.50±0.20	0.60±0.25	0.60±0.25	0.60±0.10
2512	6.30±0.20	3.10±0.20	0.60±0.25	0.60±0.25	0.60±0.15

(unit: mm)

### ■ Power Derating Curve

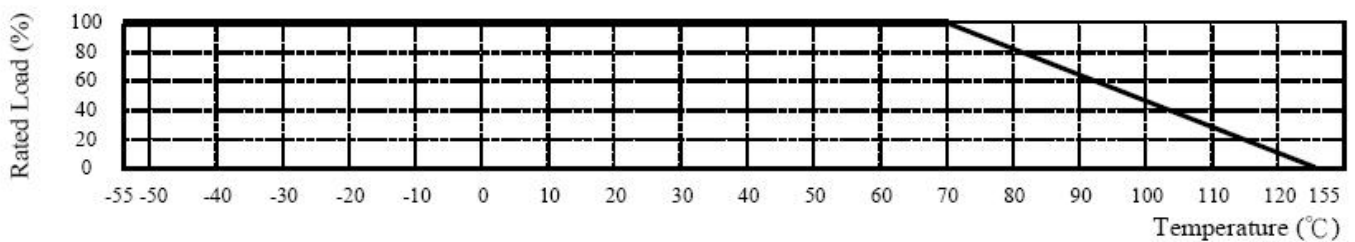

For resistors operated in ambient temperatures over 70°C, power rating shall be derated in accordance with the curve above.

# HSR Series

## Thick Film Surge Chip Resistor

### Rating

Type	Size	Power Rating at 70°C	Max. RCWV	Max. Overload Voltage	Resistance Tolerance (%)	Temperature Coefficient (TCR; ppm/°C)	Resistance Ra		Standard Resistance Values
							Min.	Max.	
HSR0603	0603	1/10W	50V	100V	±1%(F) ±5%(J) ±10%(K) ±15%(L) ±20%(M)	±100	1Ω	1MΩ	E-24
HSR0805	0805	1/8W	150V	300V					
HSR1206	1206	1/4W	200V	400V					
HSR2010	2010	1/2W	200V	400V					
HSR2512	2512	1W	200V	400V					

### Surge Performance

1206, 2010, 2512

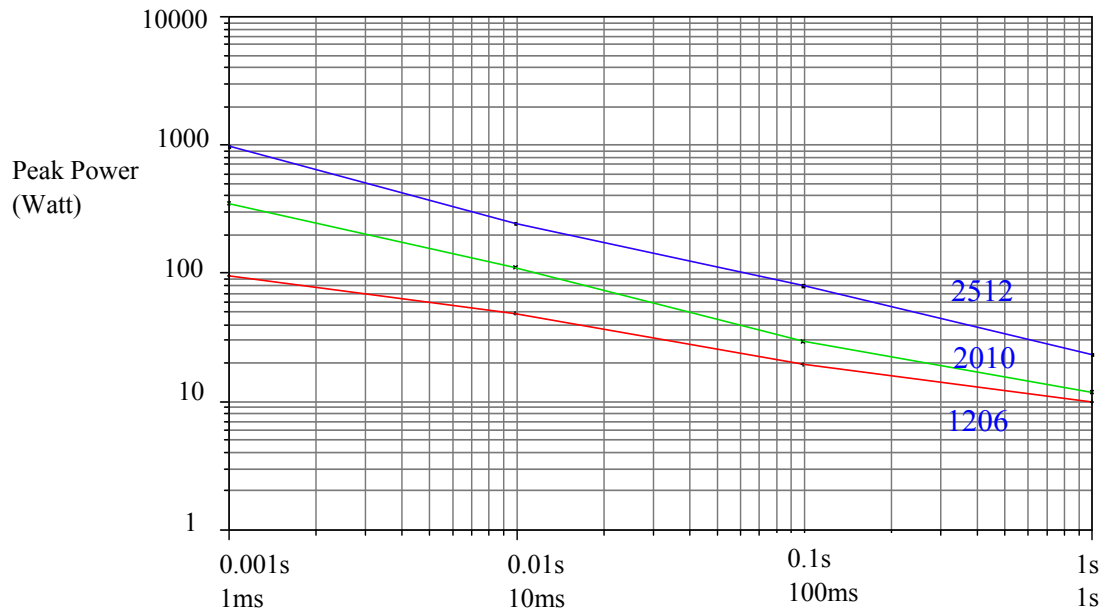

### Surge duration

### Part Number

HSR	0805	J	R	-	473
Type	Size	Tolerance	Packing		GM
	0603	F : ± 1%	R : Paper tape- 5Kpcs		
	0805	J : ± 5%	K : Plastic tape- 4Kpcs		
	1206	K : ± 10%			
	2010	L : ± 15%			
	2512	M : ± 20%			

### Resistance Marking

• E - 24 SERIES

3 digit marking

Underline for identification surge resistors

examples: 473  $47 \times 10^3 = 47K\Omega$



# HSR Series

## Thick Film Surge Chip Resistor

### SPECIFICATION

#### ■ Tape And Reel Package

- Taping specs are according to EIA RS-481

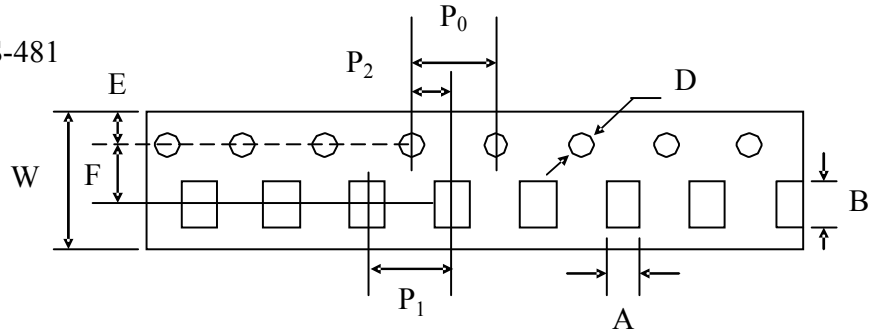

Accumulated dimensional tolerance  $40\pm 0.2\text{mm}$

Size	A	B	W	F	E	P1	P2	P0	D
0603	$1.10\pm 0.20$	$1.90\pm 0.20$	$8.00\pm 0.30$	$3.50\pm 0.05$	$1.75\pm 0.10$	$4.00\pm 0.10$	$2.00\pm 0.05$	$4.00\pm 0.10$	$1.50+0.10/-0$
0805	$1.65\pm 0.20$	$2.40\pm 0.20$	$8.00\pm 0.30$	$3.50\pm 0.05$	$1.75\pm 0.10$	$4.00\pm 0.10$	$2.00\pm 0.05$	$4.00\pm 0.10$	$1.50+0.10/-0$
1206	$2.00\pm 0.20$	$3.60\pm 0.20$	$8.00\pm 0.30$	$3.50\pm 0.05$	$1.75\pm 0.10$	$4.00\pm 0.10$	$2.00\pm 0.05$	$4.00\pm 0.10$	$1.50+0.10/-0$
2010	$2.80\pm 0.20$	$5.50\pm 0.20$	$12.00\pm 0.30$	$5.50\pm 0.05$	$1.75\pm 0.10$	$4.00\pm 0.10$	$2.00\pm 0.05$	$4.00\pm 0.10$	$1.50+0.10/-0$
2512	$3.50\pm 0.20$	$6.70\pm 0.20$	$12.00\pm 0.30$	$5.50\pm 0.05$	$1.75\pm 0.10$	$4.00\pm 0.10$	$2.00\pm 0.05$	$4.00\pm 0.10$	$1.50+0.10/-0$

(unit: mm)

- Reel Package

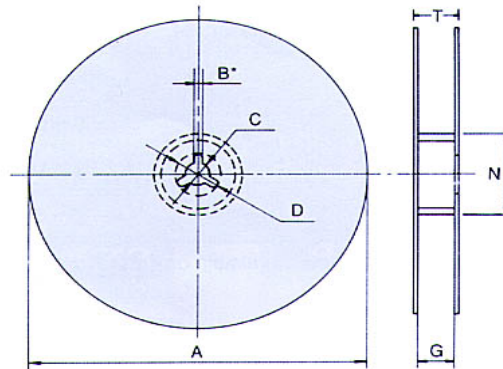

Size	Packaging Q'ty	A	N	C	D	B	G	T
0603	5Kpcs / Reel	$178.0\pm 2.0$	$60.0\pm 0.5$	$13.0\pm 0.5$	20min	$2.0\pm 0.5$	$10.0\pm 1.5$	14.9 max.
0805	10Kpcs / Reel	$254.0\pm 2.0$	$100.0\pm 1.0$	$13.5\pm 0.5$	20min	$2.0\pm 0.5$	$10.0\pm 1.5$	14.9 max.
1206	20Kpcs / Reel	$330.0\pm 2.0$	$100.0\pm 1.0$	$13.5\pm 0.5$	20min	$2.0\pm 0.5$	$10.0\pm 1.5$	14.9 max.
2010	4Kpcs / Reel	$178.0\pm 2.0$	$60.0\pm 0.5$	$13.0\pm 0.5$	20min	$2.0\pm 0.5$	$13.8\pm 1.5$	16.7 max.
2512	8Kpcs / Reel	$254.0\pm 2.0$	$100.0\pm 1.0$	$13.5\pm 0.5$	20min	$2.0\pm 0.5$	$13.8\pm 1.5$	20.0 max.
	16Kpcs / Reel	$330.0\pm 2.0$	$100.0\pm 1.0$	$13.5\pm 0.5$	20min	$2.0\pm 0.5$	$13.8\pm 1.5$	20.0 max.

(unit: mm)

# HSR Series

## Thick Film Surge Chip Resistor

### SPECIFICATION

#### ■ Specification And Test Methods

ITEM	SPECIFICATION	TEST METHOD
DC Resistance	F : ±1%, J : ±5% , K : ±10% , L : ±15% , M : ±20%	IEC 60115-1 4.5 / JIS C 5202 5.1 Measure the resistance value.
Short time Overload	$\Delta R \leq \pm (2\% + 0.1\Omega)$	IEC 60115-1 4.13 / JIS C 5202 5.5 2.5×Rated voltage or Max. Overload Voltage for 5 sec. measure resistance after 30 minutes
Solderability	Over 95% of termination must be covered with solder	IEC 60115-1 4.17 / JIS C 5202 6.5 After immersing flux, dip in the 235±2°C molten solder bath for 2±0.5 sec.
Resistance to Solder Heat	$\Delta R \leq \pm (1\% + 0.1\Omega)$ No mechanical damage	IEC 60115-1 4.18 / JIS C 5202 6.4 With 260±5°C for 10±1 sec.
Temperature Coefficient of Resistance (TCR)	±100 ppm/°C	IEC 60115-1 4.8.4.2 / JIS C 5202 5.2 Test temperature : 25°C (T1) → -55°C (T2) 25°C (T1) → +155°C (T2) R2-R1 1 TCR (ppm/°C) = $\frac{R2-R1}{R1} \times \frac{1}{T2-T1} \times 10^6$ T1: 25°C T2: Test temperature R1: Resistance at reference temperature (T1) R2: Resistance at test temperature (T2)
Load Life Humidity	$\Delta R \leq \pm (3\% + 0.1\Omega)$	IEC 60115-1 4.24.2 / JIS C 5202 7.9 Maintain the temperature of the resistor at 40±2°C and 90~95% R.H. with the rated voltage applied. Cycle ON for 1.5 hours and OFF for 0.5 hour for 1000+48/-0 hours. After 1~4 hour, measure the resistance value.
Load Life	$\Delta R \leq \pm (3\% + 0.1\Omega)$	IEC 60115-1 4.25.1 / JIS C 5202 7.10 Permanent resistance change after 1000+48/-0 hours (1.5 hours ON , 0.5 hour OFF) at RCWV or Max. Keep the resistor at 70±2°C ambient
Intermittent Overload	$\Delta R \leq \pm (5\% + 0.1\Omega)$ No mechanical damage	JIS C 5202 5.8 4.0×Rated voltage (Max. Overload Voltage) 1 sec ON, 25 sec OFF, test 10,000 cycles
Temperature Cycle	$\Delta R \leq \pm (1\% + 0.1\Omega)$ No mechanical damage	IEC 60115-1 4.19 / JIS C 5202 7.4 Repeat 5 cycles as follows -55°C (30 min.) + 25°C (2~3 min.) +155°C (30 min.) + 25°C (2~3 min.)
Insulation Resistance	Between termination and coating must be over 1000MΩ	IEC 60115-1 4.6.1.1 / JIS C 5202 5.6 Test voltage: 100±15V
Bending Strength	$\Delta R \leq \pm (1\% + 0.1\Omega)$ No mechanical damage	IEC 60115-1 4.33 Resistance change after bended on the 90mm PCB. Bend: 3mm for 0603、0805, 2mm for 1206, 2010, 2512