

PPS SERIES

Polypropylene Film Capacitor.(high voltage)

FEATURES

- Non-inductive construction.
- Self-healing property.
- Two capacitors are wound in series connection at the same time which will minimize the unbalance voltage distribution.
- High corona starting voltage.
- Large current rating and high maximum pulse rise time.
- Flame-retardant epoxy resin coating (UL 94V-O)

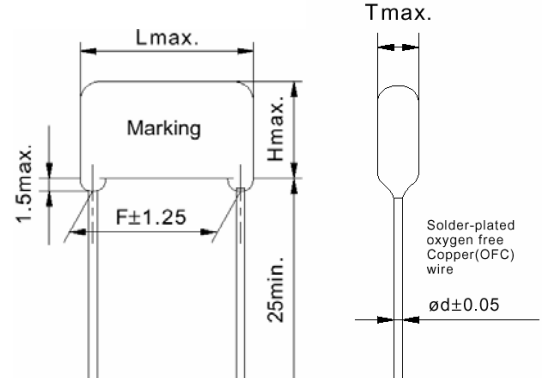

SPECIFICATIONS

1. OPERATING TEMPERATURE: -40°C ~ +85°C
2. CAPACITANCE RANGE: See Table
3. CAPACITANCE TOLERANCE: ±5%(J), ±10%(K)
4. RATED VOLTAGE: See Table
5. DISSIPATION FACTOR: 0.1% max. at 1KHz, 20°C
6. WITHSTAND VOLTAGE 200% of the Rated Voltage for 1~5 Sec.
7. INSULATION RESISTANCE: Measured at 500V.DC, 60 Sec. Between Terminals: >=30,000 MΩ
8. Load life Test : Will withstand the test of R.H. 95% at 40 °C for 100hrs. After the test, the capacitance drift less than 3%, D.F. less than 0.2%, I.R. >= 1,000 MΩ-uF or 10,000 MΩ whichever is smaller.

Unit : :mm

RV SIZE CAP.(uF)	1000VDC				1200VDC				1600VDC				2000VDC			
	L	H	T	F	L	H	T	F	L	H	T	F	L	H	T	F
0.001	25.0	10.5	6.0	21.0	25.0	10.5	6.0	21.0	25.0	11.0	6.5	21.0	25.0	12.5	7.0	21.0
0.0012	25.0	11.0	6.0	21.0	25.0	11.0	6.0	21.0	25.0	11.5	6.5	21.0	25.0	13.0	7.5	21.0
0.0015	25.0	11.5	6.0	21.0	25.0	11.5	6.5	21.0	25.0	12.5	7.0	21.0	25.0	14.0	8.0	21.0
0.0018	25.0	11.5	6.0	21.0	25.0	12.0	7.0	21.0	25.0	13.5	7.5	21.0	25.0	16.0	8.5	21.0
0.0022	25.0	11.5	6.5	21.0	25.0	12.5	7.5	21.0	25.0	15.0	8.0	21.0	25.0	17.0	9.0	21.0
0.0027	25.0	12.0	7.0	21.0	25.0	13.0	8.0	21.0	25.0	16.0	8.5	21.0	25.0	18.0	10.0	21.0
0.0033	25.0	12.5	7.5	21.0	25.0	15.0	8.5	21.0	25.0	17.0	9.5	21.0	25.0	20.0	10.5	21.0
0.0039	25.0	13.0	8.0	21.0	25.0	16.0	9.5	21.0	25.0	18.5	10.0	21.0	25.0	21.0	11.0	21.0
0.0047	25.0	13.5	8.5	21.0	25.0	17.0	10.5	21.0	25.0	20.0	10.5	21.0	31.0	20.0	10.5	27.5
0.0056	25.0	16.0	9.5	21.0	25.0	18.0	11.5	21.0	31.0	20.0	10.0	27.5	31.0	21.0	11.5	27.5
0.0068	25.0	16.5	10.5	21.0	31.0	17.0	10.5	27.5	31.0	21.0	10.5	27.5	31.0	20.0	12.0	27.5
0.0082	25.0	17.5	11.5	21.0	31.0	18.0	11.0	27.5	31.0	22.0	11.0	27.5	31.0	23.0	13.0	27.5
0.01	25.0	19.5	12.0	21.0	31.0	21.0	12.0	27.5	31.0	23.0	12.0	27.5	31.0	24.0	14.0	27.5
0.012	25.0	21.0	13.5	21.0	31.0	22.0	13.0	27.5	31.0	24.0	13.5	27.5	31.0	25.5	15.5	27.5
0.015	31.0	20.0	12.0	27.5	31.0	23.0	14.0	27.5	31.0	26.0	16.0	27.5	31.0	28.0	17.0	27.5
0.018	31.0	20.5	12.5	27.5	31.0	25.0	15.0	27.5	31.0	28.0	18.0	27.5				
0.022	31.0	24.5	14.0	27.5	31.0	28.0	16.5	27.5	31.0	30.0	20.0	27.5				
0.027	31.0	25.5	15.5	27.5	31.0	30.0	18.5	27.5								
0.033	31.0	27.5	17.5	27.5	31.0	32.0	21.0	27.5								