

Taping Specification

Bandolier for axial leads

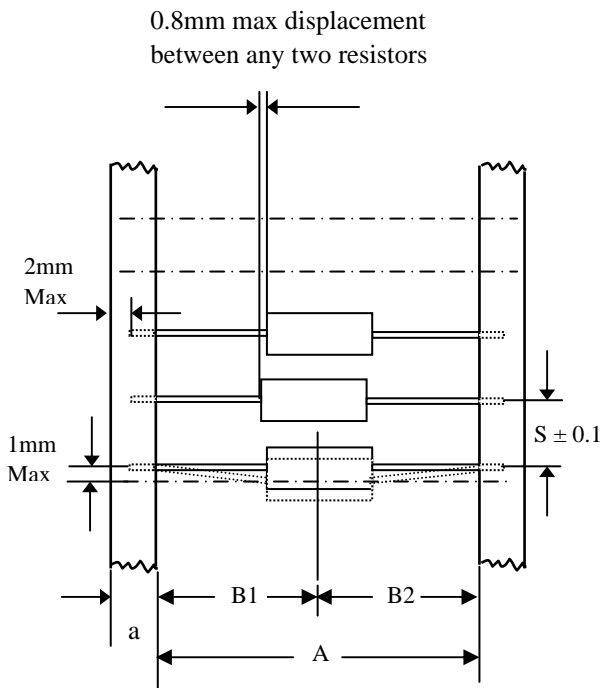

Dimension (mm)

WATT	a ± 0.5	A ± 1.5	B1-B2 ±MAX	S (spacing)
1/8W, 1/4WS	6	52.5*	1.2	5
		26.0	1.0	
1/4W, 1/2WS	6	52.5*	1.2	5
		26.0	1.0	
1/2W, 1WS	6	52.5	1.2	5
1W, 2WS	6	52.5	1.2	5
		73.0*	1.5	
2W, 3WS	6	52.5	1.2	10
		73.0*	1.5	
3W,5WS	6	52.5	1.2	10
		73.0*	1.5	
5W	6	88.0	2.0	10

* means standard taping range

Max deviation of spacing: 1mm per 10 spacing, 0.5mm per 5 spacing

Resistors Specification

TAPE IN REEL RACKING

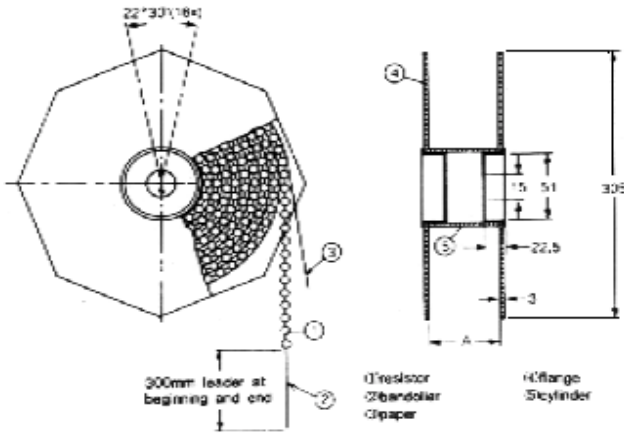

DIMENSION (mm)

WATT	ACROSS FLANGE(A)	QUANTITY PER REEL
1/8 W	72	5,000
1/4 W	48,72	5,000
1/2 W	72	2,500
1 W	72,95	2,000
2 W	72,95	1,000

TAPE ON BOX RACKING

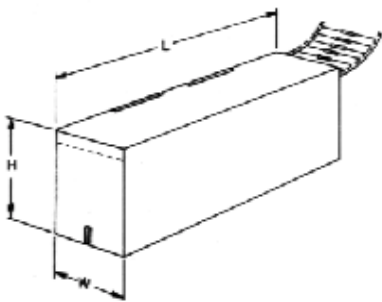

DIMENSION (mm)

WATT	W.	H.	L.	QUANTITY PER BOX
1/8W	42,75	68	255	5,000
1/4W	74	23	263	1,000
	42,85	100	263	5,000
1/2W	74	46	258	1,000
1W	85,103	95	263	1,000
2W	85,103	95	263	1,000

BULK IN BOX RACKING

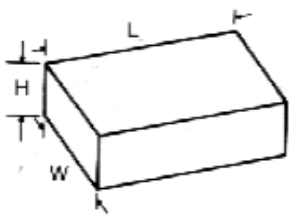

DIMENSION (mm)

WATT	W.	H.	L.	Q'TY PER BOX	Q'TY PER POLY BAG
1/8W	75	30	75	1000	500
1/4W	75	30	150	1000	200/500
1/2W	75	65	150	1000	100/200
1W	130	85	150	1000	100
2W	130	85	150	1000	100

HITANO ENTERPRISE CORP.

7F-7, NO. 3, Wu Chuan 1st Rd., Wu Ku Industrial Park, Taipei Hsien, Taiwan

Tel:(886)-2-2299 1331 Fax:(886)-2-2298 2466

E-mail : info@hitano.com.tw