



HITANO ENTERPRISE CORP.

7F-7, No. 3, Wu Chuan 1st Road, New Taipei
 Industrial Park, New Taipei City, TAIWAN, R.O.C.
 Tel: +886 2 2299 1331 Fax: +886 2 2298 2466

Data Sheet

Customer: _____

Product : Automotive Grade High Voltage Thin Film Flat Chip Resistor
 - HARHV Series

Size: 0805 /1206 /1210

Issued Date: 13-Feb-23

Edition : REV. A2

Record of change

Date	Ver.	Description	Page

VENDOR :

HITANO ENTERPRISE CORP.
 7F-7,NO.3,WUCHUAN1ST ROAD,
 NEW TAIPEI INDUSTRIAL PARK,
 NEW TAIPEI CITY, TAIWAN, R.O.C.
 TEL:+886222991331(REP.)
 FAX:+886222982466



MAKER :

VIKING TECH CORPORATION
 No.70, Guangfu N. Rad., Hsin Chu Industrial Park,
 Hukou Hsiang, Hsin Chu Hsien, 303, Taiwan
 TEL:886-3-5972931
 FAX:886-3-5972935•886-3-5973494





■ **Features**

- High operating voltage U_{max} . up to 1000 V
- Low voltage coefficient <math><1.5 \text{ ppm/V}</math>
- Superior moisture resistivity (85°C;85% RH)
- AEC-Q200 Compliance
- Test proven immunity to humidity, moisture, and sulfur

■ **Applications**

- Industrial and automotive inverters
- Battery management system
- Testing / Measurement Equipment
- Automatic Equipment Controller

■ **Construction**

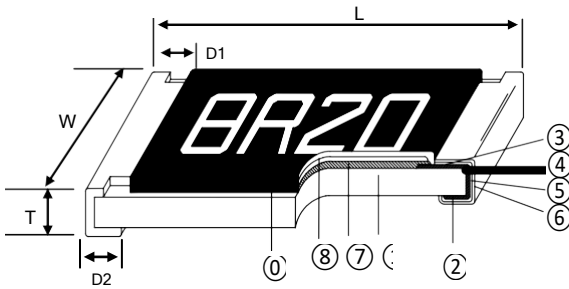

① Alumina Substrate	④ Edge Electrode	⑦ Resistor Layer
② Bottom Electrode	⑤ Barrier Layer	⑧ Overcoat
③ Top Electrode	⑥ External Electrode	⑩ Marking

■ **Dimensions**

Unit: mm

Type	Size (Inch)	L	W	T	D1	D2	Weight (g) (1000pcs)
HARHV05	0805	2.00±0.15	1.25±0.15	0.55±0.10	0.30±0.20	0.40±0.25	5.3
HARHV06	1206	3.05±0.15	1.55±0.15	0.55±0.10	0.42±0.20	0.35±0.25	10.8
HARHV13	1210	3.10±0.15	2.40±0.15	0.55±0.10	0.40±0.20	0.55±0.25	15.7

■ **Part Numbering**

HARHV	13	B	T	C		1001	A
Product Type	Dimensions (L×W) 05:0805 06:1206 13:1210	Resistance Tolerance B: ±0.1% C: ±0.25% D: ±0.5% F: ±1%	Packaging Code T: Taping Reel B: Bulk	TCR (PPM/°C) C: ±25 D: ±50	Power Rating :Standard	Resistance 0100: 10Ω 10R2: 10.2Ω 1000: 100Ω 1001: 1KΩ 1004: 1MΩ	Marking Code A: Automotive Grade NA: No Marking Automotive Grade

**** If you have any request not find from above datas, please contact our sales for further information, we may do our best to meet your request.**

■ Derating Curve

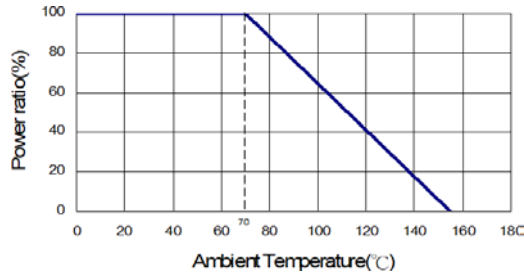

■ Standard Electrical Specifications

Item Type	Power Rating at 70°C	Operating Temp. Range	Max. Operating Voltage	Max. Overload Voltage	Resistance Range				TCR (PPM/°C)
					±0.1%	±0.25%	±0.5%	±1%	
HARHV05 (0805)	1/5W	-55 ~ +155°C	450V	900V	180K~1MΩ				±25 ±50
HARHV06 (1206)	1/4W	-55 ~ +155°C	700V	1400V	160K~2MΩ				±25 ±50
HARHV13 (1210)	1/3W	-55 ~ +155°C	1000V	2000V	121K~3.01MΩ				±25 ±50

■ Environmental Characteristics

Item	Requirement	Test Method
Temperature Coefficient of Resistance (T.C.R.)	As Spec.	JIS-C-5201-1 4.8 IEC-60115-1 4.8 -55°C~+125°C, 25°C is the reference temperature
Short Time Overload	$\Delta R \pm 0.05\%$	JIS-C-5201-1 4.13 $U = 2 * \sqrt{P * R}$ or Max. overload voltage whichever is lower for 5 seconds
Endurance	$\Delta R \pm 0.1\%$	MIL-STD-202 Method 108 $U = \sqrt{P * R}$ 1.5 h on; 0.5 h off; 70 °C; 1000 h
Damp Heat with Load	$\Delta R \pm 0.1\%$	MIL-STD-202 Method 103 $U = 0.1 * \sqrt{P * R}$ 40±2°C, 90~95% R.H. 1000 hrs with 1.5 hrs "ON" and 0.5 hrs "OFF"
Biased Humidity	$\Delta R \pm 0.25\%$	MIL-STD-202 Method 103 $U = 0.3 * \sqrt{P * R}$ 1000 hrs 85°C/85%RH Voltage isn't exceeding 100V
Temperature Cycling	$\Delta R \pm 0.1\%$	JESD22 Method JA-104 -55°C to +125°C, 1000 cycles

High Temperature Exposure	$\Delta R \pm 0.2\%$	MIL-STD-202 Method 108 at +155°C for 1000 hrs
Single pulse high voltage overload	$\Delta R \pm 0.1\%$	IEC61000-4-5 $U = 2 \times \sqrt{(P \cdot R)}$ 10pulses 10us / 700us
Periodic electric overload	$\Delta R \pm 0.1\%$	IEC 60115- 4.39 $U = 2 \times \sqrt{(P \cdot R)}$ 0.1 s on; 2.5 s off; 1000 cycles
Bending Strength (Board Flex)	$\Delta R \pm 0.05\%$	JIS-C-5201-1 4.33 Bending amplitude 3mm for 60 seconds
Solderability	95% min. coverage	JIS-C-5201-1 4.17 IEC-60115-1 4.17 245±5°C for 3 seconds
Resistance to Soldering Heat	$\Delta R \pm 0.02\%$	JIS-C-5201-1 4.18 IEC-60115-1 4.18 260±5°C for 10 seconds
Terminal strength	No broken	AEC-Q200-006 Force of 1.8 kg for 60 seconds.
Vibration	$\Delta R \pm 0.05\%$	MIL-STD-202 Method 204 5g's for 20min, 12 cycles each of 3 orientations, 10-2000Hz
ESD	$\Delta R \pm 0.5\%$	AEC-Q200-002 Human body model 0805 : 2KV 1206.1210 : 6KV
Resistance to solvents	Marking Unsmearred	MIL-STD-202 Method 215 Add Aqueous wash chemical - OKEM Clean or equivalent. Do not use banned solvents.
Flammability	No ignition of the tissue paper or scorching or the pinewood board	UL-94 V-0 or V-1 are acceptable. Electrical test not required.
Sulfur Test	$\Delta R \pm 1\%$	ASTM-B-809-95 Modified 105±2 °C no power rating for 750 hrs.

RCWV(Rated continuous working voltage)= $\sqrt{(P \cdot R)}$ or Max. Operating voltage whichever is lower

- Storage Temperature: 15~28°C; Humidity < 80%RH
- Shelf Life: 2 years from production date.

■ Soldering Condition(IPC/JEDEC J-STD-020)

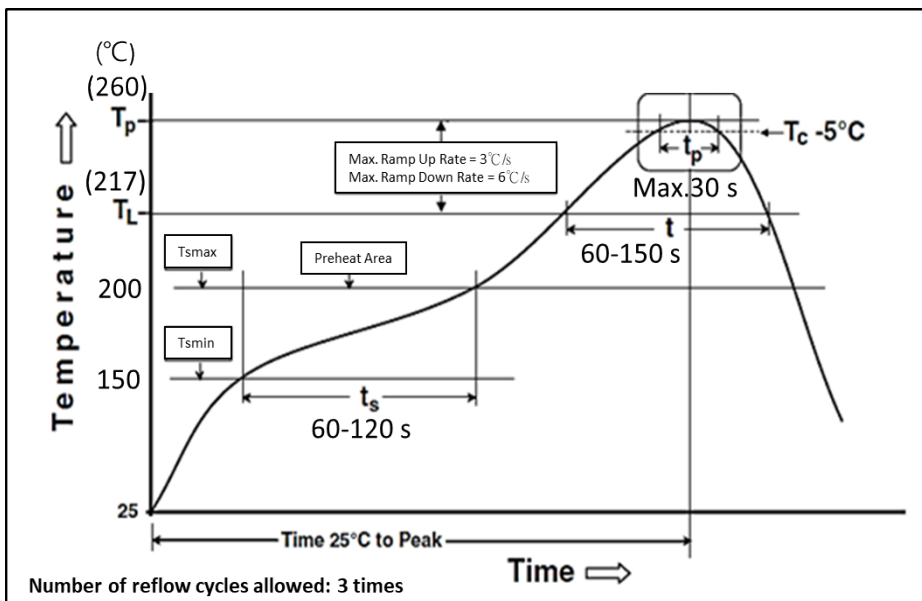

Reflow Profiles	
Profile Feature	Pb-Free Assembly
Preheat Min. Temperature (T_{smin}) Max Temperature (T_{smax}) Preheating time (t_s) from (T_{smin} to T_{smax})	150 °C 200 °C 60-120 seconds
Ramp-up rate (T_L to T_p)	3 °C/second max.
Liquidous temperature (T_L) Time (t_L) maintained above T_L	217 °C 60-150 seconds
Min. Peak temperature (T_p min)	235°C
Max. Peak temperature (T_p max)	260°C
Time (t_p) within 5 °C of the specified classification temperature (T_c)	30 seconds max.
Ramp-down rate (T_p to T_L)	6 °C/second max.
Time 25 °C to peak temperature	8 minutes max.

Marking

0805/1206/1210 4digit marking

Example

Resistance	100Ω	2.2KΩ	10KΩ	49.9KΩ	100KΩ
marking	1000	2201	1002	4992	1003

Packaging

Packing Quantity & Reel Specifications

Unit :mm

Type	∅A	∅B	∅C	W	T	Paper Tape (EA)	Emboss Plastic Tape (EA)
HARHV05	178.0±1.0	60.0±1.0	13.5±0.7	9.5±1.0	11.5±1.0	5,000	-
HARHV06	178.0±1.0	60.0±1.0	13.5±0.7	9.5±1.0	11.5±1.0	5,000	-
HARHV13	178.0±1.0	60.0±1.0	13.5±0.7	9.5±1.0	11.5±1.0	5,000	-

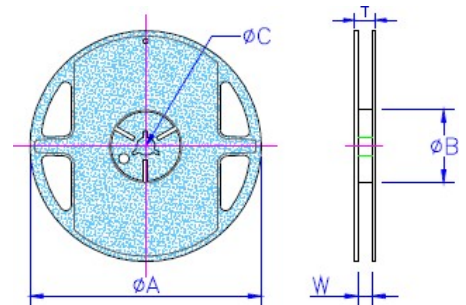

Paper Tape Specifications

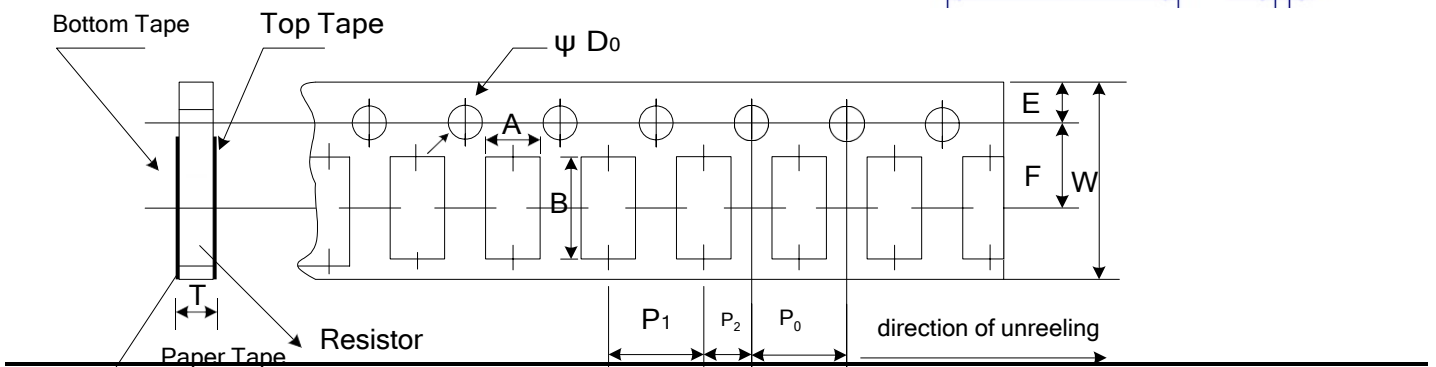

Unit: mm

Type	A	B	W	E	F	P ₀	P ₁	P ₂	ΦD ₀	T
HARHV05	1.60±0.05	2.37±0.05	8.00±0.10	1.75±0.05	3.5±0.05	4.00±0.05	4.00±0.10	2.00±0.05	1.55±0.05	0.75±0.05
HARHV06	2.00±0.05	3.55±0.05	8.00±0.10	1.75±0.05	3.5±0.05	4.00±0.05	4.00±0.10	2.00±0.05	1.55±0.05	0.75±0.05
HARHV13	2.75±0.05	3.40±0.05	8.00±0.10	1.75±0.05	3.5±0.05	4.00±0.05	4.00±0.10	2.00±0.05	1.60±0.10	0.75±0.05

- Peel force of top cover tape
- The peel speed shall be about 300mm/min±5%
- The peel force of top cover tape shall be between 8gf to 60gf

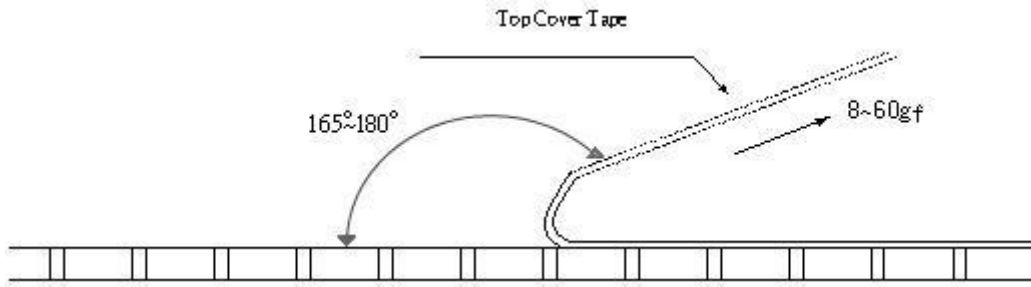

■ Recommend Land Pattern

Unit: mm

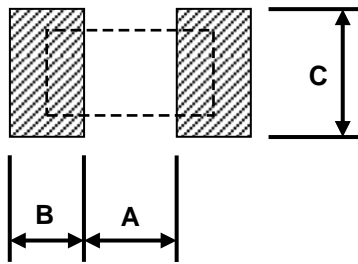

Type	A	B	C
HARHV05	1.00	1.00	1.35±0.2
HARHV06	2.00	1.15	1.70±0.2
HARHV13	2.00	1.15	2.50±0.2