



HITANO ENTERPRISE CORP.

7F-7, No. 3, Wu Chuan 1st Road, New Taipei
 Industrial Park, New Taipei City, TAIWAN, R.O.C.
 Tel: +886 2 2299 1331 Fax: +886 2 2298 2466

Data Sheet

Customer: _____

Product : Automotive Grade Pulse Withstanding Chip Resistor
 – HPWR Series

Size: 0402/0603/0805/1206/1210/2010/2512

Issued Date: 31-Jan-23

Edition : REV.A4

Record of change

Date	Ver.	Description	Page

VENDOR :

HITANO ENTERPRISE CORP.

7F-7,NO.3,WUCHUAN1ST ROAD,
 NEW TAIPEI INDUSTRIAL PARK,
 NEW TAIPEI CITY, TAIWAN, R.O.C.
 TEL:+886222991331(REP.)
 FAX:+886222982466



MAKER :

VIKING TECH CORPORATION

No.70, Guangfu N. Rad., Hsin Chu Industrial Park,
 Hukou Hsiang, Hsin Chu Hsien, 303, Taiwan
 TEL:886-3-5972931
 FAX:886-3-5972935•886-3-5973494



HPWR series.

Automotive Grade Pulse Withstanding Chip Resistor



■ Features

- Tolerance from $\pm 0.5\%$ ~ 5%
- High power rating
- Excellent pulse withstanding performance
- Improved working voltage ratings
- Standard package sizes of 0402~2512
- Special construction to prevent sulfuration in a sulfur containing environment
- AEC-Q200 Compliance
- 100% CCD inspection

■ Applications

- Metering (Testing/Measurement)
- Diagnostic Equipment
- Medical Devices
- Industrial Controls
- Plasma
- LCD Video Monitors

■ Construction

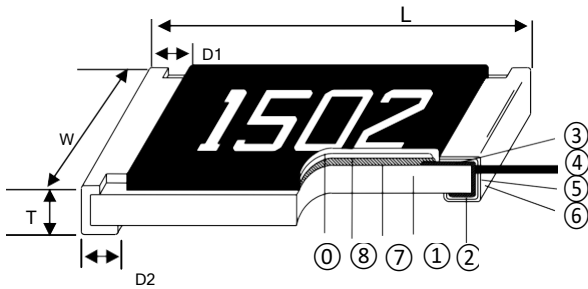

① Alumina Substrate	⑥ External Electrode
② Bottom Electrode	⑦ Resistor Layer
③ Top Electrode	⑧ Primary Overcoat
④ Edge Electrode	⑩ Secondary Overcoat
⑤ Barrier Layer	

■ Dimensions

Type	Size (Inch)	L (mm)	W (mm)	T (mm)	D1 (mm)	D2 (mm)	Weight (g) (1000pcs)
HPWR02	0402	1.00 \pm 0.05	0.50 \pm 0.05	0.35 \pm 0.05	0.20 \pm 0.10	0.20 \pm 0.10	0.63
HPWR03	0603	1.60 \pm 0.10	0.80 \pm 0.10	0.45 \pm 0.10	0.30 \pm 0.20	0.30 \pm 0.20	2.042
HPWR05	0805	2.00 \pm 0.10	1.25 \pm 0.10	0.50 \pm 0.10	0.35 \pm 0.20	0.40 \pm 0.20	4.368
HPWR05(1/2W)	0805	2.00 \pm 0.10	1.25 \pm 0.10	0.55 \pm 0.10	0.35 \pm 0.20	0.40 \pm 0.20	5
HPWR06	1206	3.10 \pm 0.10	1.55 \pm 0.10	0.55 \pm 0.10	0.50 \pm 0.25	0.50 \pm 0.20	8.947
HPWR06(3/4W)	1206	3.10 \pm 0.10	1.55 \pm 0.10	0.55 \pm 0.10	0.60 \pm 0.25	0.55 \pm 0.25	9.2
HPWR13	1210	3.10 \pm 0.10	2.60 \pm 0.15	0.55 \pm 0.10	0.50 \pm 0.25	0.50 \pm 0.20	15.959
HPWR10	2010	5.00 \pm 0.10	2.50 \pm 0.15	0.55 \pm 0.10	0.60 \pm 0.25	0.50 \pm 0.20	24.241
HPWR12	2512	6.35 \pm 0.10	3.10 \pm 0.15	0.55 \pm 0.10	0.60 \pm 0.25	0.50 \pm 0.20	39.448
HPWR12 (2W)	2512	6.35 \pm 0.20	3.15 \pm 0.15	0.60 \pm 0.10	0.80 \pm 0.25	0.60 \pm 0.30	42

**** If you have any request not find from above datas, please contact our sales for further information, we may do our best to meet your request.**

■ Derating Curve

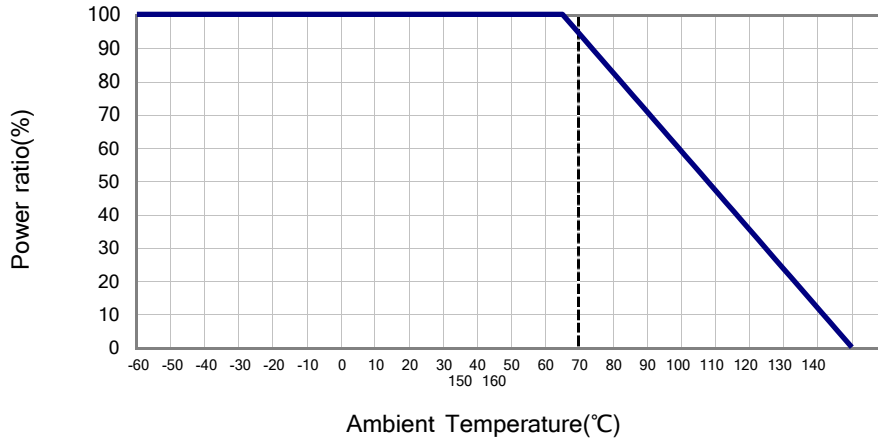

■ Part Numbering

HPWR	12	J	T	E	S	1001	A
Product Type	Dimensions	Resistance Tolerance	Packaging Code	TCR (PPM/°C)	Power Rating	Resistance	Marking
	02: 0402 03: 0603 05: 0805 06: 1206 13: 1210 10: 2010 12: 2512	D: ±0.5% F: ±1% J: ±5% -: No specified	T: 7" Taping Reel V: 10" Taping Reel W: 13" Taping Reel	E: ±100 F: ±200 G: ±300 4: ±350 -: No specified	A: 1.5W T: 1W Q: 3/4W U: 1/2W G: 2/5W O: 1/3W V: 1/4W W: 1/8W X: 1/10W P: 1/5W S: 2W K: 1.25W	1001: 1KΩ 1004: 1MΩ R0R0: 0Ω	A: Automotive Grade NA: Automotive Grade & No Marking

■ Standard Electrical Specifications

Item Type	Power Rating at 70°C	Operating Temp. Range	Max. Operating Voltage	Max. Overload Voltage	Resistance Range			TCR (PPM/°C)
					±0.5% (E24,E96)	±1% (E24,E96)	±5% (E24)	
HPWR02 (0402)	1/5W	-55 ~ +155°C	50V	100V	-	1Ω-20Ω		±300
					100Ω-1MΩ	20.5Ω-1MΩ		±100
HPWR03 (0603)	1/10W	-55 ~ +155°C	50V	100V	10Ω - 294Ω	1Ω - 294Ω		±200
					300Ω - 1MΩ			±100
HPWR05 (0805)	1/8W	-55 ~ +155°C	150V	300V	10Ω - 294Ω	1Ω - 294Ω		±200
					300Ω - 20MΩ			±100
HPWR06 (1206)	1/3W	-55 ~ +155°C	200V	400V	10Ω - 20Ω	1Ω - 20Ω		±200
					20.5Ω - 20MΩ			±100
HPWR13 (1210)	1/2W	-55 ~ +155°C	200V	400V	10Ω - 20Ω	1Ω - 20Ω		±200
					20.5Ω - 20MΩ			±100
HPWR10 (2010)	3/4W	-55 ~ +155°C	400V	800V	10Ω - 20Ω	1Ω - 20Ω		±200
					20.5Ω - 20MΩ			±100
HPWR12 (2512)	1.5W	-55 ~ +155°C	500V	1000V	10Ω - 20Ω	1Ω - 20Ω		±200
					20.5Ω - 20MΩ			±100

■ High Power & Ultra High Power Rating Electrical Specifications

Item Type	Power Rating at 70°C	Operating Temp. Range	Max. Operating Voltage	Max. Overload Voltage	Resistance Range			TCR (PPM/°C)
	Jumper Rated Current				±0.5% (E24,E96)	±1% (E24,E96)	±5% (E24)	
HPWR03 (0603)	1/4W	-55 ~ +155°C	75V	150V	10Ω - 294Ω	1Ω - 294Ω		±200
	Jumper: 5A*				300Ω - 1MΩ			±100
					-	0Ω(≦8mΩ)		-
HPWR05 (0805)	2/5W	-55 ~ +155°C	150V	300V	10Ω - 294Ω	1Ω - 294Ω		±200
					300Ω - 1MΩ			±100
HPWR05 (0805)	1/2W *	-55 ~ +155°C	400V	600V	10Ω - 294Ω	1Ω - 294Ω		±200
	Jumper: 6A*				300Ω - 1MΩ			±100
					-	0Ω(≦5mΩ)		-
HPWR06 (1206)	1/2W	-55 ~ +155°C	200V	400V	10Ω - 20Ω	1Ω - 20Ω		±200
					20.5Ω - 1MΩ			±100
HPWR06 (1206)	3/4W *	-55 ~ +155°C	500V	1000V	10Ω - 20Ω	1Ω - 20Ω		±200
	Jumper: 10A*				20.5Ω - 1MΩ			±100
					-	0Ω(≦5mΩ)		-
HPWR13 (1210)	3/4W	-55 ~ +155°C	200V	400V	10Ω - 20Ω	1Ω - 20Ω		±200
					20.5Ω - 1MΩ			±100
HPWR10 (2010)	1W 1.25W	-55 ~ +155°C	400V	800V	10Ω - 20Ω	1Ω - 20Ω		±200
	20.5Ω - 1MΩ				±100			
HPWR12 (2512)	2W *	-55 ~ +155°C	500V	1000V	10Ω	1Ω - 10Ω		±350
					10.2Ω-200K			±100

*: Ultra High Power: double side printed resistor element

Operating Voltage= $\sqrt{P \cdot R}$ or Max. Operating Voltage listed above, whichever is lower.

Overload Voltage= $2.5 \cdot \sqrt{P \cdot R}$ or Max. Overload Voltage listed above, whichever is lower.

The power rating depends on the maximum temperature of the resistive element. Due to the power dissipation of the resistor, the temperature of the resistive element will rise depending on the condition of heat dissipation from PCB. The maximum power rating in application only applies if the temperature of the resistive element is not exceed 155°C.

■ Viking is capable of manufacturing the optional spec based on customer's requirement.

■ **Soldering Condition (Ref. IPC/JEDEC J-STD-020 & J-STD-002)**

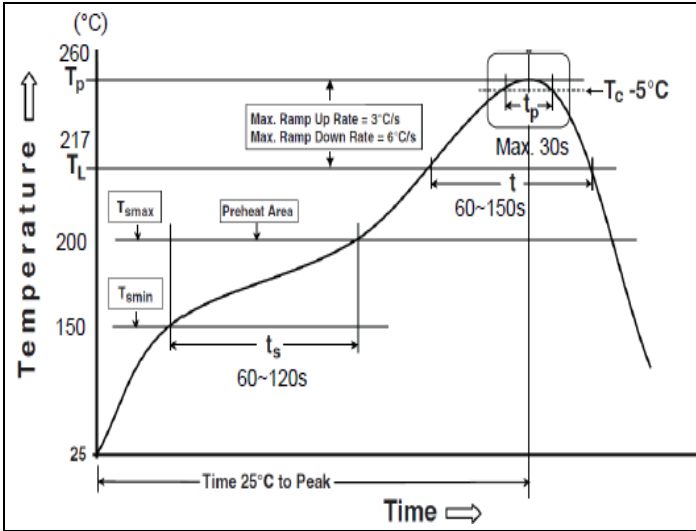

Reflow Profiles	
Profile Feature	Pb-Free Assembly
Preheat Min. Temperature (T _{min}) Max Temperature (T _{max}) Preheating time (t _s) from (T _{min} to T _{max})	150 °C 200 °C 60-120 seconds
Ramp-up rate (T _L to T _p)	3 °C/second max.
Liquidous temperature (T _L) Time (t _L) maintained above T _L	217 °C 60-150 seconds
Min. Peak temperature (T _p min)	235 °C
Max. Peak temperature (T _p max)	260 °C
Time (t _p) within 5 °C of the specified classification temperature (T _c)	30 seconds max.
Ramp-down rate (T _p to T _L)	6 °C/second max.
Time 25 °C to peak temperature	8 minutes max.

■ **Environmental Characteristics**

Item	Requirement		Test Method
	±5% and Below	Jumper	
Temperature Coefficient of Resistance (T.C.R.)	As Spec.		JIS-C-5201-1 4.8 IEC-60115-1 4.8 At 25°C/-55°C and 25°C/+125°C, 25°C is the reference temperature
Short Time Overload	±(1.0%+0.05Ω)	0603: ≦8mΩ 0805: ≦5mΩ 1206: ≦5mΩ	JIS-C-5201-1 4.13 IEC-60115-1 4.13 RCWV*2.5 or Max. Overload Voltage whichever is lower for 5 seconds Jumper: 2*I _{max} for 5 seconds
Insulation Resistance	≥10G		JIS-C-5201-1 4.6 IEC-60115-1 4.6 Max. Overload Voltage for 1 minute
Operational Life	±(1.0%+0.05Ω)	0603: ≦8mΩ 0805: ≦5mΩ 1206: ≦5mΩ	MIL-STD-202 Method 108 Condition D Steady State TA=125°C at derated power. Measurement at 24±4 hours after test conclusion.
Biased Humidity	±(1.0%+0.05Ω)	0603: ≦8mΩ 0805: ≦5mΩ 1206: ≦5mΩ	MIL-STD-202 Method 103 1000 hrs 85°C/85%RH 10% of operating power
High Temperature Exposure	±(1.0%+0.05Ω)	0603: ≦8mΩ 0805: ≦5mΩ 1206: ≦5mΩ	MIL-STD-202 Method 108 at +155°C for 1000 hrs
Board Flex	±(1.0%+0.05Ω)	0603: ≦8mΩ 0805: ≦5mΩ 1206: ≦5mΩ	AEC-Q200-005 Bending once for 60 seconds 2010, 2512 sizes: 2mm Other sizes: 3mm
Solderability	95% min. coverage		JIS-C-5201-1 4.17 IEC-60115-1 4.17 245±5°C for 3 seconds
Resistance to Soldering Heat	±(0.5%+0.05Ω)	0603: ≦8mΩ 0805: ≦5mΩ 1206: ≦5mΩ	JIS-C-5201-1 4.18 IEC-60115-1 4.18 260±5°C for 10 seconds
Voltage Proof	No breakdown or flashover		JIS-C-5201-1 4.7 IEC-60115-1 4.7 1.42 times Max. Operating Voltage for 1 minute

Item	Requirement		Test Method
	±5% and Below	Jumper	
Leaching	Individual leaching area ≤5% Total leaching area ≤ 10%		JIS-C-5201-1 4.18 IEC-60068-2-58 8.2.1 260±5°C for 30 seconds
Temperature Cycling	±(0.5%+0.05Ω)	0603: ≤8mΩ 0805: ≤5mΩ 1206: ≤5mΩ	JESD22 Method JA-104 -55°C to +125°C, 1000 cycles
Mechanical Shock	±(0.25%+0.05Ω)	0603: ≤8mΩ 0805: ≤5mΩ 1206: ≤5mΩ	MIL-STD-202 Method 213 Wave Form: Tolerance for half sine shock pulse. Peak value is 100g's. Normal duration (D) is 6.
Vibration	±(0.5%+0.05Ω)	0603: ≤8mΩ 0805: ≤5mΩ 1206: ≤5mΩ	MIL-STD-202 Method 204 5 g's for 20 min., 12 cycles each of 3 orientations, 10-2000 Hz
ESD	±(3%+0.05Ω)		AEC-Q200-002 Human body model 0402/0603: 1KV 0805 and above: 2KV
Resistance to Solvents	No visible damage on appearance and marking.		MIL-STD-202 Method 215 Add Aqueous wash chemical - OKEM Clean or equivalent. Do not use banned solvents.
Terminal Strength	No broken		AEC-Q200-006 Force of 1.8kg for 60 seconds.
Flammability	No ignition of the tissue paper or scorching or the pinewood board		UL-94 V-0 or V-1 are acceptable. Electrical test not required.
Sulfur Test	ΔR±1%	0603: ≤8mΩ 0805: ≤5mΩ 1206: ≤5mΩ	EIA-977 (Condition A) 60±2°C, no power rating for 500 hrs.

RCWV(Rated Continuous Working Voltage)=√(P*R) or Max. Operating Voltage whichever is lower.

■ **Storage Temperature: 15~28°C; Humidity < 80%RH**

■ **Shelf Life: 2 years from production date.**

■ **Packaging**

Reel Specifications & Packaging Quantity

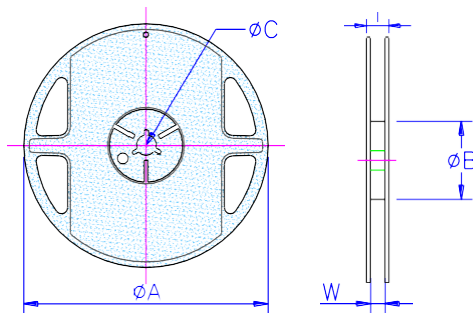

Type	Packaging Quantity	Tape Width	Reel Diameter	ΦA (mm)	ΦB (mm)	ΦC (mm)	W (mm)	T (mm)	
HPWR02	Paper	10K	8mm	7 inch	178.5±1.5	60 ^{+1/-0}	13.0±0.2	9.0±0.5	12.5±0.5
		20K	8mm	10 inch	254±1.0	100±0.5	13.0±0.2	9.5±0.5	13.5±0.5
		40K	8mm	13 inch	330±1.0	100±0.5	13.0±0.2	9.5±0.5	13.5±0.5
HPWR03 HPWR05 HPWR06 HPWR13	Paper	5K	8mm	7 inch	178.5±1.5	60 ^{+1/-0}	13.0±0.2	9.0±0.5	12.5±0.5
		10K	8mm	10 inch	254±1.0	100±0.5	13.0±0.2	9.5±0.5	13.5±0.5
		20K	8mm	13 inch	330±1.0	100±0.5	13.0±0.2	9.5±0.5	13.5±0.5
HPWR10 HPWR12	Embossed	4K	12mm	7 inch	178.5±1.5	60 ^{+1/-0}	13.0±0.5	13.0±0.5	15.5±0.5
		8K	12mm	10 inch	250±1.0	62±0.5	13.0±0.5	12.5±0.5	16.5±0.5

Paper Tape Specifications

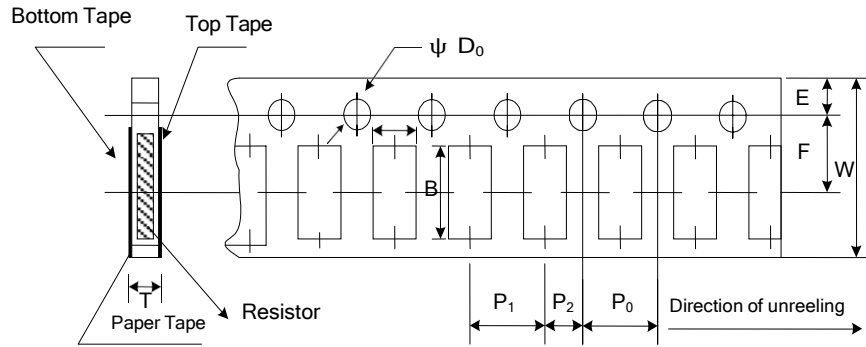

Type	A (mm)	B (mm)	W (mm)	E (mm)	F (mm)	P ₀ (mm)	P ₁ (mm)	P ₂ (mm)	ΦD ₀ (mm)	T (mm)
HPWR02	0.65±0.10	1.15±0.10	8.0±0.2	1.75±0.1	3.50±0.05	4.00±0.10	2.00±0.05	2.00±0.05	1.50+0.1,-0	0.45±0.1
HPWR03	1.10±0.10	1.90±0.1	8.0±0.2	1.75±0.1	3.50±0.05	4.00±0.10	4.00±0.05	2.00±0.05	1.50+0.1,-0	0.70±0.1
HPWR05	1.60±0.10	2.40±0.2	8.0±0.2	1.75±0.1	3.50±0.05	4.00±0.10	4.00±0.05	2.00±0.05	1.50+0.1,-0	0.85±0.1
HPWR06	1.90±0.10	3.50±0.2	8.0±0.2	1.75±0.1	3.50±0.05	4.00±0.10	4.00±0.05	2.00±0.05	1.50+0.1,-0	0.85±0.1
HPWR13	2.90±0.10	3.50±0.2	8.0±0.2	1.75±0.1	3.50±0.05	4.00±0.10	4.00±0.05	2.00±0.05	1.50+0.1,-0	0.85±0.1

Embossed Plastic Tape Specifications

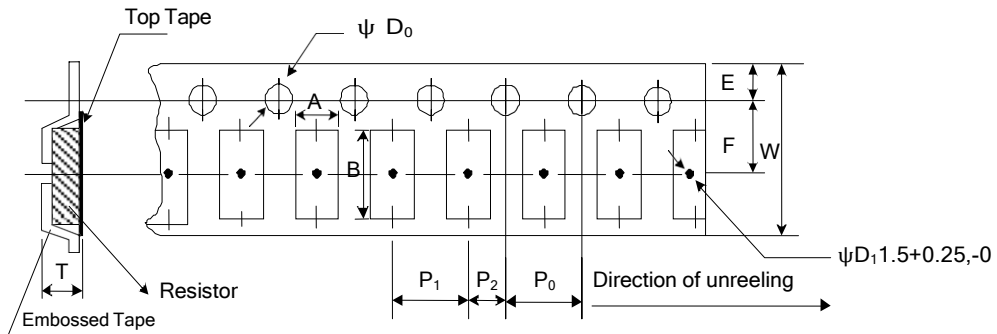

Type	A (mm)	B (mm)	W (mm)	E (mm)	F (mm)	P ₀ (mm)	P ₁ (mm)	P ₂ (mm)	ΦD ₀ (mm)	T (mm)
HPWR10	2.8±0.10	5.40±0.20	12.0±0.3	1.75±0.1	5.5±0.05	4.00±0.10	4.00±0.1	2.00±0.05	1.50+0.1, -0	1.2 ⁺⁰
HPWR12	3.5±0.10	6.70±0.10	12.0±0.3	1.75±0.1	5.5±0.05	4.00±0.10	4.00±0.1	2.00±0.05	1.50+0.1, -0	1.2 ⁺⁰

■ Recommend Land Pattern

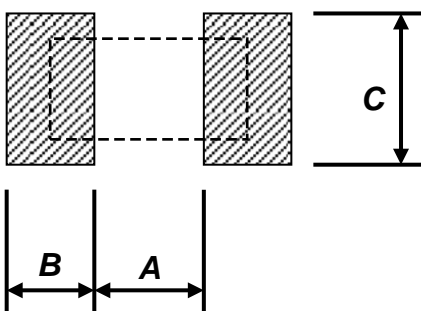

Type	A (mm)	B (mm)	C (mm)
HPWR02	0.50	0.45	0.60
HPWR03	0.90	0.60	0.90
HPWR05	1.20	0.70	1.30
HPWR06	2.00	0.90	1.60
HPWR13	2.00	0.90	2.80
HPWR10	3.80	0.90	2.80
HPWR12	4.90	1.00	3.40

■ Marking

No Marking for 0402

0805~2512 4 digits marking for Example

Resistance	5.6Ω	97.6Ω	100Ω	2.2KΩ	10KΩ	49.9KΩ	100KΩ	1MΩ
marking	5R60	97R6	1000	2201	1002	4992	1003	1004

0603: 3 digits marking in E24

Example: 101=100Ω 102=1KΩ (1st and 2nd are E24 code and 3rd code is multiplier)

E24 code	10	11	12	13	15	16	18	20	22	24	27	30	33	36	39	43	47	51	56	62	68	75	82	91
----------	----	----	----	----	----	----	----	----	----	----	----	----	----	----	----	----	----	----	----	----	----	----	----	----

1% for 0603: 3 digits marking in E96 (E96 series except E24 series)



digits marking for Example: 13C=13K3Ω 68B=4K99Ω 68X=49.9Ω

Marking Table

Code	E96	Code	E96	Code	E96	Code	E96				
02	102	28	191	52	340	75	590				
03	105	29	196	53	348	76	604				
04	107	31	205	54	357	77	619				
06	113	32	210	55	365	78	634				
07	115	33	215	56	374	79	649				
08	118	34	221	57	383	80	665				
09	121	35	226	58	392	81	681				
10	124	36	232	59	402	82	698				
11	127	37	237	60	412	83	715				
13	133	38	243	61	422	84	732				
14	137	39	249	62	432	86	768				
15	140	40	255	63	442	87	787				
16	143	41	261	64	453	88	806				
17	147	42	267	65	464	89	825				
19	154	43	274	66	475	90	845				
20	158	44	280	67	487	91	866				
21	162	45	287	68	499	92	887				
22	165	46	294	69	511	93	909				
23	169	47	301	70	523	94	931				
24	174	48	309	71	536	95	953				
25	178	49	316	72	549	96	976				
26	182	50	324	73	562						
27	187	51	332	74	576						
Code	A	B	C	D	E	F	G	X	Y		
Multiplier	10 ⁰	10 ¹	10 ²	10 ³	10 ⁴	10 ⁵	10 ⁶	10 ⁻¹	10 ⁻²		

■ **Lightning Surge**

Resistors are tested in accordance with IEC 60115-1 using both 1.2/50us and 10/700 pulse shapes. The limit of acceptance is a shift in resistance of less than 1% from the initial value.

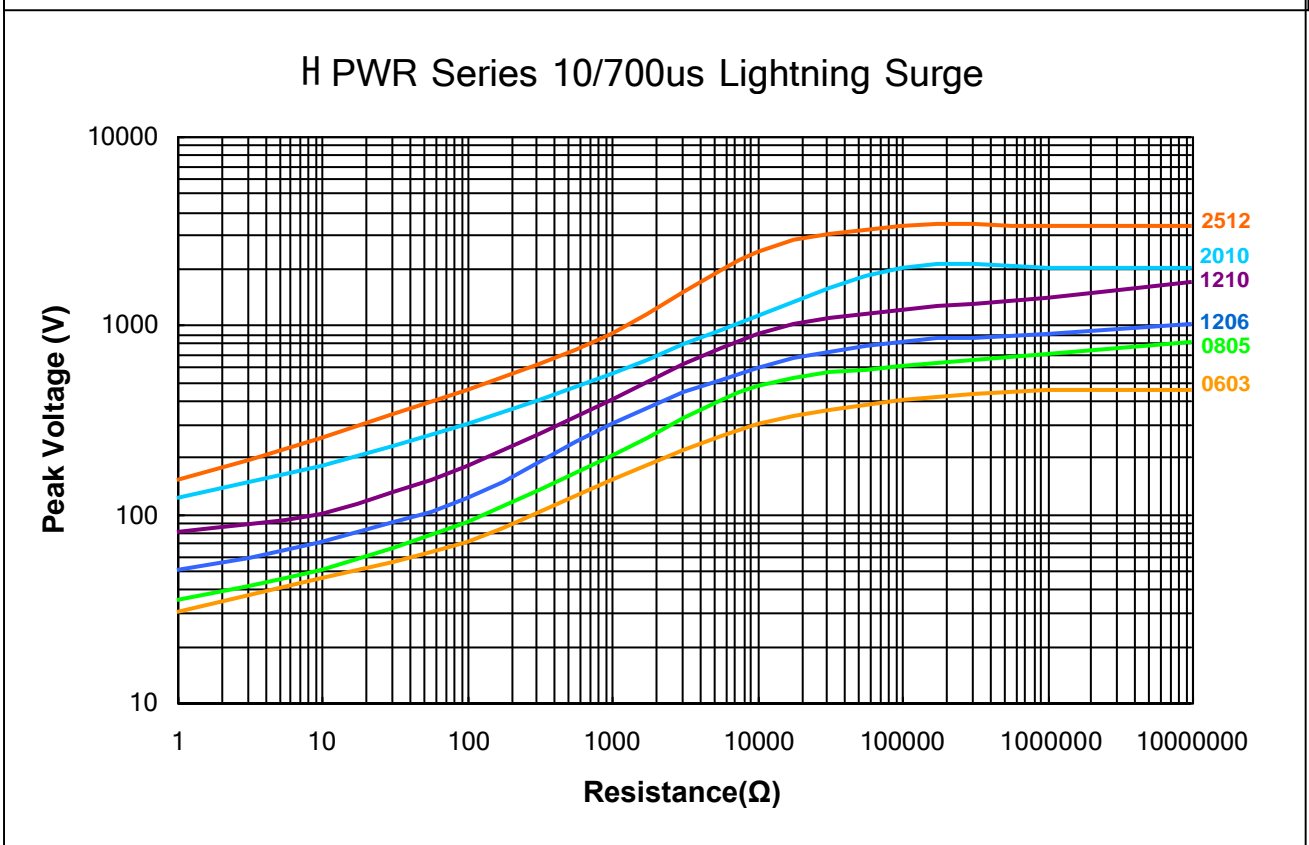
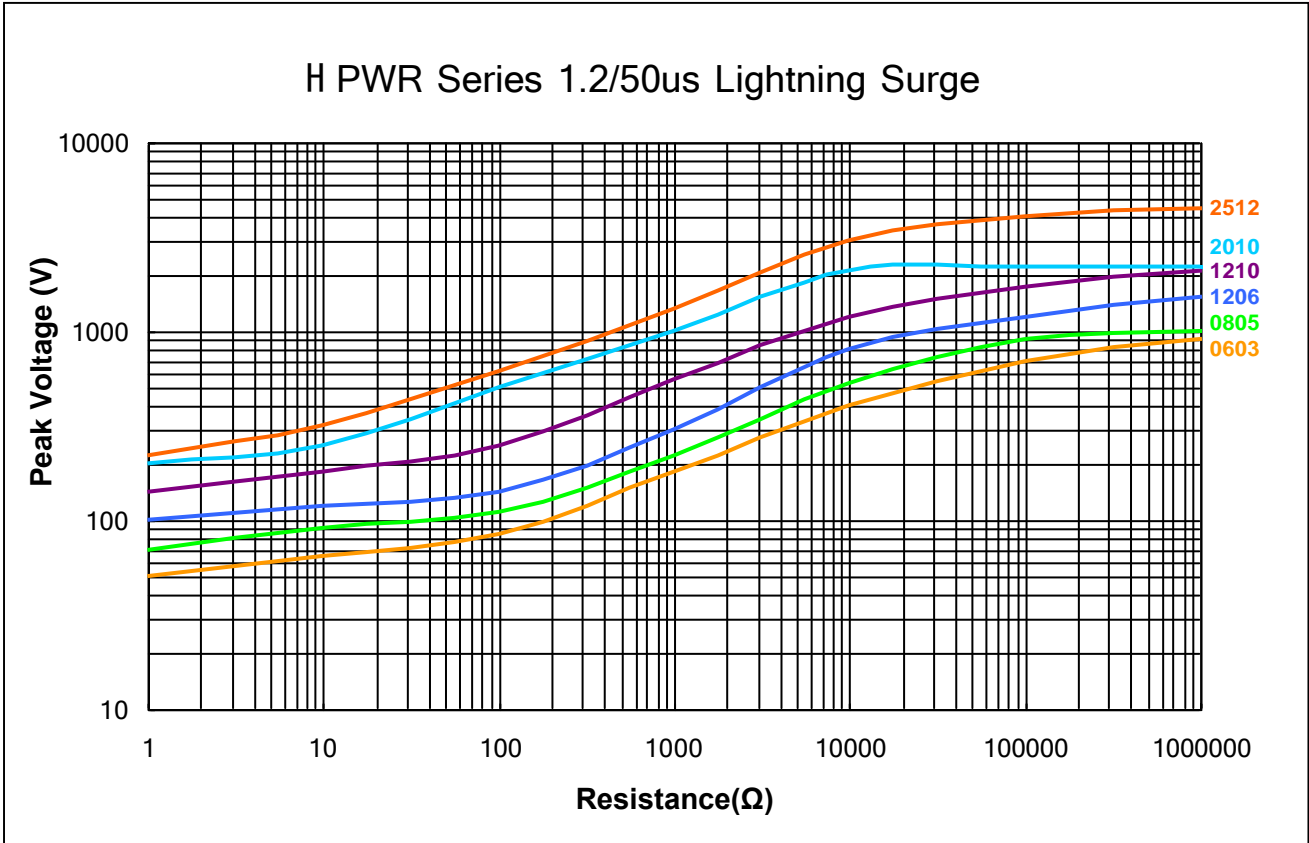

■ **Pulse withstanding capacity**

The limit of acceptance was a shift in resistance of less than 1% from the initial value. The power applied was subject to the restrictions of the maximum permissible impulse voltage graph shown.

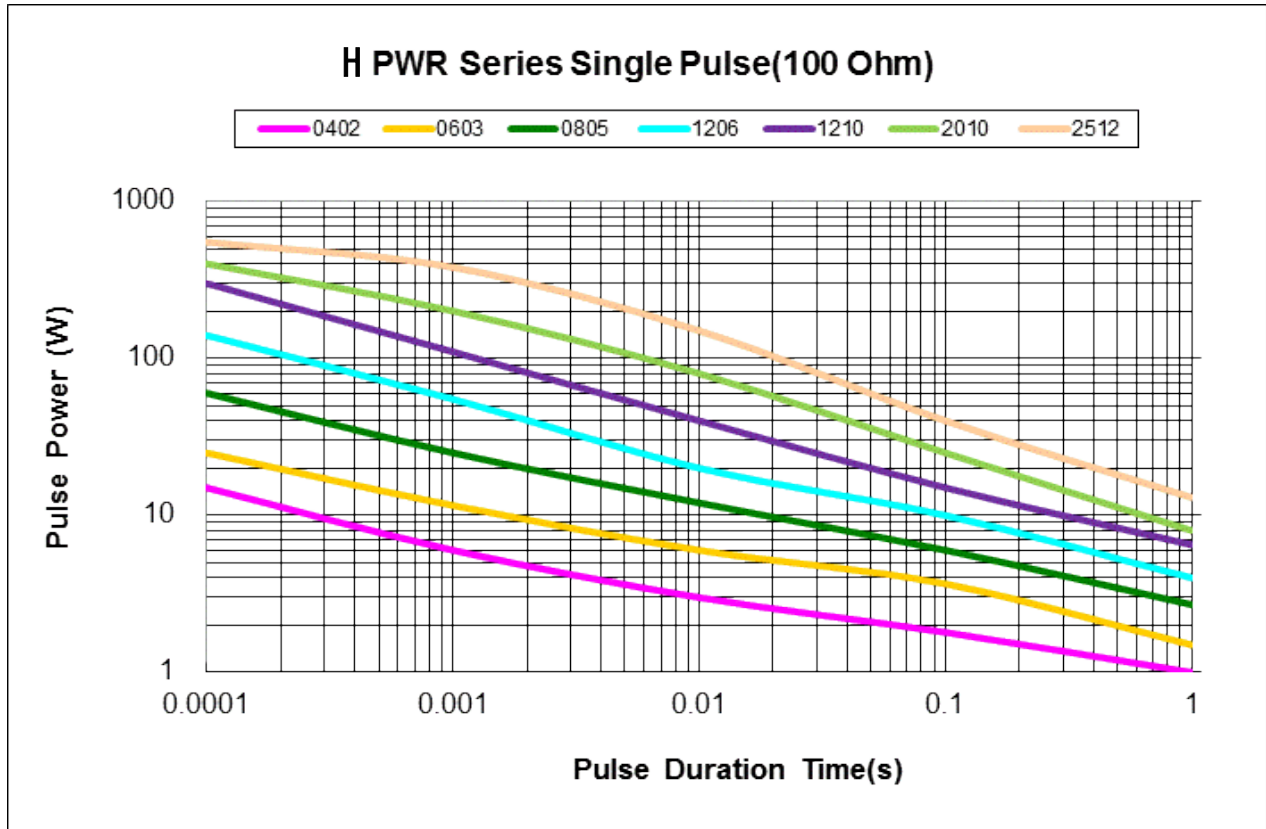

■ **Continuous Pulse**

The continuous load graph was obtained by applying repetitive rectangular pulses where the pulse period was adjusted so that the average power dissipated in the resistor was equal to its rated power at 70°C. Again the limit of acceptance was a shift in resistance of less than 1% from the initial value.

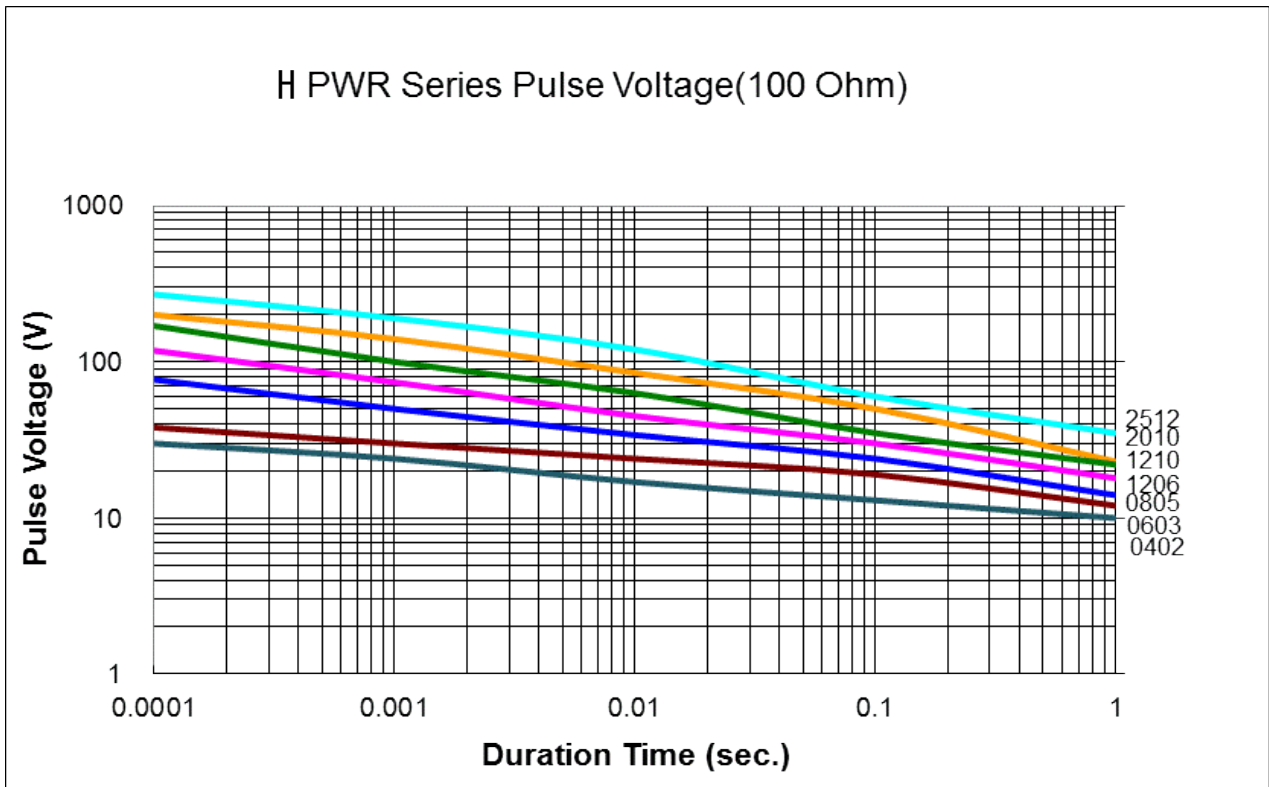
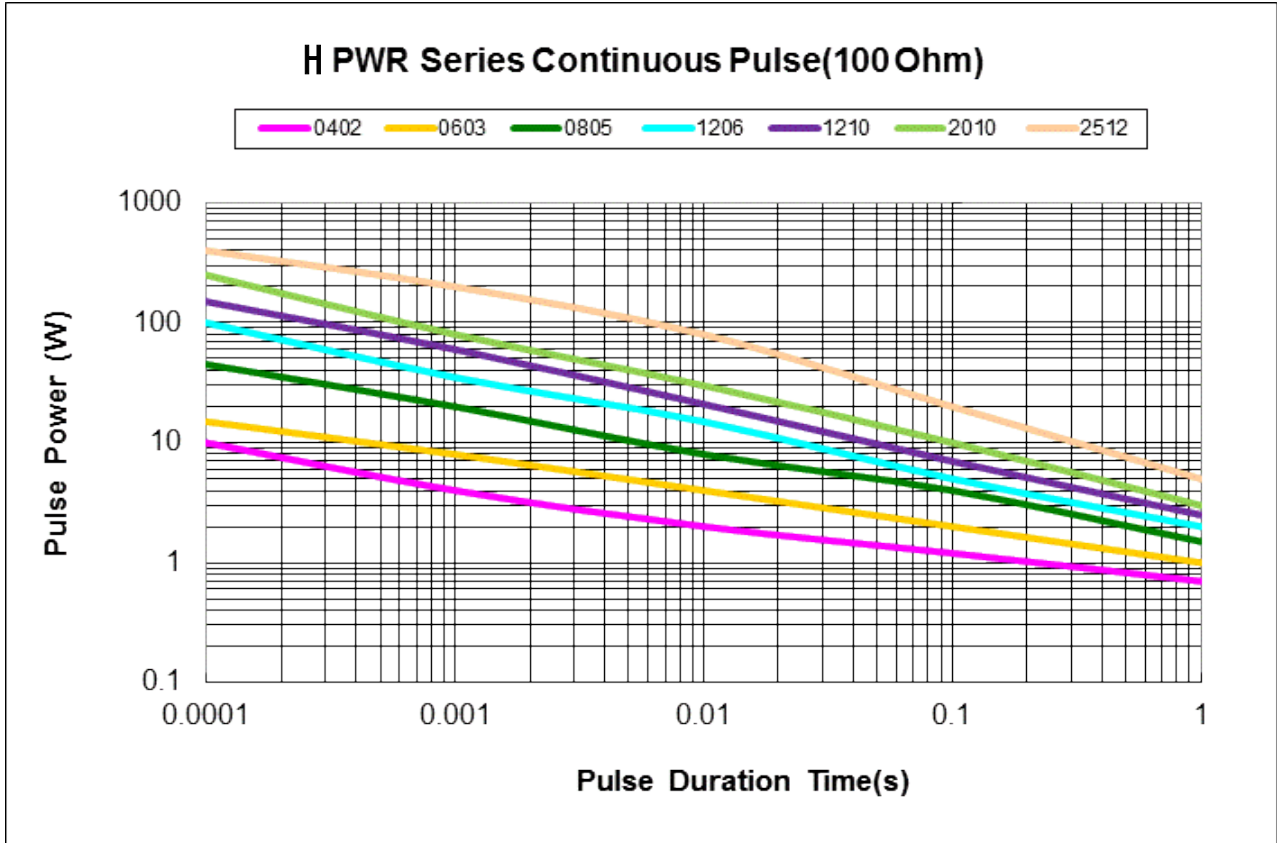



HPWR series.

Automotive Grade Pulse Withstanding Chip Resistor

REVISION HISTORY

REVISION	DATE	CHANGE NOTIFICATION	DESCRIPTION
Version A	Mar 10, 2021	-	- New product release
Version A1	Nov 15, 2021	-	- Increase the shelf life description
Version A2	Feb 15, 2022	-	- Derating Curve changes the temperature range
Version A3	Jun 15, 2022	-	- Modify Soldering Condition
Version A4	Jan 31, 2023	-	- Increase 2010 1.25W