

Data Sheet

Customer: _____

Product: Automotive Soft Termination Multilayer Ceramic Chip Capacitors

Part No. _____

Part Description : _____

Issued Date: 28-Sep.-2023

Edition: Ver. 1

Record of change

Date	Ver.	Description	Page

VENDOR :

HITANO ENTERPRISE CORP.

7F-7,NO.3,WUCHUAN1ST ROAD,
 NEW TAIPEI INDUSTRIAL PARK,
 NEW TAIPEI CITY, TAIWAN, R.O.C.
 TEL: +886222991331(REP.)
 FAX: +886222982466



MAKER :

Prosperity Dielectric Co., Ltd.

No.220-1, Sec. 2, Nanshan Rd., Lujhu, Taoyuan
 33860, Taiwan, R.O.C



1. INTRODUCTION

MLCC consists of a conducting material and electrodes. To manufacture a chip-type SMT and achieve miniaturization, high density and high efficiency, ceramic condensers are used.

HSMT Soft termination series MLCC is made by X7R/X7S/C0G(NPO) dielectrics and which provides product with high electrical precision, stability and reliability. Besides, HSMT Soft termination series MLCC is tighten controlling in quality in line to assure quality performance in automotive applications and qualified to AEC-Q200.

2. FEATURES

- A wide selection of sizes is available (0603 to 1812).
- High capacitance in given case size.
- Capacitor with lead-free termination (pure Tin).
- The HSMT Soft termination series meet AEC-Q200 requirement.
- RoHS Compliant.

3. APPLICATIONS

- For Navigation & Information equipments.
- For entertainment equipments.
- For comfortable equipments.
- For Automotive electronic equipment.

4. HOW TO ORDER

<u>HSMT</u>	<u>32</u>	<u>X</u>	<u>106</u>	<u>J</u>	<u>250</u>	<u>E</u>	<u>G</u>	<u>E</u>
Series	Size	Dielectric	Capacitance	Tolerance	Rated Voltage	Packaging	Thickness	Control Code
Table 1	Table 2	Table 3	Table 4	Table 5	Table 6	Table 7	Table 8	Table 9

Table 1		Series			
Code	Description				
HSMT	Automotive Capacitor Qualified to AEC-Q200				

Table 2		Size			
Code	Description	Code	Description	Code	Description
15	0402(1005)	31	1206(3216)	43	1812(4532)
18	0603(1608)	32	1210(3225)	55	2220 (5750)
21	0805(2012)	42	1808(4520)		

Table 3		Dielectric Material Characteristics	
Code	Description	Code	Description
X	X7R	A	X7S
N	C0G(NPO)		

Table 4		Capacitance Rule Code	
Code	Description	Code	Description
R47	0.47pF	102	102=10x10 ² =1000pF
0R5	0.5pF	104	104=10x10 ⁴ =100nF
100	100=10x10 ⁰ =10pF	106	106=10x10 ⁶ =10μF

Table 5		Tolerance			
Code	Description	Code	Description	Code	Description
A	±0.05 pF	I	-10% ~ 0%	Q	±0.03 pF
B	±0.10 pF	J	±5 %	Z	-20% ~ +80%
C	±0.25 pF	K	±10 %	X	+10%~+20%
D	±0.50 pF	L	0% ~ +10%		
F	±1 %	M	±20 %		
G	±2 %	N	-5% ~ +10%		
H	±3 %	P	±0.02 pF		

Table 6		Rated Voltage			
Code	Description	Code	Description	Code	Description
100	10Vdc	500	50Vdc	631	630Vdc
160	16Vdc	101	100Vdc	102	1000Vdc
250	25Vdc	251	250Vdc	202	2000Vdc

Table 7		Packaging Type	
Code	Description	Code	Description
B	Bulk	T	Tray package
E	Tape and 7" Reel, Embossed Tape	P	Tape and 7" Reel, Paper Tape
K	Tape and 10" Reel, Embossed Tape	D	Tape and 10" Reel, Paper Tape
L	Tape and 13" Reel, Embossed Tape	G	Tape and 13" Reel, Paper Tape

Table 8		Thickness Description			
Code	Description	Code	Description	Code	Description
A	0.60 ± 0.10 mm	I	1.25 ± 0.20 mm	Q	0.50+0.02/-0.05 mm
B	0.8 + 0.15/-0.10 mm	J	1.15 ± 0.15 mm	R	3.10 ± 0.30 mm
C	1.25 ± 0.10 mm	K	0.50 ± 0.20 mm	S	0.80 ± 0.07 mm
D	1.40 ± 0.15 mm	L	0.30 ± 0.03 mm	T	0.85 ± 0.10 mm
E	1.60 ± 0.20 mm	M	0.95 ± 0.10 mm	U	0.50 ± 0.10 mm
F	2.00 ± 0.20 mm	N	0.50 ± 0.05 mm	V	0.20 ± 0.02 mm
G	2.50 ± 0.30 mm	O	3.50 ± 0.20 mm	X	0.80 ± 0.10 mm
H	2.80 ± 0.30 mm	P	1.60 +0.3/-0.10 mm	Z	0.25 ± 0.03 mm

Special Control Code	
Table 9	
Code	Description
E	Soft Termination

5. EXTERNAL DIMENSIONS

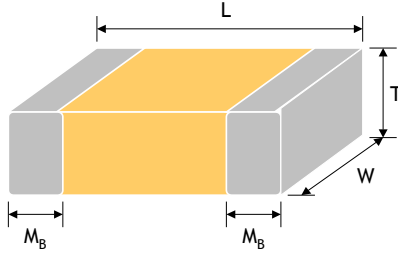
Size Inch (mm)	L (mm)	W (mm)	Code / T (mm)	M _B (mm)	
0402 (1005)	1.00±0.20	0.50±0.20	K	0.25 +0.05/-0.10	
0603(1608)	1.60±0.20	0.80±0.10	S	0.40±0.15	
	1.60±0.30	0.80±0.30	B		
0805(2012)	2.10±0.20	1.25±0.20	See No.4 Reference Table 8	0.50±0.20	
1206(3216)	3.30±0.30	1.60±0.20 +0.3/-0.1#		0.60±0.20	
1210(3225)	3.30±0.40	2.50±0.30		0.75±0.35	
1812(4532)	4.60±0.50	3.20±0.30		0.75±0.35	
2220 (5750)	5.70±0.50	5.00±0.40		0.85±0.35	

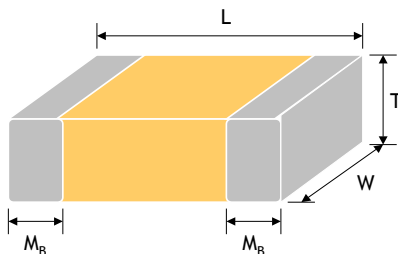

Fig. 5.1 The outline of MLCC

For 1206 P thickness products (P)

6. GENERAL ELECTRICAL DATA

Dielectric	C0G(NPO)	X7R/X7S
Size	1206, 1210	,0402,0603, 0805, 1206, 1210, 1812,2220
Rated voltage (WVDC)	630V, 1000V	10V, 16V, 25V, 50V, 100V, 250V, 630V, 1000V, 2000V, 3000V
Capacitance range	1.5pF ~ 22nF	220pF ~ 4.7μF
Capacitance tolerance	Reference to Table 5	
Tan δ	Cap. Range	Q Spec.
	Cap. <30pF	Q≥400+20C
	Cap. ≥30pF	Q≥1000
Capacitance & Tan δ Test condition	Measured at the condition of 30~70% related humidity	
	For 25°C at ambient temperature	
	Preconditioning for Class II MLCC : Perform a heat treatment at 150±10°C for 1 hour, then leave in ambient condition for 24±2 hours before measurement	
	Cap. Range	Test Condition
Cap. ≤1000pF	1.0±0.2Vrms, 1.0MHz±10%	
Cap. >1000pF	1.0±0.2Vrms, 1.0KHz±10%	
Insulation resistance at Ur	≥10GΩ or RxC≥500Ω-F, whichever is smaller	≥10GΩ or RxC≥100Ω-F, whichever is smaller
Operating temperature	-55°C to +125°C	
Capacitance characteristic	±30ppm/°C	X7R : ±15% X7S : ±22%
Termination	Cu/Ag polymer/Ni/Sn (lead-free termination)	

7. CAPACITANCE RANGE

7-1 C0G(NPO)

DIELECTRIC	NPO		
	SIZE	1206	1210
	RATED VOLTAGE (V)	630V	630V 1000V
0.1 (0R1)			
0.2 (0R2)			
0.3 (0R3)			
0.4 (0R4)			
0.5 (0R5)			
1.0 (1R0)			
1.2 (1R2)			
1.5 (1R5)	X		
1.8 (1R8)	X		
2.2 (2R2)	X		
2.7 (2R7)	X		
3.3 (3R3)	X		
3.9 (3R9)	X		
4.7 (4R7)	X		
5.6 (5R6)	X		
6.8 (6R8)	X		
8.2 (8R2)	X		
10 (100)	X	M	M
12 (120)	X	M	M
15 (150)	X	M	M
18 (180)	X	M	M
22 (220)	X	M	M
27 (270)	X	M	M
33 (330)	X	M	M
39 (390)	X	M	M
47 (470)	X	M	M
56 (560)	X	M	M
68 (680)	X	M	M
82 (820)	X	M	M
100 (101)	X	M	M
120 (121)	X	M	M
150 (151)	X	M	M
180 (181)	X	M	M
220 (221)	X	M	M
270 (271)	X	M	M
330 (331)	X	M	M
390 (391)	X	M	M
470 (471)	X	M	M
560 (561)	X	M	C
680 (681)	X	M	C
820 (821)	X	M	C
1000 (102)	X	M	E/F
1200 (122)		M	E/F
1500 (152)		M	F
1800 (182)		M	F
2200 (222)		M	F
2700 (272)		M	G
3300 (332)		M	G
3900 (392)		C	G
4700 (472)		C	G
5600 (562)		C	G
6800 (682)		E	G
8200 (822)		E	G
10000 (103)		E	G
12000 (123)			G
15000 (153)			G
18000 (183)			G
22000 (223)			G
27000 (273)			
33000 (333)			
39000 (393)			
47000 (473)			
56000 (563)			
68000 (683)			
82000 (823)			
100000 (104)			

Capacitance

7. CAPACITANCE RANGE

7-2 X7R

DIELECTRIC		X7R									
SIZE		0402			0603			0805			
RATED VOLTAGE (V)		16	10/16/25	50	10	16	25	50	100	250	630
Capacitance	100pF (101)										
	120pF (121)										
	150pF (151)										
	180pF (181)										
	220pF (221)		S	S	X/C	X/C	X/C	X/C	X	X	X
	270pF (271)		S	S	X/C	X/C	X/C	X/C	X	X	X
	330pF (331)		S	S	X/C	X/C	X/C	X/C	X	X	X
	390pF (391)		S	S	X/C	X/C	X/C	X/C	X	X	X
	470pF (471)		S	S	X/C	X/C	X/C	X/C	X	X	X
	560pF (561)		S	S	X/C	X/C	X/C	X/C	X	X	X
	680pF (681)		S	S	X/C	X/C	X/C	X/C	X	X	X
	820pF (821)		S	S	X/C	X/C	X/C	X/C	X	X	X
	1,000pF (102)		S	S	X/C	X/C	X/C	X/C	X	X	X
	1,200pF (122)		S	S	X/C	X/C	X/C	X/C	X	X	
	1,500pF (152)		S	S	X/C	X/C	X/C	X/C	X	X	
	1,800pF (182)		S	S	X/C	X/C	X/C	X/C	X	X	
	2,200pF (222)		S	S	X/C	X/C	X/C	X/C	X	X	
	2,700pF (272)		S	S	X/C	X/C	X/C	X/C	X	X	
	3,300pF (332)		S	S	X/C	X/C	X/C	X/C	X	X	
	3,900pF (392)		S	S	X/C	X/C	X/C	X/C	X	X	
	4,700pF (472)		S	S	X/C	X/C	X/C	X/C	X	X	
	5,600pF (562)		S	S	X/C	X/C	X/C	X/C	X	M	
	6,800pF (682)		S	S	X/C	X/C	X/C	X/C	X	C	
	8,200pF (822)		S	S	X/C	X/C	X/C	X/C	X	C	
	0.010μF (103)		S	S	X/C	X/C	X/C	X/C	X	C	
	0.012μF (123)		S	S	X/C	X/C	X/C	X/C	X	C	
	0.015μF (153)		S	S	X/C	X/C	X/C	X/C	X	C	
	0.018μF (183)		S	S	X/C	X/C	X/C	X/C	X	C	
	0.022μF (223)		S	S	X/C	X/C	X/C	X/C	X	C	
	0.027μF (273)		S	S	X/C	X/C	M/C	M/C	M		
	0.033μF (333)		S	B	X/C	X/C	M/C	M/C	M		
	0.039μF (393)		S	B	X/C	X/C	M/C	M/C	M		
	0.047μF (473)		S	B	X/C	X/C	M/C	M/C	M		
	0.056μF (563)	K	S	B	X/C	X/C	M/C	M/C	M		
	0.068μF (683)	K	S	B	X/C	X/C	M/C	M/C	M		
	0.082μF (823)	K	S	B	X/C	X/C	M/C	M/C	M		
	0.10μF (104)	K	S	B	X/C	X/C	C	C	C		
	0.12μF (124)		B		X	X	C	C	C		
	0.15μF (154)		B		X	X	C	C	C		
	0.18μF (184)		B		X	X	C	C	C		
	0.22μF (224)		B		X	X	C	C	C		
	0.27μF (274)				C	C	C	C			
	0.33μF (334)				C	C	C	C			
	0.39μF (394)				C	C	C	C			
	0.47μF (474)				C	C	C	C			
	0.56μF (564)				C	C					
	0.68μF (684)				C	C	I	I			
0.82μF (824)											
1.0μF (105)					I	I	I	I			
1.2μF (125)											
1.5μF (155)											
1.8μF (185)											
2.2μF (225)											
2.7μF (275)											
3.3μF (335)											
3.9μF (395)											
4.7μF (475)											

7. CAPACITANCE RANGE

7-2 X7R

DIELECTRIC		X7R									
SIZE		1206									
RATED VOLTAGE (V)		10	16	25	50	100	250	500	630	1000	2000
Capacitance	100pF (101)										
	120pF (121)										
	150pF (151)										
	180pF (181)										
	220pF (221)	X	X	X	X	X	X	X	X	X	X
	270pF (271)	X	X	X	X	X	X	X	X	X	X
	330pF (331)	X	X	X	X	X	X	X	X	X	X
	390pF (391)	X	X	X	X	X	X	X	X	X	X
	470pF (471)	X	X	X	X	X	X	X	X	X	X
	560pF (561)	X	X	X	X	X	X	X	X	X	X
	680pF (681)	X	X	X	X	X	X	X	X	M	C*
	820pF (821)	X	X	X	X	X	X	X	X	M	C*
	1,000pF (102)	X	X	X	X	X	X	X	X	C	C*
	1,200pF (122)	X	X	X	X	X	X	X	X	E	
	1,500pF (152)	X	X	X	X	X	X	X	X	E	
	1,800pF (182)	X	X	X	X	X	X	X	X	E	
	2,200pF (222)	X	X	X	X	X	X	X	X	E	
	2,700pF (272)	X	X	X	X	X	X	X	X	E	
	3,300pF (332)	X	X	X	X	X	X	X	X	E	
	3,900pF (392)	X	X	X	X	X	X	X	X	E	
	4,700pF (472)	X	X	X	X	X	X	X	X	E	
	5,600pF (562)	X	X	X	X	X	X	X	X		
	6,800pF (682)	X	X	X	X	X	X	M	M		
	8,200pF (822)	X	X	X	X	X	X	M	M		
	0.010μF (103)	X	X	X	X	X	M	M	M		
	0.012μF (123)	X	X	X	X	X	C	C	C		
	0.015μF (153)	X	X	X	X	X	C	E	E		
	0.018μF (183)	X	X	X	X	X	C	E	E		
	0.022μF (223)	X	X	X	X	X	E	E	E		
	0.027μF (273)	X	X	X	X	X	E				
	0.033μF (333)	X	X	X	X	X	E				
	0.039μF (393)	X	X	X	X	X	E				
	0.047μF (473)	X	X	X	X	X	E				
	0.056μF (563)	X	X	X	X	M					
	0.068μF (683)	X	X	X	X	C					
	0.082μF (823)	X	X	X	X	C					
	0.10μF (104)	X	X	X	X	E					
	0.12μF (124)	X	X	X	X						
	0.15μF (154)	X	X	X	X						
	0.18μF (184)	X	X	M	M						
	0.22μF (224)	X	X	M	M						
	0.27μF (274)	X	X	C	C						
	0.33μF (334)	X	X	C	C						
	0.39μF (394)	C	C	E	E						
	0.47μF (474)	C	C	E	E						
	0.56μF (564)	C	C	P	P						
	0.68μF (684)	C	C	P	P						
0.82μF (824)	E	E	P	P							
1.0μF (105)	P	P	P	P							
1.2μF (125)	P	P	P	P							
1.5μF (155)	P	P	P	P							
1.8μF (185)	P	P	P	P							
2.2μF (225)	P	P	P	P							
2.7μF (275)											
3.3μF (335)											
3.9μF (395)											
4.7μF (475)											

7. CAPACITANCE RANGE

7-2 X7R

DIELECTRIC		X7R							
SIZE		1210							
RATED VOLTAGE (V)		10	16	25	50	100	250	630	1000
Capacitance	100pF (101)								
	120pF (121)								
	150pF (151)								
	180pF (181)								
	220pF (221)	M	M	M	M	M	M	M	M
	270pF (271)	M	M	M	M	M	M	M	M
	330pF (331)	M	M	M	M	M	M	M	M
	390pF (391)	M	M	M	M	M	M	M	M
	470pF (471)	M	M	M	M	M	M	M	M
	560pF (561)	M	M	M	M	M	M	M	M
	680pF (681)	M	M	M	M	M	M	M	M
	820pF (821)	M	M	M	M	M	M	M	M
	1,000pF (102)	M	M	M	M	M	M	M	C
	1,200pF (122)	M	M	M	M	M	M	M	E
	1,500pF (152)	M	M	M	M	M	M	M	E
	1,800pF (182)	M	M	M	M	M	M	M	E
	2,200pF (222)	M	M	M	M	M	M	M	F
	2,700pF (272)	M	M	M	M	M	M	M	F
	3,300pF (332)	M	M	M	M	M	M	M	F
	3,900pF (392)	M	M	M	M	M	M	M	G
	4,700pF (472)	M	M	M	M	M	M	M	G
	5,600pF (562)	M	M	M	M	M	M	M	C
	6,800pF (682)	M	M	M	M	M	M	M	C
	8,200pF (822)	M	M	M	M	M	M	M	G
	0.010μF (103)	M	M	M	M	M	M	M	G
	0.012μF (123)	M	M	M	M	M	M	M	G
	0.015μF (153)	M	M	M	M	M	M	M	G
	0.018μF (183)	M	M	M	M	M	M	C	E
	0.022μF (223)	M	M	M	M	M	M	C	E
	0.027μF (273)	M	M	M	M	M	M	C	E
	0.033μF (333)	M	M	M	M	M	M	E	E
	0.039μF (393)	M	M	M	M	M	M	E	F
	0.047μF (473)	M	M	M	M	M	M	E	G
	0.056μF (563)	M	M	M	M	M	M	E	
	0.068μF (683)	M	M	M	M	M	M	F	
	0.082μF (823)	M	M	M	M	M	M	F	
	0.10μF (104)	M	M	M	M	M	M	F	
	0.12μF (124)	M	M	C	C	E			
	0.15μF (154)	M	M	C	C	E			
	0.18μF (184)	M	M	E	E	E			
0.22μF (224)	M	M	E	E	E				
0.27μF (274)	M	M	M	M	F				
0.33μF (334)	M	M	M	M	F				
0.39μF (394)	M	M	F	F	G				
0.47μF (474)	M	M	F	F	G				
0.56μF (564)	M	M	F	F	G				
0.68μF (684)	M	M	F	F	G				
0.82μF (824)	C	C	F	F	G				
1.0μF (105)	C	C	F	F	G				
1.2μF (125)	F	F	F	F	G				
1.5μF (155)	F	F	F	F	G				
1.8μF (185)	G	G	G	G	G				
2.2μF (225)	G	G	G	G	G				
2.7μF (275)	G	G	G	G	G				
3.3μF (335)	G	G	G	G	G				
3.9μF (395)	G	G	G	G	G				
4.7μF (475)	G	G	G	G	G				
5.6μF (565)	G	G	G	G					
6.8μF (685)	G	G	G	G					
8.2μF (825)	G	G	G	G					
10μF (106)	G	G	G	G					

7. CAPACITANCE RANGE

7-2 X7R

DIELECTRIC		X7R									
SIZE		1812									
RATED VOLTAGE (V)		10	16	25	50	100	250	630	1000	2000	3000
100pF (101)											
120pF (121)											
150pF (151)											
180pF (181)											
220pF (221)											
270pF (271)	C	C	C	C	C	C	C	C	C	C	F*
330pF (331)	C	C	C	C	C	C	C	C	C	C	F*
390pF (391)	C	C	C	C	C	C	C	C	C	C	F*
470pF (471)	C	C	C	C	C	C	C	C	C	C	F*
560pF (561)	C	C	C	C	C	C	C	C	C	C	F*
680pF (681)	C	C	C	C	C	C	C	C	C	C	F*
820pF (821)	C	C	C	C	C	C	C	C	C	C	F*
1,000pF (102)	C	C	C	C	C	C	C	C	C	E	F*
1,200pF (122)	C	C	C	C	C	C	C	C	C	F	G*
1,500pF (152)	C	C	C	C	C	C	C	C	C	F	G*
1,800pF (182)	C	C	C	C	C	C	C	C	C	G*	G*
2,200pF (222)	C	C	C	C	C	C	C	C	C	G*	
2,700pF (272)	C	C	C	C	C	C	C	C	C	G*	
3,300pF (332)	C	C	C	C	C	C	C	C	E	G*	
3,900pF (392)	C	C	C	C	C	C	C	C	F	G*	
4,700pF (472)	C	C	C	C	C	C	C	C	F	G*	
5,600pF (562)	C	C	C	C	C	C	C	C	G		
6,800pF (682)	C	C	C	C	C	C	C	C	G		
8,200pF (822)	C	C	C	C	C	C	C	C	G		
0.010μF (103)	C	C	C	C	C	C	C	C	G		
0.012μF (123)	C	C	C	C	C	C	C	C			
0.015μF (153)	C	C	C	C	C	C	C	C			
0.018μF (183)	C	C	C	C	C	C	C	E			
0.022μF (223)	C	C	C	C	C	C	C	E			
0.027μF (273)	C	C	C	C	C	C	C	F			
0.033μF (333)	C	C	C	C	C	C	C	F			
0.039μF (393)	C	C	C	C	C	C	C	G			
0.047μF (473)	C	C	C	C	C	C	C	G			
0.056μF (563)	C	C	C	C	C	C	E	G			
0.068μF (683)	C	C	C	C	C	C	E	G			
0.082μF (823)	C	C	C	C	C	C	E	G			
0.10μF (104)	C	C	C	C	C	C	E	G			
0.12μF (124)	C	C	C	C	C	C	F				
0.15μF (154)	C	C	C	C	C	C	F				
0.18μF (184)	C	C	C	C	C	C	G				
0.22μF (224)	C	C	C	C	C	E	G				
0.27μF (274)	C	C	C	C	C	E	G				
0.33μF (334)	C	C	C	C	F	G					
0.39μF (394)	C	C	C	C	F	G					
0.47μF (474)	C	C	C	C	G	G					
0.56μF (564)	C	C	C	C	G						
0.68μF (684)	C	C	C	C	G						
0.82μF (824)	C	C	C	C	G						
1.0μF (105)	C	C	C	C	G						
1.2μF (125)	C	C	C	C							
1.5μF (155)	C	C	C	C							
1.8μF (185)	E	E	E	E							
2.2μF (225)	E	E	E	E							
2.7μF (275)	F	F	F	F							
3.3μF (335)	F	F	F	F							
3.9μF (395)	F	F	F	F							
4.7μF (475)	G	G	G	G							
5.6μF (565)	G	G									
6.8μF (685)	G	G									
8.2μF (825)	G	G									
10.0μF (106)	G	G									

Capacitance

7. CAPACITANCE RANGE

7-2 X7R

DIELECTRIC SIZE	X7R									
	2220									
RATED VOLTAGE (V)	10	16	25	50	100	250	630	1000	2000	3000
100pF (101)										
120pF (121)										
150pF (151)										
180pF (181)										
220pF (221)										
270pF (271)										F*
330pF (331)										F*
390pF (391)										F*
470pF (471)										F*
560pF (561)										F*
680pF (681)										F*
820pF (821)										F*
1,000pF (102)	F	F	F	F	F	F	F	F	F	F*
1,200pF (122)	F	F	F	F	F	F	F	F	F	G*
1,500pF (152)	F	F	F	F	F	F	F	F	F	G*
1,800pF (182)	F	F	F	F	F	F	F	F	F	G*
2,200pF (222)	F	F	F	F	F	F	F	F	F	G*
2,700pF (272)	F	F	F	F	F	F	F	F	F*	G*
3,300pF (332)	F	F	F	F	F	F	F	F	F*	G*
3,900pF (392)	F	F	F	F	F	F	F	F	F*	G*
4,700pF (472)	F	F	F	F	F	F	F	F	F*	G*
5,600pF (562)	F	F	F	F	F	F	F	F	F*	G*
6,800pF (682)	F	F	F	F	F	F	F	F	G*	G*
8,200pF (822)	F	F	F	F	F	F	F	G	G*	G*
0.010μF (103)	F	F	F	F	F	F	F	G	G*	G*
0.012μF (123)	F	F	F	F	F	F	F	G	H*	
0.015μF (153)	F	F	F	F	F	F	F	G	H*	
0.018μF (183)	F	F	F	F	F	F	F	H	H*	
0.022μF (223)	F	F	F	F	F	F	F	H		
0.027μF (273)	F	F	F	F	F	F	F	H		
0.033μF (333)	F	F	F	F	F	F	F	H		
0.039μF (393)	F	F	F	F	F	F	F	H		
0.047μF (473)	F	F	F	F	F	F	F	H		
0.056μF (563)	F	F	F	F	F	F	F	H		
0.068μF (683)	F	F	F	F	F	F	F	F		
0.082μF (823)	F	F	F	F	F	F	G	F		
0.10μF (104)	F	F	F	F	F	F	G	F		
0.12μF (124)	F	F	F	F	F	F	H			
0.15μF (154)	F	F	F	F	F	F	H			
0.18μF (184)	F	F	F	F	F	F	H			
0.22μF (224)	F	F	F	F	F	F	H			
0.27μF (274)	F	F	F	F	F	F				
0.33μF (334)	F	F	F	F	F	F				
0.39μF (394)	F	F	F	F	F	F				
0.47μF (474)	F	F	F	F	F	F				
0.56μF (564)	F	F	F	F	F	F				
0.68μF (684)	F	F	F	F	F	F				
0.82μF (824)	F	F	F	F	F	F				
1.0μF (105)	F	F	F	F	F	F				
1.2μF (125)	F	F	F	F	F	G				
1.5μF (155)	F	F	F	F	F	G				
1.8μF (185)	F	F	F	F	G					
2.2μF (225)	F	F	F	F	G					
2.7μF (275)	F	F	F	F						
3.3μF (335)	F	F	F	F						
3.9μF (395)	F	F	F	F						
4.7μF (475)	F	F	F	F						
5.6μF (565)	F	F	F	F						
6.8μF (685)	F	F	F	F						
8.2μF (825)	G	G	G	G						
10.0μF (106)	G	G	G	G						
12.0μF (126)	H	H								
15.0μF (156)	H	H								
18.0μF (186)	H	H								
22.0μF (226)	H	H								

Capacitance

7. CAPACITANCE RANGE

7-3 X7S

DIELECTRIC		X7S			
SIZE		0805		1206	
RATED VOLTAGE (V)		10	16	10	16
Capacitance	0.10μF (104)				
	0.12μF (124)				
	0.15μF (154)				
	0.18μF (184)				
	0.22μF (224)				
	0.27μF (274)				
	0.33μF (334)				
	0.39μF (394)				
	0.47μF (474)				
	0.56μF (564)				
	0.68μF (684)				
	0.82μF (824)				
	1.0μF (105)				
	1.2μF (125)				
	1.5μF (155)				
	1.8μF (185)				
	2.2μF (225)			P	P
2.7μF (275)					
3.3μF (335)					
3.9μF (395)					
4.7μF (475)					

8. RELIABILITY TEST CONDITIONS AND REQUIREMENTS

No.	AEC-Q200 Test Item	AEC-Q200 Test Condition	Requirements																																																													
1	Pre-and Post-Stress Electrical Test	---	---																																																													
2	High Temperature Exposure (Storage) MIL-STD-202 Method 108	<p>* Test temp. : 150±3°C. * Unpowered. * Test time : 1000 +24/-0 hrs. * Measurement to be made after keeping at room temp. for 24±2 hrs.</p>	<p>* No remarkable damage. * Cap. change : COG within ±2.5% or ±0.25pF, whichever is larger. X7R/X7S within ±10.0%. * D.F. value :COG : To meet the initial requirement. X7R/X7S : D.F.≤200% of initial requirement. * X7R/X7S :</p> <table border="1"> <thead> <tr> <th>Rated vol.</th> <th>D.F.≤</th> <th colspan="2">Exception of D.F.≤</th> </tr> </thead> <tbody> <tr> <td rowspan="3">≥100V</td> <td rowspan="3">≤3%</td> <td>≤6%</td> <td>1206 ≥ 0.47μF</td> </tr> <tr> <td>≤7.5%</td> <td>0603 ≥ 0.068μF; 0805 > 0.1μF; 1206 ≥ 1μF; 1210 ≥ 2.2μF</td> </tr> <tr> <td>≤20%</td> <td>0805 > 0.22μF; 1210 ≥ 3.3μF</td> </tr> <tr> <td rowspan="3">50V</td> <td rowspan="3">≤3%</td> <td>≤6%</td> <td>0201(50V); 0603 ≥ 0.047μF; 0805 ≥ 0.18μF; 1206 ≥ 0.47μF</td> </tr> <tr> <td>≤10%</td> <td>0201 ≥ 0.01μF; 1210 ≥ 3.3μF</td> </tr> <tr> <td>≤20%</td> <td>0402 ≥ 0.012μF; 0603 > 0.1μF; 0805/X7R > 0.47μF; 1206 ≥ 2.2μF; 1210 ≥ 10μF</td> </tr> <tr> <td>35V</td> <td>≤5%</td> <td>≤20%</td> <td>0603 ≥ 1μF; 0805 ≥ 2.2μF; 1206 ≥ 2.2μF; 1210 ≥ 10μF</td> </tr> <tr> <td rowspan="3">25V</td> <td rowspan="3">≤5%</td> <td>≤10%</td> <td>0201 ≥ 0.01μF; 0805 ≥ 1μF; 1210 ≥ 10μF</td> </tr> <tr> <td>≤14%</td> <td>0603 ≥ 0.33μF</td> </tr> <tr> <td>≤15%</td> <td>0201 ≥ 0.1μF; 0402 ≥ 0.056μF; 0603 ≥ 0.47μF; 0805 ≥ 2.2μF; 1206 ≥ 4.7μF; 1210 ≥ 22μF</td> </tr> <tr> <td rowspan="2">16V</td> <td rowspan="2">≤5%</td> <td>≤20%</td> <td>0402 ≥ 0.47μF</td> </tr> <tr> <td>≤10%</td> <td>0603 ≥ 0.15μF; 0805 ≥ 0.68μF; 1206 ≥ 2.2μF; 1210 ≥ 4.7μF</td> </tr> <tr> <td rowspan="2">10V</td> <td rowspan="2">≤7.5%</td> <td>≤15%</td> <td>0201 ≥ 0.022μF; 0402 ≥ 0.033μF; 0603 > 0.47μF; 0805 ≥ 2.2μF; 1206 ≥ 4.7μF; 1210 ≥ 22μF</td> </tr> <tr> <td>≤20%</td> <td>0201 ≥ 0.012μF; 0402 ≥ 0.22μF; 0603 ≥ 0.33μF; 0805 ≥ 2.2μF; 1206 ≥ 2.2μF; 1210 ≥ 22μF</td> </tr> <tr> <td>6.3V</td> <td>≤15%</td> <td>≤30%</td> <td>0201 ≥ 0.1μF; 0402 ≥ 1μF; 0603 ≥ 10μF; 0805 ≥ 4.7μF; 1206 ≥ 47μF; 1210 ≥ 100μF</td> </tr> <tr> <td>4V</td> <td>≤20%</td> <td>--</td> <td>--</td> </tr> </tbody> </table> <p>* I.R. : To meet the initial requirement. Class II (X7R/X7S)</p> <table border="1"> <thead> <tr> <th>Rated voltage</th> <th>I.R.</th> </tr> </thead> <tbody> <tr> <td>100V : All X7R/X7S</td> <td rowspan="6">≥1GΩ or RxC≥10Ω-F, whichever is smaller</td> </tr> <tr> <td>50V : 0402>0.01μF, 0603≥1μF, 0805≥1μF, 1206≥4.7μF, 1210≥4.7μF</td> </tr> <tr> <td>35V : 0805≥2.2μF, 1206≥2.2μF, 1210≥10μF</td> </tr> <tr> <td>25V : 0402≥1μF, 0603≥2.2μF, 0805≥2.2μF, 1206≥10μF, 1210≥10μF</td> </tr> <tr> <td>16V : 0402≥0.22μF, 0603≥1μF, 0805≥2.2μF, 1206≥10μF, 1210≥47μF</td> </tr> <tr> <td>10V : 0402≥0.47μF, 0603≥0.47μF, 0805≥2.2μF, 1206≥4.7μF, 1210≥47μF</td> </tr> </tbody> </table>	Rated vol.	D.F.≤	Exception of D.F.≤		≥100V	≤3%	≤6%	1206 ≥ 0.47μF	≤7.5%	0603 ≥ 0.068μF; 0805 > 0.1μF; 1206 ≥ 1μF; 1210 ≥ 2.2μF	≤20%	0805 > 0.22μF; 1210 ≥ 3.3μF	50V	≤3%	≤6%	0201(50V); 0603 ≥ 0.047μF; 0805 ≥ 0.18μF; 1206 ≥ 0.47μF	≤10%	0201 ≥ 0.01μF; 1210 ≥ 3.3μF	≤20%	0402 ≥ 0.012μF; 0603 > 0.1μF; 0805/X7R > 0.47μF; 1206 ≥ 2.2μF; 1210 ≥ 10μF	35V	≤5%	≤20%	0603 ≥ 1μF; 0805 ≥ 2.2μF; 1206 ≥ 2.2μF; 1210 ≥ 10μF	25V	≤5%	≤10%	0201 ≥ 0.01μF; 0805 ≥ 1μF; 1210 ≥ 10μF	≤14%	0603 ≥ 0.33μF	≤15%	0201 ≥ 0.1μF; 0402 ≥ 0.056μF; 0603 ≥ 0.47μF; 0805 ≥ 2.2μF; 1206 ≥ 4.7μF; 1210 ≥ 22μF	16V	≤5%	≤20%	0402 ≥ 0.47μF	≤10%	0603 ≥ 0.15μF; 0805 ≥ 0.68μF; 1206 ≥ 2.2μF; 1210 ≥ 4.7μF	10V	≤7.5%	≤15%	0201 ≥ 0.022μF; 0402 ≥ 0.033μF; 0603 > 0.47μF; 0805 ≥ 2.2μF; 1206 ≥ 4.7μF; 1210 ≥ 22μF	≤20%	0201 ≥ 0.012μF; 0402 ≥ 0.22μF; 0603 ≥ 0.33μF; 0805 ≥ 2.2μF; 1206 ≥ 2.2μF; 1210 ≥ 22μF	6.3V	≤15%	≤30%	0201 ≥ 0.1μF; 0402 ≥ 1μF; 0603 ≥ 10μF; 0805 ≥ 4.7μF; 1206 ≥ 47μF; 1210 ≥ 100μF	4V	≤20%	--	--	Rated voltage	I.R.	100V : All X7R/X7S	≥1GΩ or RxC≥10Ω-F, whichever is smaller	50V : 0402>0.01μF, 0603≥1μF, 0805≥1μF, 1206≥4.7μF, 1210≥4.7μF	35V : 0805≥2.2μF, 1206≥2.2μF, 1210≥10μF	25V : 0402≥1μF, 0603≥2.2μF, 0805≥2.2μF, 1206≥10μF, 1210≥10μF	16V : 0402≥0.22μF, 0603≥1μF, 0805≥2.2μF, 1206≥10μF, 1210≥47μF	10V : 0402≥0.47μF, 0603≥0.47μF, 0805≥2.2μF, 1206≥4.7μF, 1210≥47μF
Rated vol.	D.F.≤	Exception of D.F.≤																																																														
≥100V	≤3%	≤6%	1206 ≥ 0.47μF																																																													
		≤7.5%	0603 ≥ 0.068μF; 0805 > 0.1μF; 1206 ≥ 1μF; 1210 ≥ 2.2μF																																																													
		≤20%	0805 > 0.22μF; 1210 ≥ 3.3μF																																																													
50V	≤3%	≤6%	0201(50V); 0603 ≥ 0.047μF; 0805 ≥ 0.18μF; 1206 ≥ 0.47μF																																																													
		≤10%	0201 ≥ 0.01μF; 1210 ≥ 3.3μF																																																													
		≤20%	0402 ≥ 0.012μF; 0603 > 0.1μF; 0805/X7R > 0.47μF; 1206 ≥ 2.2μF; 1210 ≥ 10μF																																																													
35V	≤5%	≤20%	0603 ≥ 1μF; 0805 ≥ 2.2μF; 1206 ≥ 2.2μF; 1210 ≥ 10μF																																																													
25V	≤5%	≤10%	0201 ≥ 0.01μF; 0805 ≥ 1μF; 1210 ≥ 10μF																																																													
		≤14%	0603 ≥ 0.33μF																																																													
		≤15%	0201 ≥ 0.1μF; 0402 ≥ 0.056μF; 0603 ≥ 0.47μF; 0805 ≥ 2.2μF; 1206 ≥ 4.7μF; 1210 ≥ 22μF																																																													
16V	≤5%	≤20%	0402 ≥ 0.47μF																																																													
		≤10%	0603 ≥ 0.15μF; 0805 ≥ 0.68μF; 1206 ≥ 2.2μF; 1210 ≥ 4.7μF																																																													
10V	≤7.5%	≤15%	0201 ≥ 0.022μF; 0402 ≥ 0.033μF; 0603 > 0.47μF; 0805 ≥ 2.2μF; 1206 ≥ 4.7μF; 1210 ≥ 22μF																																																													
		≤20%	0201 ≥ 0.012μF; 0402 ≥ 0.22μF; 0603 ≥ 0.33μF; 0805 ≥ 2.2μF; 1206 ≥ 2.2μF; 1210 ≥ 22μF																																																													
6.3V	≤15%	≤30%	0201 ≥ 0.1μF; 0402 ≥ 1μF; 0603 ≥ 10μF; 0805 ≥ 4.7μF; 1206 ≥ 47μF; 1210 ≥ 100μF																																																													
4V	≤20%	--	--																																																													
Rated voltage	I.R.																																																															
100V : All X7R/X7S	≥1GΩ or RxC≥10Ω-F, whichever is smaller																																																															
50V : 0402>0.01μF, 0603≥1μF, 0805≥1μF, 1206≥4.7μF, 1210≥4.7μF																																																																
35V : 0805≥2.2μF, 1206≥2.2μF, 1210≥10μF																																																																
25V : 0402≥1μF, 0603≥2.2μF, 0805≥2.2μF, 1206≥10μF, 1210≥10μF																																																																
16V : 0402≥0.22μF, 0603≥1μF, 0805≥2.2μF, 1206≥10μF, 1210≥47μF																																																																
10V : 0402≥0.47μF, 0603≥0.47μF, 0805≥2.2μF, 1206≥4.7μF, 1210≥47μF																																																																
3	Destructive Physical Analysis EIA-469	Per EIA-469.	* No defects or abnormalities.																																																													
4	Temperature Cycling JESD22 Method JA-104	<p>* Conduct 1000 cycles according to the temperatures and time.</p> <table border="1"> <thead> <tr> <th>Step</th> <th>Temp.(°C)</th> <th>Time(min.)</th> </tr> </thead> <tbody> <tr> <td>1</td> <td>-55°C +0/-3</td> <td>30±1</td> </tr> <tr> <td>2</td> <td>+125°C +3/-0</td> <td>30±1</td> </tr> </tbody> </table> <p>* Before initial measurement : Perform 150 +0/-10°C for 1 hr and then set for 24±2 hrs at room temp. * Measurement to be made after keeping at room temp. for 24±2 hrs.</p>	Step	Temp.(°C)	Time(min.)	1	-55°C +0/-3	30±1	2	+125°C +3/-0	30±1	<p>* No remarkable damage. * Cap. change : COG : Within ±2.5% or ±0.25pF, whichever is larger. X7R/X7S within ±10.0%. * D.F. value :COG : To meet the initial requirement. X7R/X7S : D.F.≤200% of initial requirement. * I.R. : To meet the initial requirement. Class II (X7R/X7S)</p> <table border="1"> <thead> <tr> <th>Rated voltage</th> <th>I.R.</th> </tr> </thead> <tbody> <tr> <td>100V : All X7R/X7S</td> <td rowspan="6">≥1GΩ or RxC≥10Ω-F, whichever is smaller</td> </tr> <tr> <td>50V : 0402>0.01μF, 0603≥1μF, 0805≥1μF, 1206≥4.7μF, 1210≥4.7μF</td> </tr> <tr> <td>35V : 0805≥2.2μF, 1206≥2.2μF, 1210≥10μF</td> </tr> <tr> <td>25V : 0402≥1μF, 0603≥2.2μF, 0805≥2.2μF, 1206≥10μF, 1210≥10μF</td> </tr> <tr> <td>16V : 0402≥0.22μF, 0603≥1μF, 0805≥2.2μF, 1206≥10μF, 1210≥47μF</td> </tr> <tr> <td>10V : 0402≥0.47μF, 0603≥0.47μF, 0805≥2.2μF, 1206≥4.7μF, 1210≥47μF</td> </tr> </tbody> </table>	Rated voltage	I.R.	100V : All X7R/X7S	≥1GΩ or RxC≥10Ω-F, whichever is smaller	50V : 0402>0.01μF, 0603≥1μF, 0805≥1μF, 1206≥4.7μF, 1210≥4.7μF	35V : 0805≥2.2μF, 1206≥2.2μF, 1210≥10μF	25V : 0402≥1μF, 0603≥2.2μF, 0805≥2.2μF, 1206≥10μF, 1210≥10μF	16V : 0402≥0.22μF, 0603≥1μF, 0805≥2.2μF, 1206≥10μF, 1210≥47μF	10V : 0402≥0.47μF, 0603≥0.47μF, 0805≥2.2μF, 1206≥4.7μF, 1210≥47μF																																											
Step	Temp.(°C)	Time(min.)																																																														
1	-55°C +0/-3	30±1																																																														
2	+125°C +3/-0	30±1																																																														
Rated voltage	I.R.																																																															
100V : All X7R/X7S	≥1GΩ or RxC≥10Ω-F, whichever is smaller																																																															
50V : 0402>0.01μF, 0603≥1μF, 0805≥1μF, 1206≥4.7μF, 1210≥4.7μF																																																																
35V : 0805≥2.2μF, 1206≥2.2μF, 1210≥10μF																																																																
25V : 0402≥1μF, 0603≥2.2μF, 0805≥2.2μF, 1206≥10μF, 1210≥10μF																																																																
16V : 0402≥0.22μF, 0603≥1μF, 0805≥2.2μF, 1206≥10μF, 1210≥47μF																																																																
10V : 0402≥0.47μF, 0603≥0.47μF, 0805≥2.2μF, 1206≥4.7μF, 1210≥47μF																																																																

8. RELIABILITY TEST CONDITIONS AND REQUIREMENTS

No.																					
5	Moisture Resistance MIL-STD-202 Method 106	* Test temp. : 25~65°C. * Humidity : 80~100% RH. * Test time : 10 cycles, t=24hrs/cycle. * Measurement to be made after keeping at room temp. for 24±2 hrs.	* No remarkable damage. * Cap. change : C0G : Within ±3.0% or ±0.3pF, whichever is larger. X7R/X7S within ±12.5%. * D.F. value :. C0G : Q≥350 for Cap.>30pF. Q≥275+2.5C for 10pF≤Cap.≤30pF. Q≥200+10C for Cap.<10pF. X7R/X7S : D.F.≤200% of initial requirement. * I.R. : ≥1GΩ or RxC≥50Ω-F, whichever is smaller. Class II (X7R/X7S) <table border="1" data-bbox="746 734 1487 981"> <thead> <tr> <th>Rated voltage</th> <th>I.R.</th> </tr> </thead> <tbody> <tr> <td>100V : All X7R/X7S</td> <td rowspan="6">≥1GΩ or RxC≥50Ω-F, whichever is smaller</td> </tr> <tr> <td>50V : 0402>0.01μF, 0603≥1μF, 0805≥1μF, 1206≥4.7μF, 1210≥4.7μF</td> </tr> <tr> <td>35V : 0805≥2.2μF, 1206≥2.2μF, 1210≥10μF</td> </tr> <tr> <td>25V : 0402≥1μF, 0603≥2.2μF, 0805≥2.2μF, 1206≥10μF, 1210≥10μF</td> </tr> <tr> <td>16V : 0402≥0.22μF, 0603≥1μF, 0805≥2.2μF, 1206≥10μF, 1210≥47μF</td> </tr> <tr> <td>10V : 0402≥0.47μF, 0603≥0.47μF, 0805≥2.2μF, 1206≥4.7μF, 1210≥47μF</td> </tr> </tbody> </table>	Rated voltage	I.R.	100V : All X7R/X7S	≥1GΩ or RxC≥50Ω-F, whichever is smaller	50V : 0402>0.01μF, 0603≥1μF, 0805≥1μF, 1206≥4.7μF, 1210≥4.7μF	35V : 0805≥2.2μF, 1206≥2.2μF, 1210≥10μF	25V : 0402≥1μF, 0603≥2.2μF, 0805≥2.2μF, 1206≥10μF, 1210≥10μF	16V : 0402≥0.22μF, 0603≥1μF, 0805≥2.2μF, 1206≥10μF, 1210≥47μF	10V : 0402≥0.47μF, 0603≥0.47μF, 0805≥2.2μF, 1206≥4.7μF, 1210≥47μF									
Rated voltage	I.R.																				
100V : All X7R/X7S	≥1GΩ or RxC≥50Ω-F, whichever is smaller																				
50V : 0402>0.01μF, 0603≥1μF, 0805≥1μF, 1206≥4.7μF, 1210≥4.7μF																					
35V : 0805≥2.2μF, 1206≥2.2μF, 1210≥10μF																					
25V : 0402≥1μF, 0603≥2.2μF, 0805≥2.2μF, 1206≥10μF, 1210≥10μF																					
16V : 0402≥0.22μF, 0603≥1μF, 0805≥2.2μF, 1206≥10μF, 1210≥47μF																					
10V : 0402≥0.47μF, 0603≥0.47μF, 0805≥2.2μF, 1206≥4.7μF, 1210≥47μF																					
6	Biased Humidity MIL-STD-202 Method 103	* Test temp. : 85±3°C. * Humidity : 85±5%RH. * Test time : 1000 +24/-0 hrs. * To apply voltage : Rated voltage (max. 100Vdc) and 1.3~1.5Vdc (add 100k ohm resistor). * Before initial measurement (Class II only) : To apply test voltage for 1hr at test temp. and then set for 24±2 hrs at room temp. * Measurement to be made after keeping at room temp. for 24±2 hrs.	* No remarkable damage. * Cap. change : C0G : Within ±3.0% or ±0.3pF, whichever is larger. X7R/X7S within ±12.5%. * D.F. value : C0G : Q≥200 for Cap.≥30pF. Q≥100+10/3C for Cap.<30pF. X7R/X7S : D.F.≤200% of initial requirement. * I.R. : ≥500MΩ or RxC≥25Ω-F, whichever is smaller. Class II (X7R/X7S) for rated voltage test <table border="1" data-bbox="746 1384 1487 1630"> <thead> <tr> <th>Rated voltage</th> <th>I.R.</th> </tr> </thead> <tbody> <tr> <td>100V : All X7R/X7S</td> <td rowspan="6">≥500MΩ or RxC≥5Ω-F, whichever is smaller</td> </tr> <tr> <td>50V : 0402>0.01μF, 0603≥1μF, 0805≥1μF, 1206≥4.7μF, 1210≥4.7μF</td> </tr> <tr> <td>35V : 0805≥2.2μF, 1206≥2.2μF, 1210≥10μF</td> </tr> <tr> <td>25V : 0402≥1μF, 0603≥2.2μF, 0805≥2.2μF, 1206≥10μF, 1210≥10μF</td> </tr> <tr> <td>16V : 0402≥0.22μF, 0603≥1μF, 0805≥2.2μF, 1206≥10μF, 1210≥47μF</td> </tr> <tr> <td>10V : 0402≥0.47μF, 0603≥0.47μF, 0805≥2.2μF, 1206≥4.7μF, 1210≥47μF</td> </tr> </tbody> </table> Class II (X7R/X7S) for 1.3~1.5Vdc test <table border="1" data-bbox="746 1697 1487 1944"> <thead> <tr> <th>Rated voltage</th> <th>I.R.</th> </tr> </thead> <tbody> <tr> <td>100V : All X7R/X7S</td> <td rowspan="6">≥1GΩ or RxC≥10Ω-F, whichever is smaller</td> </tr> <tr> <td>50V : 0402>0.01μF, 0603≥1μF, 0805≥1μF, 1206≥4.7μF, 1210≥4.7μF</td> </tr> <tr> <td>35V : 0805≥2.2μF, 1206≥2.2μF, 1210≥10μF</td> </tr> <tr> <td>25V : 0402≥1μF, 0603≥2.2μF, 0805≥2.2μF, 1206≥10μF, 1210≥10μF</td> </tr> <tr> <td>16V : 0402≥0.22μF, 0603≥1μF, 0805≥2.2μF, 1206≥10μF, 1210≥47μF</td> </tr> <tr> <td>10V : 0402≥0.47μF, 0603≥0.47μF, 0805≥2.2μF, 1206≥4.7μF, 1210≥47μF</td> </tr> </tbody> </table>	Rated voltage	I.R.	100V : All X7R/X7S	≥500MΩ or RxC≥5Ω-F, whichever is smaller	50V : 0402>0.01μF, 0603≥1μF, 0805≥1μF, 1206≥4.7μF, 1210≥4.7μF	35V : 0805≥2.2μF, 1206≥2.2μF, 1210≥10μF	25V : 0402≥1μF, 0603≥2.2μF, 0805≥2.2μF, 1206≥10μF, 1210≥10μF	16V : 0402≥0.22μF, 0603≥1μF, 0805≥2.2μF, 1206≥10μF, 1210≥47μF	10V : 0402≥0.47μF, 0603≥0.47μF, 0805≥2.2μF, 1206≥4.7μF, 1210≥47μF	Rated voltage	I.R.	100V : All X7R/X7S	≥1GΩ or RxC≥10Ω-F, whichever is smaller	50V : 0402>0.01μF, 0603≥1μF, 0805≥1μF, 1206≥4.7μF, 1210≥4.7μF	35V : 0805≥2.2μF, 1206≥2.2μF, 1210≥10μF	25V : 0402≥1μF, 0603≥2.2μF, 0805≥2.2μF, 1206≥10μF, 1210≥10μF	16V : 0402≥0.22μF, 0603≥1μF, 0805≥2.2μF, 1206≥10μF, 1210≥47μF	10V : 0402≥0.47μF, 0603≥0.47μF, 0805≥2.2μF, 1206≥4.7μF, 1210≥47μF
Rated voltage	I.R.																				
100V : All X7R/X7S	≥500MΩ or RxC≥5Ω-F, whichever is smaller																				
50V : 0402>0.01μF, 0603≥1μF, 0805≥1μF, 1206≥4.7μF, 1210≥4.7μF																					
35V : 0805≥2.2μF, 1206≥2.2μF, 1210≥10μF																					
25V : 0402≥1μF, 0603≥2.2μF, 0805≥2.2μF, 1206≥10μF, 1210≥10μF																					
16V : 0402≥0.22μF, 0603≥1μF, 0805≥2.2μF, 1206≥10μF, 1210≥47μF																					
10V : 0402≥0.47μF, 0603≥0.47μF, 0805≥2.2μF, 1206≥4.7μF, 1210≥47μF																					
Rated voltage	I.R.																				
100V : All X7R/X7S	≥1GΩ or RxC≥10Ω-F, whichever is smaller																				
50V : 0402>0.01μF, 0603≥1μF, 0805≥1μF, 1206≥4.7μF, 1210≥4.7μF																					
35V : 0805≥2.2μF, 1206≥2.2μF, 1210≥10μF																					
25V : 0402≥1μF, 0603≥2.2μF, 0805≥2.2μF, 1206≥10μF, 1210≥10μF																					
16V : 0402≥0.22μF, 0603≥1μF, 0805≥2.2μF, 1206≥10μF, 1210≥47μF																					
10V : 0402≥0.47μF, 0603≥0.47μF, 0805≥2.2μF, 1206≥4.7μF, 1210≥47μF																					

8. RELIABILITY TEST CONDITIONS AND REQUIREMENTS

No.	AEC-Q200 Test Item	AEC-Q200 Test Condition	Requirements									
7	Operational Life MIL-STD-202 Method 108	* Test temp. : 125±3°C. * To apply voltage : Full rated voltage. * Test time : 1000 +24/-0 hrs. * Before initial measurement : Apply rated voltage for 1 hr at 125°C. Remove and let set for 24±2 hrs at room temp. * Measurement to be made after keeping at room temp. for 24±2 hrs.	* No remarkable damage. * Cap. change : C0G : Within ±3.0% or ±0.3pF, whichever is larger. X7R/X7S within ±12.5%. * D.F. value : C0G: Q≥350 for Cap.>30pF, Q≥275+2.5C for 10pF≤Cap.≤30pF, Q≥200+10C for Cap.<10pF. X7R/X7S : D.F.≤200% of initial requirement. * I.R. : ≥1GΩ or RxC≥50Ω-F, whichever is smaller. Class II (X7R/X7S) <table border="1"> <thead> <tr> <th>Rated voltage</th> <th>I.R.</th> </tr> </thead> <tbody> <tr> <td>100V : All X7R/X7S</td> <td rowspan="6">≥1GΩ or RxC≥100Ω-F, whichever is smaller</td> </tr> <tr> <td>50V : 0402>0.01μF, 0603≥1μF, 0805≥1μF, 1206≥4.7μF, 1210≥4.7μF</td> </tr> <tr> <td>35V : 0805≥2.2μF, 1206≥2.2μF, 1210≥10μF</td> </tr> <tr> <td>25V : 0402≥1μF, 0603≥2.2μF, 0805≥2.2μF, 1206≥10μF, 1210≥10μF</td> </tr> <tr> <td>16V : 0402≥0.22μF, 0603≥1μF, 0805≥2.2μF, 1206≥10μF, 1210≥47μF</td> </tr> <tr> <td>10V : 0402≥0.47μF, 0603≥0.47μF, 0805≥2.2μF, 1206≥4.7μF, 1210≥47μF</td> </tr> </tbody> </table>	Rated voltage	I.R.	100V : All X7R/X7S	≥1GΩ or RxC≥100Ω-F, whichever is smaller	50V : 0402>0.01μF, 0603≥1μF, 0805≥1μF, 1206≥4.7μF, 1210≥4.7μF	35V : 0805≥2.2μF, 1206≥2.2μF, 1210≥10μF	25V : 0402≥1μF, 0603≥2.2μF, 0805≥2.2μF, 1206≥10μF, 1210≥10μF	16V : 0402≥0.22μF, 0603≥1μF, 0805≥2.2μF, 1206≥10μF, 1210≥47μF	10V : 0402≥0.47μF, 0603≥0.47μF, 0805≥2.2μF, 1206≥4.7μF, 1210≥47μF
Rated voltage	I.R.											
100V : All X7R/X7S	≥1GΩ or RxC≥100Ω-F, whichever is smaller											
50V : 0402>0.01μF, 0603≥1μF, 0805≥1μF, 1206≥4.7μF, 1210≥4.7μF												
35V : 0805≥2.2μF, 1206≥2.2μF, 1210≥10μF												
25V : 0402≥1μF, 0603≥2.2μF, 0805≥2.2μF, 1206≥10μF, 1210≥10μF												
16V : 0402≥0.22μF, 0603≥1μF, 0805≥2.2μF, 1206≥10μF, 1210≥47μF												
10V : 0402≥0.47μF, 0603≥0.47μF, 0805≥2.2μF, 1206≥4.7μF, 1210≥47μF												
8	External Visual MIL-STD-883 Method 2009	* Visual inspection.	* No remarkable defect.									
9	Physical Dimension JESD22 Method JB-100	* Using by calipers.	* Within the specified dimensions.									
10	Resistance to Solvents MIL-STD-202 Method 215	* Temperature : 25±5°C. * Time : 3 +0.5/-0 min. * Solvent : Iso-propyl alcohol.	* No remarkable damage. * Cap. : Within the specified tolerance. * Q/D.F. value : To meet the initial requirement. * I.R. : To meet the initial requirement. Class II (X7R/X7S) <table border="1"> <thead> <tr> <th>Rated voltage</th> <th>I.R.</th> </tr> </thead> <tbody> <tr> <td>100V : All X7R/X7S</td> <td rowspan="6">≥10GΩ or RxC≥100Ω-F, whichever is smaller</td> </tr> <tr> <td>50V : 0402>0.01μF, 0603≥1μF, 0805≥1μF, 1206≥4.7μF, 1210≥4.7μF</td> </tr> <tr> <td>35V : 0805≥2.2μF, 1206≥2.2μF, 1210≥10μF</td> </tr> <tr> <td>25V : 0402≥1μF, 0603≥2.2μF, 0805≥2.2μF, 1206≥10μF, 1210≥10μF</td> </tr> <tr> <td>16V : 0402≥0.22μF, 0603≥1μF, 0805≥2.2μF, 1206≥10μF, 1210≥47μF</td> </tr> <tr> <td>10V : 0402≥0.47μF, 0603≥0.47μF, 0805≥2.2μF, 1206≥4.7μF, 1210≥47μF</td> </tr> </tbody> </table>	Rated voltage	I.R.	100V : All X7R/X7S	≥10GΩ or RxC≥100Ω-F, whichever is smaller	50V : 0402>0.01μF, 0603≥1μF, 0805≥1μF, 1206≥4.7μF, 1210≥4.7μF	35V : 0805≥2.2μF, 1206≥2.2μF, 1210≥10μF	25V : 0402≥1μF, 0603≥2.2μF, 0805≥2.2μF, 1206≥10μF, 1210≥10μF	16V : 0402≥0.22μF, 0603≥1μF, 0805≥2.2μF, 1206≥10μF, 1210≥47μF	10V : 0402≥0.47μF, 0603≥0.47μF, 0805≥2.2μF, 1206≥4.7μF, 1210≥47μF
Rated voltage	I.R.											
100V : All X7R/X7S	≥10GΩ or RxC≥100Ω-F, whichever is smaller											
50V : 0402>0.01μF, 0603≥1μF, 0805≥1μF, 1206≥4.7μF, 1210≥4.7μF												
35V : 0805≥2.2μF, 1206≥2.2μF, 1210≥10μF												
25V : 0402≥1μF, 0603≥2.2μF, 0805≥2.2μF, 1206≥10μF, 1210≥10μF												
16V : 0402≥0.22μF, 0603≥1μF, 0805≥2.2μF, 1206≥10μF, 1210≥47μF												
10V : 0402≥0.47μF, 0603≥0.47μF, 0805≥2.2μF, 1206≥4.7μF, 1210≥47μF												

8. RELIABILITY TEST CONDITIONS AND REQUIREMENTS

No.	AEC-Q200 Test Item	AEC-Q200 Test Condition	Requirements									
11	Mechanical Shock MIL-STD-202 Method 213	* Peak value : 1500g's. * Wave : 1/2 sine. * Velocity : 15.4 ft/sec. * Three shocks in each direction should be applied along 3 mutually perpendicular axes of the test specimen (18 shocks).	* No remarkable damage. * Cap. : Within the specified tolerance. * D.F. value :. To meet the initial requirement. * I.R. : $\geq 10G\Omega$ or $RxC \geq 500\Omega-F$, whichever is smaller. Class II (X7R/X7S) <table border="1" data-bbox="748 629 1485 871"> <thead> <tr> <th data-bbox="748 629 1342 663">Rated voltage</th> <th data-bbox="1342 629 1485 663">I.R.</th> </tr> </thead> <tbody> <tr> <td data-bbox="748 663 1342 696">100V : All X7R/X7S</td> <td data-bbox="1342 663 1485 696" rowspan="6"> $\geq 10G\Omega$ or $RxC \geq 100\Omega-F$, whichever is smaller </td> </tr> <tr> <td data-bbox="748 696 1342 730">50V : 0402$\geq 0.01\mu F$, 0603$\geq 1\mu F$, 0805$\geq 1\mu F$, 1206$\geq 4.7\mu F$, 1210$\geq 4.7\mu F$</td> </tr> <tr> <td data-bbox="748 730 1342 763">35V : 0805$\geq 2.2\mu F$, 1206$\geq 2.2\mu F$, 1210$\geq 10\mu F$</td> </tr> <tr> <td data-bbox="748 763 1342 797">25V : 0402$\geq 1\mu F$, 0603$\geq 2.2\mu F$, 0805$\geq 2.2\mu F$, 1206$\geq 10\mu F$, 1210$\geq 10\mu F$</td> </tr> <tr> <td data-bbox="748 797 1342 831">16V : 0402$\geq 0.22\mu F$, 0603$\geq 1\mu F$, 0805$\geq 2.2\mu F$, 1206$\geq 10\mu F$, 1210$\geq 47\mu F$</td> </tr> <tr> <td data-bbox="748 831 1342 871">10V : 0402$\geq 0.47\mu F$, 0603$\geq 0.47\mu F$, 0805$\geq 2.2\mu F$, 1206$\geq 4.7\mu F$, 1210$\geq 47\mu F$</td> </tr> </tbody> </table>	Rated voltage	I.R.	100V : All X7R/X7S	$\geq 10G\Omega$ or $RxC \geq 100\Omega-F$, whichever is smaller	50V : 0402 $\geq 0.01\mu F$, 0603 $\geq 1\mu F$, 0805 $\geq 1\mu F$, 1206 $\geq 4.7\mu F$, 1210 $\geq 4.7\mu F$	35V : 0805 $\geq 2.2\mu F$, 1206 $\geq 2.2\mu F$, 1210 $\geq 10\mu F$	25V : 0402 $\geq 1\mu F$, 0603 $\geq 2.2\mu F$, 0805 $\geq 2.2\mu F$, 1206 $\geq 10\mu F$, 1210 $\geq 10\mu F$	16V : 0402 $\geq 0.22\mu F$, 0603 $\geq 1\mu F$, 0805 $\geq 2.2\mu F$, 1206 $\geq 10\mu F$, 1210 $\geq 47\mu F$	10V : 0402 $\geq 0.47\mu F$, 0603 $\geq 0.47\mu F$, 0805 $\geq 2.2\mu F$, 1206 $\geq 4.7\mu F$, 1210 $\geq 47\mu F$
Rated voltage	I.R.											
100V : All X7R/X7S	$\geq 10G\Omega$ or $RxC \geq 100\Omega-F$, whichever is smaller											
50V : 0402 $\geq 0.01\mu F$, 0603 $\geq 1\mu F$, 0805 $\geq 1\mu F$, 1206 $\geq 4.7\mu F$, 1210 $\geq 4.7\mu F$												
35V : 0805 $\geq 2.2\mu F$, 1206 $\geq 2.2\mu F$, 1210 $\geq 10\mu F$												
25V : 0402 $\geq 1\mu F$, 0603 $\geq 2.2\mu F$, 0805 $\geq 2.2\mu F$, 1206 $\geq 10\mu F$, 1210 $\geq 10\mu F$												
16V : 0402 $\geq 0.22\mu F$, 0603 $\geq 1\mu F$, 0805 $\geq 2.2\mu F$, 1206 $\geq 10\mu F$, 1210 $\geq 47\mu F$												
10V : 0402 $\geq 0.47\mu F$, 0603 $\geq 0.47\mu F$, 0805 $\geq 2.2\mu F$, 1206 $\geq 4.7\mu F$, 1210 $\geq 47\mu F$												
12	Vibration MIL-STD-202 Method 204	* Vibration frequency : 10~2000 Hz/min. (5g's for 20 min.). * Total amplitude : 1.5mm. * 12 cycles each of 3 orientations (36 times).	* No remarkable damage. * Cap. : Within the specified tolerance. * D.F. value :. To meet the initial requirement. * I.R. : $\geq 10G\Omega$ or $RxC \geq 500\Omega-F$, whichever is smaller. Class II (X7R/X7S) <table border="1" data-bbox="748 1301 1485 1543"> <thead> <tr> <th data-bbox="748 1301 1342 1335">Rated voltage</th> <th data-bbox="1342 1301 1485 1335">I.R.</th> </tr> </thead> <tbody> <tr> <td data-bbox="748 1335 1342 1368">100V : All X7R/X7S</td> <td data-bbox="1342 1335 1485 1368" rowspan="6"> $\geq 10G\Omega$ or $RxC \geq 100\Omega-F$, whichever is smaller </td> </tr> <tr> <td data-bbox="748 1368 1342 1402">50V : 0402$\geq 0.01\mu F$, 0603$\geq 1\mu F$, 0805$\geq 1\mu F$, 1206$\geq 4.7\mu F$, 1210$\geq 4.7\mu F$</td> </tr> <tr> <td data-bbox="748 1402 1342 1435">35V : 0805$\geq 2.2\mu F$, 1206$\geq 2.2\mu F$, 1210$\geq 10\mu F$</td> </tr> <tr> <td data-bbox="748 1435 1342 1469">25V : 0402$\geq 1\mu F$, 0603$\geq 2.2\mu F$, 0805$\geq 2.2\mu F$, 1206$\geq 10\mu F$, 1210$\geq 10\mu F$</td> </tr> <tr> <td data-bbox="748 1469 1342 1503">16V : 0402$\geq 0.22\mu F$, 0603$\geq 1\mu F$, 0805$\geq 2.2\mu F$, 1206$\geq 10\mu F$, 1210$\geq 47\mu F$</td> </tr> <tr> <td data-bbox="748 1503 1342 1543">10V : 0402$\geq 0.47\mu F$, 0603$\geq 0.47\mu F$, 0805$\geq 2.2\mu F$, 1206$\geq 4.7\mu F$, 1210$\geq 47\mu F$</td> </tr> </tbody> </table>	Rated voltage	I.R.	100V : All X7R/X7S	$\geq 10G\Omega$ or $RxC \geq 100\Omega-F$, whichever is smaller	50V : 0402 $\geq 0.01\mu F$, 0603 $\geq 1\mu F$, 0805 $\geq 1\mu F$, 1206 $\geq 4.7\mu F$, 1210 $\geq 4.7\mu F$	35V : 0805 $\geq 2.2\mu F$, 1206 $\geq 2.2\mu F$, 1210 $\geq 10\mu F$	25V : 0402 $\geq 1\mu F$, 0603 $\geq 2.2\mu F$, 0805 $\geq 2.2\mu F$, 1206 $\geq 10\mu F$, 1210 $\geq 10\mu F$	16V : 0402 $\geq 0.22\mu F$, 0603 $\geq 1\mu F$, 0805 $\geq 2.2\mu F$, 1206 $\geq 10\mu F$, 1210 $\geq 47\mu F$	10V : 0402 $\geq 0.47\mu F$, 0603 $\geq 0.47\mu F$, 0805 $\geq 2.2\mu F$, 1206 $\geq 4.7\mu F$, 1210 $\geq 47\mu F$
Rated voltage	I.R.											
100V : All X7R/X7S	$\geq 10G\Omega$ or $RxC \geq 100\Omega-F$, whichever is smaller											
50V : 0402 $\geq 0.01\mu F$, 0603 $\geq 1\mu F$, 0805 $\geq 1\mu F$, 1206 $\geq 4.7\mu F$, 1210 $\geq 4.7\mu F$												
35V : 0805 $\geq 2.2\mu F$, 1206 $\geq 2.2\mu F$, 1210 $\geq 10\mu F$												
25V : 0402 $\geq 1\mu F$, 0603 $\geq 2.2\mu F$, 0805 $\geq 2.2\mu F$, 1206 $\geq 10\mu F$, 1210 $\geq 10\mu F$												
16V : 0402 $\geq 0.22\mu F$, 0603 $\geq 1\mu F$, 0805 $\geq 2.2\mu F$, 1206 $\geq 10\mu F$, 1210 $\geq 47\mu F$												
10V : 0402 $\geq 0.47\mu F$, 0603 $\geq 0.47\mu F$, 0805 $\geq 2.2\mu F$, 1206 $\geq 4.7\mu F$, 1210 $\geq 47\mu F$												

8. RELIABILITY TEST CONDITIONS AND REQUIREMENTS

No.	AEC-Q200 Test Item	AEC-Q200 Test Condition	Requirements																		
13	Resistance to Soldering Heat MIL-STD-202 Method 210	<p>* Solder temperature : 260±5°C. * Dipping time : 10±1 sec. * Before initial measurement : Perform 150 +0/-10°C for 1 hr and then set for 24±2 hrs at room temp. * Measurement to be made after keeping at room temp. for 24±2 hrs.</p>	<p>* No remarkable damage. * Cap. change : X7R/X7S within ±7.5%. * D.F. value : C0G : Within ±2.5% or ±0.25pF, whichever is larger. X7R/X7S : D.F.≤100% of initial requirement. * I.R. : ≥10GΩ or RxC≥500Ω-F, whichever is smaller. Class II (X7R/X7S)</p> <table border="1"> <thead> <tr> <th>Rated voltage</th> <th>I.R.</th> </tr> </thead> <tbody> <tr> <td>100V : All X7R/X7S</td> <td rowspan="6">≥10GΩ or RxC≥100Ω-F, whichever is smaller</td> </tr> <tr> <td>50V : 0402>0.01μF, 0603≥1μF, 0805≥1μF, 1206≥4.7μF, 1210≥4.7μF</td> </tr> <tr> <td>35V : 0805≥2.2μF, 1206≥2.2μF, 1210≥10μF</td> </tr> <tr> <td>25V : 0402≥1μF, 0603≥2.2μF, 0805≥2.2μF, 1206≥10μF, 1210≥10μF</td> </tr> <tr> <td>16V : 0402≥0.22μF, 0603≥1μF, 0805≥2.2μF, 1206≥10μF, 1210≥47μF</td> </tr> <tr> <td>10V : 0402≥0.47μF, 0603≥0.47μF, 0805≥2.2μF, 1206≥4.7μF, 1210≥47μF</td> </tr> </tbody> </table>	Rated voltage	I.R.	100V : All X7R/X7S	≥10GΩ or RxC≥100Ω-F, whichever is smaller	50V : 0402>0.01μF, 0603≥1μF, 0805≥1μF, 1206≥4.7μF, 1210≥4.7μF	35V : 0805≥2.2μF, 1206≥2.2μF, 1210≥10μF	25V : 0402≥1μF, 0603≥2.2μF, 0805≥2.2μF, 1206≥10μF, 1210≥10μF	16V : 0402≥0.22μF, 0603≥1μF, 0805≥2.2μF, 1206≥10μF, 1210≥47μF	10V : 0402≥0.47μF, 0603≥0.47μF, 0805≥2.2μF, 1206≥4.7μF, 1210≥47μF									
Rated voltage	I.R.																				
100V : All X7R/X7S	≥10GΩ or RxC≥100Ω-F, whichever is smaller																				
50V : 0402>0.01μF, 0603≥1μF, 0805≥1μF, 1206≥4.7μF, 1210≥4.7μF																					
35V : 0805≥2.2μF, 1206≥2.2μF, 1210≥10μF																					
25V : 0402≥1μF, 0603≥2.2μF, 0805≥2.2μF, 1206≥10μF, 1210≥10μF																					
16V : 0402≥0.22μF, 0603≥1μF, 0805≥2.2μF, 1206≥10μF, 1210≥47μF																					
10V : 0402≥0.47μF, 0603≥0.47μF, 0805≥2.2μF, 1206≥4.7μF, 1210≥47μF																					
14	Thermal Shock MIL-STD-202 Method 107	<p>* Conduct 300 cycles according to the temperatures and time.</p> <table border="1"> <thead> <tr> <th>Step</th> <th>Temp.(°C)</th> <th>Time(min.)</th> </tr> </thead> <tbody> <tr> <td>1</td> <td>-55°C +0/-3</td> <td>15±3</td> </tr> <tr> <td>2</td> <td>+125°C +3/-0</td> <td>15±3</td> </tr> </tbody> </table> <p>* Max. transfer time : 20 sec. * Before initial measurement : Perform 150 +0/-10°C for 1 hr and then set for 24±2 hrs at room temp. * Measurement to be made after keeping at room temp. for 24±2 hrs.</p>	Step	Temp.(°C)	Time(min.)	1	-55°C +0/-3	15±3	2	+125°C +3/-0	15±3	<p>* No remarkable damage. * Cap. change : C0G : Within ±2.5% or ±0.25pF, whichever is larger X7R/X7S within ±10.0%. * D.F. value : C0G : To meet the initial requirement X7R/X7S : D.F.≤200% of initial requirement. * I.R. : ≥10GΩ or RxC≥500Ω-F, whichever is smaller. Class II (X7R/X7S)</p> <table border="1"> <thead> <tr> <th>Rated voltage</th> <th>I.R.</th> </tr> </thead> <tbody> <tr> <td>100V : All X7R/X7S</td> <td rowspan="6">≥1GΩ or RxC≥10Ω-F, whichever is smaller</td> </tr> <tr> <td>50V : 0402>0.01μF, 0603≥1μF, 0805≥1μF, 1206≥4.7μF, 1210≥4.7μF</td> </tr> <tr> <td>35V : 0805≥2.2μF, 1206≥2.2μF, 1210≥10μF</td> </tr> <tr> <td>25V : 0402≥1μF, 0603≥2.2μF, 0805≥2.2μF, 1206≥10μF, 1210≥10μF</td> </tr> <tr> <td>16V : 0402≥0.22μF, 0603≥1μF, 0805≥2.2μF, 1206≥10μF, 1210≥47μF</td> </tr> <tr> <td>10V : 0402≥0.47μF, 0603≥0.47μF, 0805≥2.2μF, 1206≥4.7μF, 1210≥47μF</td> </tr> </tbody> </table>	Rated voltage	I.R.	100V : All X7R/X7S	≥1GΩ or RxC≥10Ω-F, whichever is smaller	50V : 0402>0.01μF, 0603≥1μF, 0805≥1μF, 1206≥4.7μF, 1210≥4.7μF	35V : 0805≥2.2μF, 1206≥2.2μF, 1210≥10μF	25V : 0402≥1μF, 0603≥2.2μF, 0805≥2.2μF, 1206≥10μF, 1210≥10μF	16V : 0402≥0.22μF, 0603≥1μF, 0805≥2.2μF, 1206≥10μF, 1210≥47μF	10V : 0402≥0.47μF, 0603≥0.47μF, 0805≥2.2μF, 1206≥4.7μF, 1210≥47μF
Step	Temp.(°C)	Time(min.)																			
1	-55°C +0/-3	15±3																			
2	+125°C +3/-0	15±3																			
Rated voltage	I.R.																				
100V : All X7R/X7S	≥1GΩ or RxC≥10Ω-F, whichever is smaller																				
50V : 0402>0.01μF, 0603≥1μF, 0805≥1μF, 1206≥4.7μF, 1210≥4.7μF																					
35V : 0805≥2.2μF, 1206≥2.2μF, 1210≥10μF																					
25V : 0402≥1μF, 0603≥2.2μF, 0805≥2.2μF, 1206≥10μF, 1210≥10μF																					
16V : 0402≥0.22μF, 0603≥1μF, 0805≥2.2μF, 1206≥10μF, 1210≥47μF																					
10V : 0402≥0.47μF, 0603≥0.47μF, 0805≥2.2μF, 1206≥4.7μF, 1210≥47μF																					

8. RELIABILITY TEST CONDITIONS AND REQUIREMENTS

No.	AEC-Q200 Test Item	AEC-Q200 Test Condition	Requirements									
15	ESD AEC-Q200-002	* Per AEC-Q200-002.	* No remarkable damage. * Cap. : Within the specified tolerance. * D.F. value : To meet the initial requirement. X7R/X7S : D.F.≤100% of initial requirement. * I.R. : To meet the initial requirement. Class II (X7R/X7S) <table border="1" data-bbox="746 651 1481 891"> <thead> <tr> <th data-bbox="746 651 1342 685">Rated voltage</th> <th data-bbox="1342 651 1481 685">I.R.</th> </tr> </thead> <tbody> <tr> <td data-bbox="746 685 1342 719">100V : All X7R/X7S</td> <td data-bbox="1342 685 1481 719" rowspan="6">≥10GΩ or RxC≥100Ω-F, whichever is smaller</td> </tr> <tr> <td data-bbox="746 719 1342 752">50V : 0402>0.01μF, 0603≥1μF, 0805≥1μF, 1206≥4.7μF, 1210≥4.7μF</td> </tr> <tr> <td data-bbox="746 752 1342 786">35V : 0805≥2.2μF, 1206≥2.2μF, 1210≥10μF</td> </tr> <tr> <td data-bbox="746 786 1342 819">25V : 0402≥1μF, 0603≥2.2μF, 0805≥2.2μF, 1206≥10μF, 1210≥10μF</td> </tr> <tr> <td data-bbox="746 819 1342 853">16V : 0402≥0.22μF, 0603≥1μF, 0805≥2.2μF, 1206≥10μF, 1210≥47μF</td> </tr> <tr> <td data-bbox="746 853 1342 891">10V : 0402≥0.47μF, 0603≥0.47μF, 0805≥2.2μF, 1206≥4.7μF, 1210≥47μF</td> </tr> </tbody> </table>	Rated voltage	I.R.	100V : All X7R/X7S	≥10GΩ or RxC≥100Ω-F, whichever is smaller	50V : 0402>0.01μF, 0603≥1μF, 0805≥1μF, 1206≥4.7μF, 1210≥4.7μF	35V : 0805≥2.2μF, 1206≥2.2μF, 1210≥10μF	25V : 0402≥1μF, 0603≥2.2μF, 0805≥2.2μF, 1206≥10μF, 1210≥10μF	16V : 0402≥0.22μF, 0603≥1μF, 0805≥2.2μF, 1206≥10μF, 1210≥47μF	10V : 0402≥0.47μF, 0603≥0.47μF, 0805≥2.2μF, 1206≥4.7μF, 1210≥47μF
Rated voltage	I.R.											
100V : All X7R/X7S	≥10GΩ or RxC≥100Ω-F, whichever is smaller											
50V : 0402>0.01μF, 0603≥1μF, 0805≥1μF, 1206≥4.7μF, 1210≥4.7μF												
35V : 0805≥2.2μF, 1206≥2.2μF, 1210≥10μF												
25V : 0402≥1μF, 0603≥2.2μF, 0805≥2.2μF, 1206≥10μF, 1210≥10μF												
16V : 0402≥0.22μF, 0603≥1μF, 0805≥2.2μF, 1206≥10μF, 1210≥47μF												
10V : 0402≥0.47μF, 0603≥0.47μF, 0805≥2.2μF, 1206≥4.7μF, 1210≥47μF												
16	Solderability J-STD-002 JESD22-B102E	* Condition A Un-mounted chips 4hrs / 155°C*dry then completely immersed for 5±0.5 sec in solder bath at 245±5°C. * Condition B Un-mounted chips steam 8 hrs then completely immersed for 10±1sec in solder bath at 220 +5/-0°C. * Condition C Un-mounted chips steam 8 hrs then completely immersed for 10±1 sec. in solder bath at 260 +0/-5°C.	* All terminations shall exhibit a continuous solder coating free from defects from a minimum of 95% of the critical surface area of any individual termination.									

8. RELIABILITY TEST CONDITIONS AND REQUIREMENTS

No.	AEC-Q200 Test Item	AEC-Q200 Test Condition	Requirements																																												
17	Electrical Characterization	<p>* Capacitance. * D.F. (Dissipation Factor). X7R/X7S : Cap.≤10μF : 1.0±0.2Vrms, 1KHz±10%. Cap.>10μF : 0.5±0.2Vrms, 120Hz±20%.</p>	<p>* Capacitance within the specified tolerance. * D.F. value : To meet the initial requirement. X7R/X7S :</p> <table border="1"> <thead> <tr> <th>Rated</th> <th>D.F.≤</th> <th colspan="2">Exception of D.F.≤</th> </tr> </thead> <tbody> <tr> <td rowspan="3">≥100V</td> <td rowspan="3">≤2.5%</td> <td>≤3%</td> <td>1206≥0.47μF, 1812≥4.7μF, 1825≥4.7μF, 2220≥4.7μF, 2225≥4.7μF</td> </tr> <tr> <td>≤5%</td> <td>0805>0.1μF, 0603≥0.068μF, 1206>1μF, 1210≥2.2μF</td> </tr> <tr> <td>≤10%</td> <td>0805>0.22μF, 1210≥3.3μF</td> </tr> <tr> <td rowspan="3">50V</td> <td rowspan="3">≤2.5%</td> <td>≤3%</td> <td>0201(50V), 0603≥0.047μF, 0805≥0.18μF, 1206≥0.47μF, 1210≥3.3μF, 1812≥4.7μF, 1825≥4.7μF, 2220≥4.7μF, 2225≥4.7μF</td> </tr> <tr> <td>≤5%</td> <td>0201≥0.01μF, 1210≥4.7μF</td> </tr> <tr> <td>≤10%</td> <td>0402≥0.1μF, 0603>0.1μF, 0805≥1μF, 1206≥2.2μF, 1210≥10μF</td> </tr> <tr> <td>35V</td> <td>≤3.5%</td> <td>≤10%</td> <td>0603≥1μF, 0805≥2.2μF, 1206≥2.2μF, 1210≥10μF</td> </tr> <tr> <td rowspan="3">25V</td> <td rowspan="3">≤3.5%</td> <td>≤5%</td> <td>0201≥0.01μF, 0805≥1μF, 1210≥10μF</td> </tr> <tr> <td>≤7%</td> <td>0603≥0.33μF, 1206≥4.7μF</td> </tr> <tr> <td>≤10%</td> <td>0201≥0.1μF, 0402≥0.10μF, 0603≥0.47μF, 0805≥2.2μF, 1206≥6.8μF, 1210≥22μF</td> </tr> <tr> <td rowspan="2">16V</td> <td rowspan="2">≤3.5%</td> <td>≤12.5%</td> <td>0402≥0.47μF</td> </tr> <tr> <td>≤5%</td> <td>0201≥0.01μF, 0402≥0.033μF, 0603≥0.15μF, 0805≥0.68μF, 1206≥2.2μF, 1210≥4.7μF</td> </tr> <tr> <td rowspan="2">10V</td> <td rowspan="2">≤5%</td> <td>≤10%</td> <td>0201≥0.1μF(0201/X7R/X7S≥0.022μF), 0402≥0.22μF, 0603≥0.68μF, 0805≥2.2μF, 1206≥4.7μF, 1210≥22μF</td> </tr> <tr> <td>≤15%</td> <td>0201≥0.012μF, 0402≥0.33μF(0402/X7R/X7S≥0.22μF), 0603≥0.33μF, 0805≥2.2μF, 1206≥2.2μF, 1210≥22μF</td> </tr> </tbody> </table>	Rated	D.F.≤	Exception of D.F.≤		≥100V	≤2.5%	≤3%	1206≥0.47μF, 1812≥4.7μF, 1825≥4.7μF, 2220≥4.7μF, 2225≥4.7μF	≤5%	0805>0.1μF, 0603≥0.068μF, 1206>1μF, 1210≥2.2μF	≤10%	0805>0.22μF, 1210≥3.3μF	50V	≤2.5%	≤3%	0201(50V), 0603≥0.047μF, 0805≥0.18μF, 1206≥0.47μF, 1210≥3.3μF, 1812≥4.7μF, 1825≥4.7μF, 2220≥4.7μF, 2225≥4.7μF	≤5%	0201≥0.01μF, 1210≥4.7μF	≤10%	0402≥0.1μF, 0603>0.1μF, 0805≥1μF, 1206≥2.2μF, 1210≥10μF	35V	≤3.5%	≤10%	0603≥1μF, 0805≥2.2μF, 1206≥2.2μF, 1210≥10μF	25V	≤3.5%	≤5%	0201≥0.01μF, 0805≥1μF, 1210≥10μF	≤7%	0603≥0.33μF, 1206≥4.7μF	≤10%	0201≥0.1μF, 0402≥0.10μF, 0603≥0.47μF, 0805≥2.2μF, 1206≥6.8μF, 1210≥22μF	16V	≤3.5%	≤12.5%	0402≥0.47μF	≤5%	0201≥0.01μF, 0402≥0.033μF, 0603≥0.15μF, 0805≥0.68μF, 1206≥2.2μF, 1210≥4.7μF	10V	≤5%	≤10%	0201≥0.1μF(0201/X7R/X7S≥0.022μF), 0402≥0.22μF, 0603≥0.68μF, 0805≥2.2μF, 1206≥4.7μF, 1210≥22μF	≤15%	0201≥0.012μF, 0402≥0.33μF(0402/X7R/X7S≥0.22μF), 0603≥0.33μF, 0805≥2.2μF, 1206≥2.2μF, 1210≥22μF
		Rated	D.F.≤	Exception of D.F.≤																																											
		≥100V	≤2.5%	≤3%	1206≥0.47μF, 1812≥4.7μF, 1825≥4.7μF, 2220≥4.7μF, 2225≥4.7μF																																										
≤5%	0805>0.1μF, 0603≥0.068μF, 1206>1μF, 1210≥2.2μF																																														
≤10%	0805>0.22μF, 1210≥3.3μF																																														
50V	≤2.5%	≤3%	0201(50V), 0603≥0.047μF, 0805≥0.18μF, 1206≥0.47μF, 1210≥3.3μF, 1812≥4.7μF, 1825≥4.7μF, 2220≥4.7μF, 2225≥4.7μF																																												
		≤5%	0201≥0.01μF, 1210≥4.7μF																																												
		≤10%	0402≥0.1μF, 0603>0.1μF, 0805≥1μF, 1206≥2.2μF, 1210≥10μF																																												
35V	≤3.5%	≤10%	0603≥1μF, 0805≥2.2μF, 1206≥2.2μF, 1210≥10μF																																												
25V	≤3.5%	≤5%	0201≥0.01μF, 0805≥1μF, 1210≥10μF																																												
		≤7%	0603≥0.33μF, 1206≥4.7μF																																												
		≤10%	0201≥0.1μF, 0402≥0.10μF, 0603≥0.47μF, 0805≥2.2μF, 1206≥6.8μF, 1210≥22μF																																												
16V	≤3.5%	≤12.5%	0402≥0.47μF																																												
		≤5%	0201≥0.01μF, 0402≥0.033μF, 0603≥0.15μF, 0805≥0.68μF, 1206≥2.2μF, 1210≥4.7μF																																												
10V	≤5%	≤10%	0201≥0.1μF(0201/X7R/X7S≥0.022μF), 0402≥0.22μF, 0603≥0.68μF, 0805≥2.2μF, 1206≥4.7μF, 1210≥22μF																																												
		≤15%	0201≥0.012μF, 0402≥0.33μF(0402/X7R/X7S≥0.22μF), 0603≥0.33μF, 0805≥2.2μF, 1206≥2.2μF, 1210≥22μF																																												
		<p>* Insulation Resistance.</p> <table border="1"> <thead> <tr> <th>Rated Vol.(V)</th> <th>Apply Voltage</th> <th>Charge Time</th> </tr> </thead> <tbody> <tr> <td>≤100</td> <td>1 times of U_R</td> <td>Max. 120 sec.</td> </tr> <tr> <td>200≤V≤500</td> <td>1 times of U_R</td> <td>60 sec.</td> </tr> <tr> <td>>500</td> <td>500Vdc</td> <td>60 sec.</td> </tr> </tbody> </table>	Rated Vol.(V)	Apply Voltage	Charge Time	≤100	1 times of U _R	Max. 120 sec.	200≤V≤500	1 times of U _R	60 sec.	>500	500Vdc	60 sec.	<p>* I.R. : ≥10GΩ or RxC≥500Ω-F, whichever is smaller. Class II (X7R/X7S)</p> <table border="1"> <thead> <tr> <th>Rated voltage</th> <th>I.R.</th> </tr> </thead> <tbody> <tr> <td>100V : All X7R/X7S</td> <td rowspan="6">≥10GΩ or RxC≥100Ω-F, whichever is smaller</td> </tr> <tr> <td>50V : 0402>0.01μF, 0603≥1μF, 0805≥1μF, 1206≥4.7μF, 1210≥4.7μF</td> </tr> <tr> <td>35V : 0805≥2.2μF, 1206≥2.2μF, 1210≥10μF</td> </tr> <tr> <td>25V : 0402≥1μF, 0603≥2.2μF, 0805≥2.2μF, 1206≥10μF, 1210≥10μF</td> </tr> <tr> <td>16V : 0402≥0.22μF, 0603≥1μF, 0805≥2.2μF, 1206≥10μF, 1210≥47μF</td> </tr> <tr> <td>10V : 0402≥0.47μF, 0603≥0.47μF, 0805≥2.2μF, 1206≥4.7μF, 1210≥47μF</td> </tr> </tbody> </table>	Rated voltage	I.R.	100V : All X7R/X7S	≥10GΩ or RxC≥100Ω-F, whichever is smaller	50V : 0402>0.01μF, 0603≥1μF, 0805≥1μF, 1206≥4.7μF, 1210≥4.7μF	35V : 0805≥2.2μF, 1206≥2.2μF, 1210≥10μF	25V : 0402≥1μF, 0603≥2.2μF, 0805≥2.2μF, 1206≥10μF, 1210≥10μF	16V : 0402≥0.22μF, 0603≥1μF, 0805≥2.2μF, 1206≥10μF, 1210≥47μF	10V : 0402≥0.47μF, 0603≥0.47μF, 0805≥2.2μF, 1206≥4.7μF, 1210≥47μF																							
Rated Vol.(V)	Apply Voltage	Charge Time																																													
≤100	1 times of U _R	Max. 120 sec.																																													
200≤V≤500	1 times of U _R	60 sec.																																													
>500	500Vdc	60 sec.																																													
Rated voltage	I.R.																																														
100V : All X7R/X7S	≥10GΩ or RxC≥100Ω-F, whichever is smaller																																														
50V : 0402>0.01μF, 0603≥1μF, 0805≥1μF, 1206≥4.7μF, 1210≥4.7μF																																															
35V : 0805≥2.2μF, 1206≥2.2μF, 1210≥10μF																																															
25V : 0402≥1μF, 0603≥2.2μF, 0805≥2.2μF, 1206≥10μF, 1210≥10μF																																															
16V : 0402≥0.22μF, 0603≥1μF, 0805≥2.2μF, 1206≥10μF, 1210≥47μF																																															
10V : 0402≥0.47μF, 0603≥0.47μF, 0805≥2.2μF, 1206≥4.7μF, 1210≥47μF																																															
		<p>* Dielectric Strength.</p> <table border="1"> <thead> <tr> <th>Rated Voltage</th> <th>Condition</th> </tr> </thead> <tbody> <tr> <td>≤100</td> <td>2.5 times of U_R</td> </tr> <tr> <td>100<V≤250</td> <td>2.0 times of U_R</td> </tr> <tr> <td>250<V≤500</td> <td>1.5 times of U_R</td> </tr> <tr> <td>630≤V≤3000V</td> <td>1.2 times of U_R</td> </tr> <tr> <td>3000<V<5000V</td> <td>1.1 times of U_R</td> </tr> <tr> <td>≥5000V</td> <td>1.0 times of U_R</td> </tr> </tbody> </table> <p>* Duration 1~5 sec, charge and discharge current less than 50mA. * Test in insulating fluid for rated voltage ≥1KV products.</p>	Rated Voltage	Condition	≤100	2.5 times of U _R	100<V≤250	2.0 times of U _R	250<V≤500	1.5 times of U _R	630≤V≤3000V	1.2 times of U _R	3000<V<5000V	1.1 times of U _R	≥5000V	1.0 times of U _R	<p>* No evidence of damage or flash over during test.</p>																														
Rated Voltage	Condition																																														
≤100	2.5 times of U _R																																														
100<V≤250	2.0 times of U _R																																														
250<V≤500	1.5 times of U _R																																														
630≤V≤3000V	1.2 times of U _R																																														
3000<V<5000V	1.1 times of U _R																																														
≥5000V	1.0 times of U _R																																														
		<p>* Temperature Coefficient (With no electrical load) Operation temperature : -55~125°C at 25°C.</p>	<p>* Capacitance change : C0G : Within ±30ppm/°C. X7R within ±15%. X7S within ±22%.</p>																																												

8. RELIABILITY TEST CONDITIONS AND REQUIREMENTS

No.	AEC-Q200 Test Item	AEC-Q200 Test Condition	Requirements
18	Board Flex AEC-Q200-005	<ul style="list-style-type: none"> * The middle part of substrate shall be pressurized by means of the pressurizing rod at a rate of about 1 mm per second until the deflection becomes 3mm and then the pressure shall be maintained for 60±1 sec. * Measurement to be made after keeping at room temp. for 24±2 hrs. 	<ul style="list-style-type: none"> * No remarkable damage. * Capacitance within the specified tolerance. * D.F. : ≤100% of initial requirement. * I.R. : ≥100% of initial requirement. (This capacitance change means the change of capacitance under specified flexure of substrate from the capacitance measured before the test)
19	Terminal Strength AEC-Q200-006	<ul style="list-style-type: none"> * Pressurizing force : 2N (0402), 5N(0603), 10N(0805), 17.7N(≥1206). * Test time : 60±1 sec. 	<ul style="list-style-type: none"> * No remarkable damage or removal of the terminations. * Capacitance within the specified tolerance. * Q/D.F. value : To meet the initial requirement. * I.R. : To meet the initial requirement.
20	Beam Load Test AEC-Q200-003	<ul style="list-style-type: none"> * Break strength test. * Beam speed : 2.5±0.25 mm/sec. 	<ul style="list-style-type: none"> * The chip endure following force : Chip length ≤2.5mm : Thickness >0.5mm (20N), ≤0.5mm (8N). Chip length ≥3.2mm : Thickness ≥1.25mm (54.5N), <1.25mm (15N).

9. PACKAGE DIMENSION AND QUANTITY

Size	Thickness (mm)	Paper tape		Plastic tape	
		7" reel	13" reel	7" reel	13" reel
0402 (1005)	0.50±0.20	10k	-	-	-
0603(1608)	0.50±0.10	4k	-	-	-
	0.80±0.07	4k	15k	-	-
	0.80 +0.15/-0.10	4k	15k	-	-
0805(2012)	0.50±0.10	4k	15k	-	-
	0.60±0.10	4k	15k	-	-
	0.80±0.10	4k	15k	-	-
	0.85±0.10	4k	15k	-	-
	1.25±0.10	-	-	3k	10k
	1.25±0.20	-	-	3k	10k
1206(3216)	0.80±0.10	4k	15k	-	-
	0.85±0.10	4k	15k	-	-
	0.95±0.10	-	-	3k	10k
	1.15±0.15	-	-	3k	10k
	1.25±0.10	-	-	3k	10k
	1.60±0.20	-	-	2k	10k
	1.60 +0.30/-0.10	-	-	2k	9k
1210(3225)	0.85±0.10	-	-	3k	10k
	0.95±0.10	-	-	3k	10k
	1.25±0.10	-	-	3k	10k
	1.60±0.20	-	-	2k	-
	2.00±0.20	-	-	1k	6k
	2.50±0.30	-	-	1k	6k
1808(4520)	1.25±0.10	-	-	2k	10k
	1.60±0.20	-	-	2k	8k
	2.00±0.20	-	-	1k	6k
1812(4532)	1.25±0.10	-	-	1k	5k
	1.60±0.20	-	-	1k	-
	2.00±0.20	-	-	1k	-
	2.50±0.30	-	-	0.5k	3k
	2.80±0.30	-	-	0.5k	-
2220(5750)	1.60±0.20	-	-	1k	-
	2.00±0.20	-	-	1k	-
	2.50±0.30	-	-	0.5k	-
	2.80±0.30	-	-	0.5k	-

Unit : pcs

9. PACKAGE DIMENSION AND QUANTITY

9.1. EMBOSSED TAPE DIMENSIONS

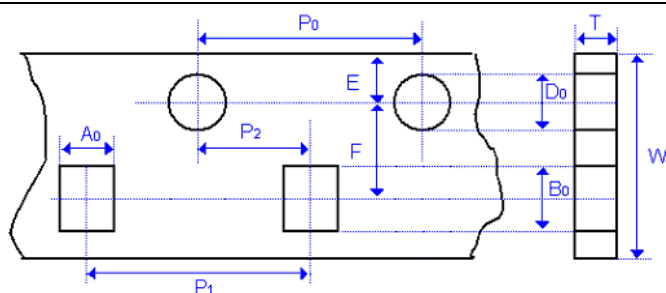

Fig. 9.1 The dimension of paper tape

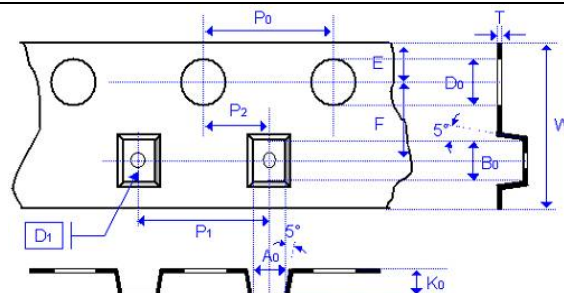

Fig. 9.2 The dimension of plastic tape

Size	0402	0603		0805	
Chip Thickness	0.50±0.20	0.80±0.07	0.80 +0.15/-0.1	0.80±0.10	1.25±0.10 1.25±0.20
A ₀	0.7+/-0.20	1.00 +0.05/-0.1	1.02 +0.05/-0.1	1.50±0.10	<1.65
B ₀	1.20±0.20	1.80±0.10	1.80±0.10	2.30±0.10	<2.40
T	≤0.80	0.95±0.05	0.97±0.05	0.95±0.05	0.23±0.05
K ₀	-	-	-	-	<2.50
W	8.00±0.30	8.00±0.10	8.00±0.10	8.00±0.10	8.00±0.10
P ₀	4.00±0.10	4.00±0.10	4.00±0.10	4.00±0.10	4.00±0.10
10xP ₀	40.00±0.10	40.00±0.20	40.00±0.20	40.00±0.20	40.00±0.20
P ₁	2.00±0.05	4.00±0.10	4.00±0.10	4.00±0.10	4.00±0.10
P ₂	2.00±0.05	2.00±0.05	2.00±0.05	2.00±0.05	2.00±0.05
D ₀	1.50+0.1/-0	1.55±0.05	1.55±0.05	1.55±0.05	1.50 +0.10/-0
D ₁	-	-	-	-	1.00±0.10
E	1.75±0.10	1.75±0.05	1.75±0.05	1.75±0.05	1.75±0.10
F	3.50±0.05	3.50±0.05	3.50±0.05	3.50±0.05	3.50±0.05
Unit :	mm	mm	mm	mm	mm

Size	1206			1210		1812	
Chip Thickness	0.80±0.10	0.95±0.10 1.25±0.10	1.60±0.20 1.60+0.3/-0/1	0.95±0.10 1.25±0.10 1.60±0.20 2.00±0.20	2.50±0.30	1.25±0.10 1.60±0.20 2.00±0.20	2.50±0.30 2.80±0.30
A ₀	2.00±0.10	<2.00	<2.00	<3.05	<3.10	<3.90	<3.90
B ₀	3.50±0.10	<3.60	<3.70	<3.80	<4.00	<5.30	<5.30
T	0.95±0.05	0.23±0.05	0.23±0.05	0.23±0.05	0.23±0.05	0.25±0.05	0.25±0.05
K ₀	-	<2.50	<2.50	<2.50	<3.50	<2.50	<3.00
W	8.00±0.10	8.00±0.10	8.00±0.10	8.00±0.10	8.00±0.10	12.00±0.20	12.00±0.20
P ₀	4.00±0.10	4.00±0.10	4.00±0.10	4.00±0.100	4.00±0.10	4.00±0.10	4.00±0.10
10xP ₀	40.00±0.20	40.00±0.20	40.00±0.20	40.00±0.20	40.00±0.20	40.00±0.20	40.00±0.20
P ₁	4.00±0.10	4.00±0.10	4.00±0.10	4.00±0.10	4.00±0.10	8.00±0.10	8.00±0.10
P ₂	2.00±0.05	2.00±0.05	2.00±0.05	2.00±0.05	2.00±0.05	2.00±0.05	2.00±0.05
D ₀	1.55±0.05	1.50 +0.10/-0	1.50 +0.10/-0	1.50 +0.10/-0	1.50 +0.10/-0	1.50 +0.10/-0	1.50 +0.10/-0
D ₁	-	1.00±0.10	1.00±0.10	1.00±0.10	1.00±0.10	1.50±0.10	1.50±0.10
E	1.75±0.10	1.75±0.10	1.75±0.10	1.75±0.10	1.75±0.10	1.75±0.10	1.75±0.10
F	3.50±0.05	3.50±0.05	3.50±0.05	3.50±0.05	3.50±0.05	5.50±0.05	5.50±0.05
Unit :	mm	mm	mm	mm	mm	mm	mm

9. PACKAGE DIMENSION AND QUANTITY

Size	2220	
Chip Thickness	1.40±0.15 1.60±0.20 2.00±0.20	2.50±0.30 2.80±0.30
A ₀	<5.80	<5.80
B ₀	<6.50	<6.50
T	0.30±0.10	0.30±0.10
K ₀	<2.50	<3.10
W	12.00±0.20	12.00±0.20
P ₀	4.00±0.10	4.00±0.10
10xP ₀	40.00±0.20	40.00±0.20
P ₁	8.00±0.10	8.00±0.10
P ₂	2.00±0.05	2.00±0.05
D ₀	1.50 +0.10/-0	1.50 +0.10/-0
D ₁	1.50±0.10	1.50±0.10
E	1.75±0.10	1.75±0.10
F	5.50±0.05	5.50±0.05
Unit :	mm	mm

9.2. REEL DIMENSIONS

Size	0402, 0603, 0805, 1206, 1210		1808, 1812, 2220
Reel size	7"	13"	7"
C	13.0 +0.5/-0.2	13.0 +0.7/-0.3	13.0 +0.5/-0.2
W ₁	8.4 +1.5/-0	8.4 +2.0/-0	12.4 +2.0/-0
W	14.4max	14.4max	shall accommodate tape width without interference
A	178.0 ±0.10	330.0 ±1.0	178.0 ±0.10
N	60.0 +1.0/-0	100 ±1.0	60.0 +1.0/-0

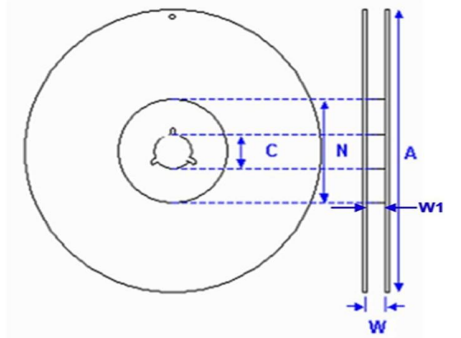

Fig. 9.3 The dimension of reel

10. APPLICATION NOTES

STORAGE

To prevent the damage of solderability of terminations, the following storage conditions are recommended :

Indoors under 5 ~ 40°C and 20% ~ 70% RH.

No harmful gases containing sulfuric acid, ammonia, hydrogen sulfide or chlorine.

Packaging should not be opened until the capacitors are required for use. If opened, the pack should be re-sealed as soon as is practicable. Taped product should be stored out of direct sunlight, which might promote deterioration in tape or adhesion performance. The product is recommended to be used within 12 months after shipment and checked the solderability before use.

HANDLING

Chip capacitors are dense, hard, brittle, and abrasive materials. They are liable to suffer mechanical damage, in the form of cracks or chips. Chip Capacitors should be handled with care to avoid contamination or damage. To use vacuum or plastic tweezers to pick up or plastic tweezers is recommended for manual placement. Tape and reeled packages are suitable for automatic pick and placement machine.

PREHEAT

In order to minimize the risk of thermal shock during soldering, a carefully controlled preheat is required. The rate of preheat should not exceed 3°C per second.

SOLDERING

Use mildly activated rosin fluxes do not use activated flux. The amount of solder in each solder joint should be controlled to prevent the damage of chip capacitors caused by the stress between solder, chips, and substrate.

a.) Hand soldering :

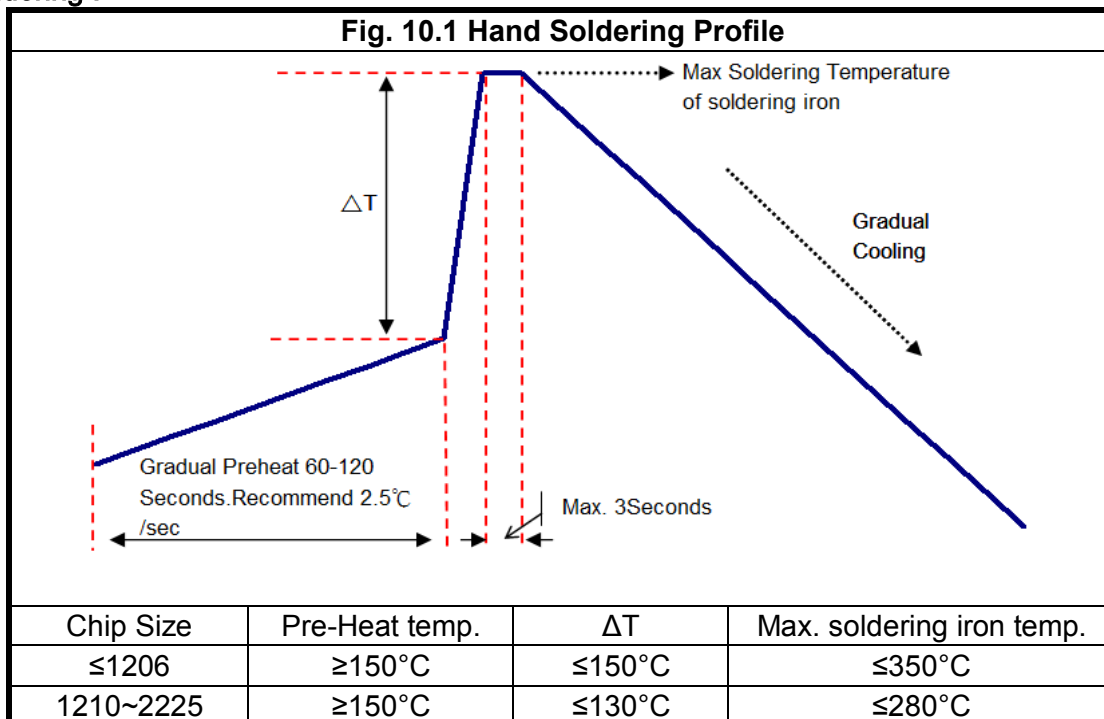

* Soldering iron tip diameter ≤ 1.0 mm and wattage max. 20W.

* The Capacitors shall be pre-heated and that the temperature gradient between the devices and the tip of the soldering iron.

* The required amount of solder shall be melted on the soldering tip.

* The tip of iron should not contact the ceramic body directly.

* The Capacitors shall be cooled gradually at room temperature after soldering.

* Forced air cooling is not allowed.

10. APPLICATION NOTES

b.) Reflow soldering :

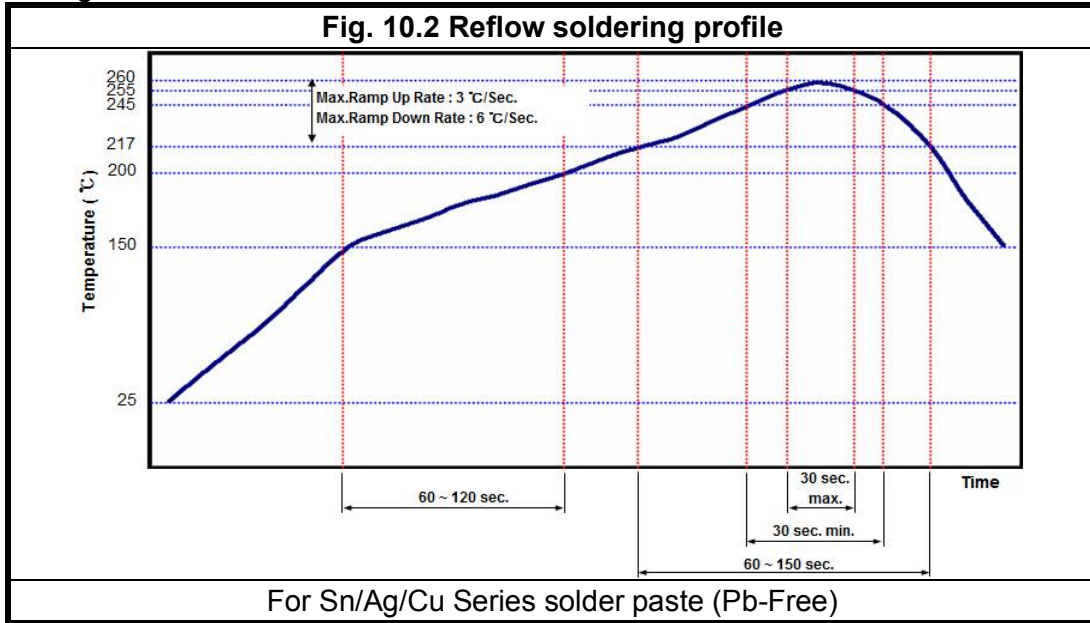

c.) Wave soldering :

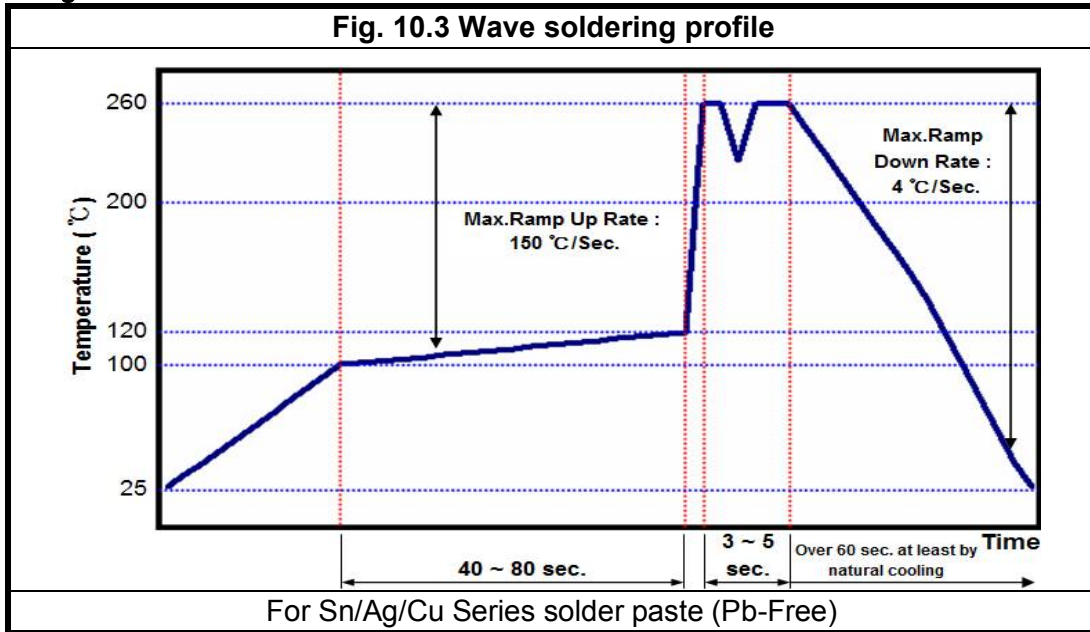

Soldering conditions :

Class I :

Size Inch (mm)	Temper. Cher.	Capacitance	Condition	
			Wave	Reflow
≤0402 (1005)	Class I	All	X	O
0603 (1608)	Class I	All	O	O
0805 (2012)	Class I	All	O	O
		Thickness >0.95mm	X	O
≥1210 (3225)	Class I	All	X	O
Coating Products	All	All	X	O

10. APPLICATION NOTES

Soldering conditions :

Class II :

Size Inch (mm)	Temper. Cher.	Capacitance	Condition	
			Wave	Reflow
≤0402 (1005)	Class II	All	X	O
0603 (1608)	Class II	Cap. <2.2μF	O	O
		Cap. ≥2.2μF	X	O
0805 (2012)	Class II	Thickness ≤ 0.95mm	O	O
		Thickness > 0.95mm	X	O
1206 (3216)	Class II	Thickness ≤ 0.95mm	O	O
		Thickness > 0.95mm	X	O
≥1210 (3225)	Class II	All	X	O
Coating Products	All	All	X	O

Soldering height :

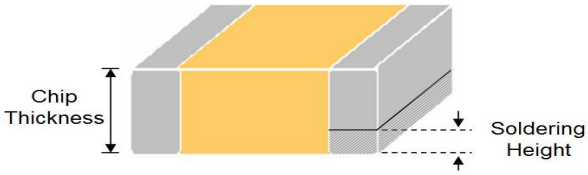
<p>The solder climbing minimum height is suggesting to 25% of chip thickness or 500um whichever is less. (Reference from IPC-610E)</p>	
---	---

COOLING

After soldering, cool the chips and the substrate gradually to room temperature. Natural cooling in air is recommended to minimize stress in the solder joint.

CLEANING

All flux residues must be removed by using suitable electronic-grade vapor-cleaning solvents to eliminate contamination that could cause electrolytic surface corrosion. Good results can be obtained by using ultrasonic cleaning of the solvent. The choice of the proper system is depends upon many factors such as component mix, flux, and solder paste and assembly method. The ability of the cleaning system to remove flux residues and contamination from under the chips is very important.

Notice of HMT Series

The standard AEC-Q200 series capacitors are mainly used on general automotive equipment without safety considerations. Please select SAFETY concern type or contact our company in advanced if you intend to use capacitor for designing the equipment which may damage itself and the safety of third party. If necessary, please consider to add the protect circuit in devising process and obtaining fully safety evaluation. The contents of the acknowledgments only used for our parent company, marketing subsidiaries and official marketing agents who purchase our products. Not applicable for the other nonofficial channels.

Surface coating products are not suitable cleaning/washing by solvent

11. Typical Bending Cracks of MLCC

MLCC ceramic body is consisted of rigidity material. It will be suffered compressive and tensional stress when the carried board is bended. If the suffered stress is over ceramic body strength, the bending crack is occurred. **Therefore, the bending crack will be only occurred after soldering process.**

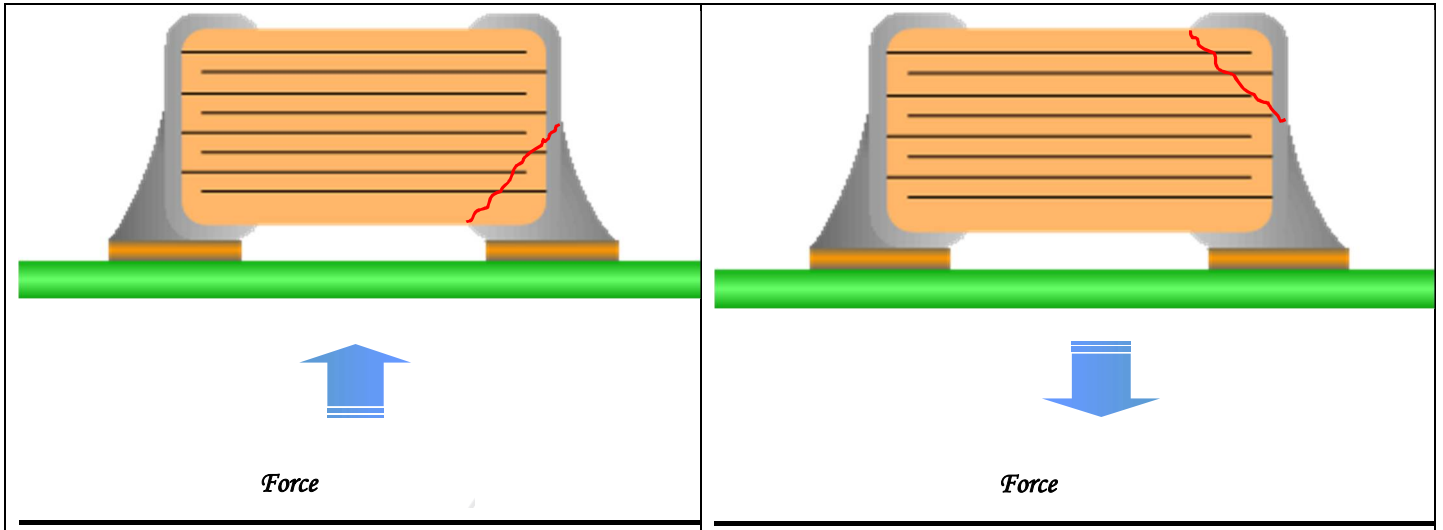

12. The stress v.s. position on PCB during bending

Chip mounting close to board separation point

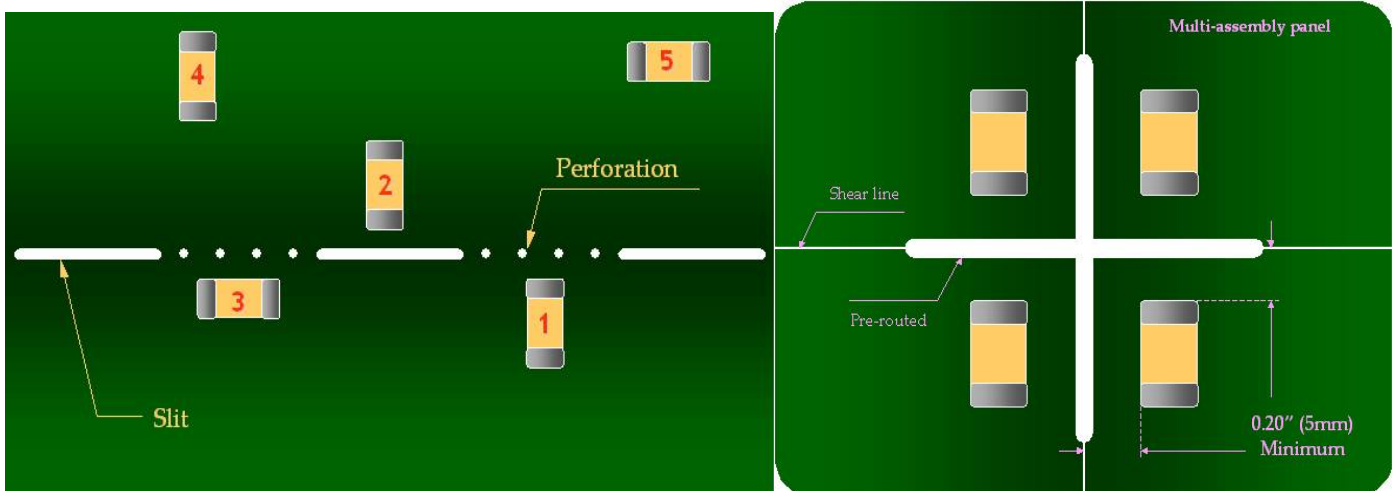

Magnitude of stress $1 > 2 \approx 3 > 4 > 5$

13. Structure

HMT soft termination series is added a special termination material(Ultra-Buffer or Anti-Bend)between ceramic body and Ni-barrier that can absorb mechanical stress to prevent bending crack occurred

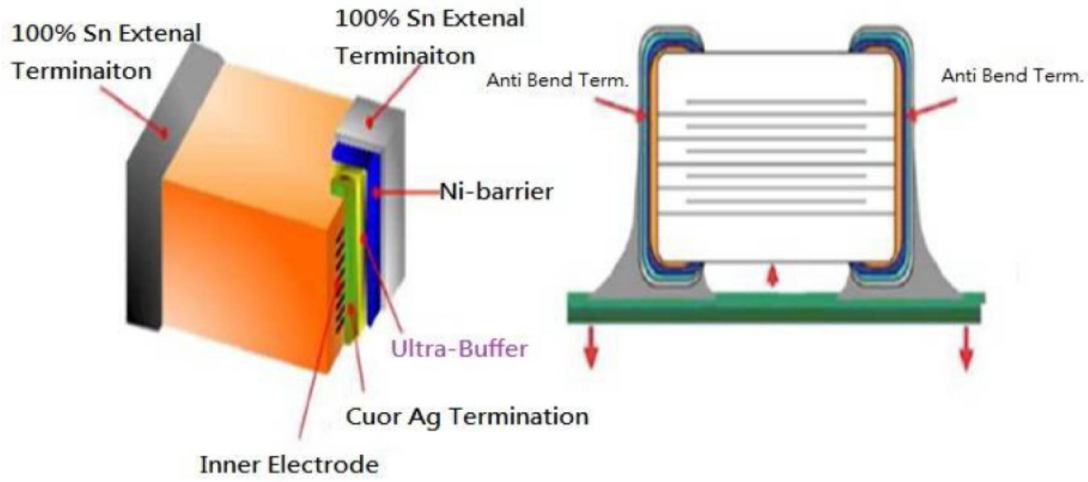

14. Illustration of Bending Test

