



# HITANO ENTERPRISE CORP.

7F-7, No. 3, Wu Chuan 1<sup>st</sup> Road, New Taipei Industrial Park,  
New Taipei City, TAIWAN, R.O.C.  
Tel: +886 2 2299 1331 Fax: +886 2 2298 2466

## Data Sheet

Customer: \_\_\_\_\_

Product: Thick Film Wide Terminal Chip Resistor  
\_\_\_\_\_

Size : 0612/1225  
\_\_\_\_\_

Issued Date: 16-March-2023  
\_\_\_\_\_

Edition: Ver. 1  
\_\_\_\_\_

### Record of change

Date	Ver.	Description	Page

#### VENDOR :

**HITANO ENTERPRISE CORP.**

7F-7,NO.3,WUCHUAN1ST ROAD,  
NEW TAIPEI INDUSTRIAL PARK,  
NEW TAIPEI CITY, TAIWAN, R.O.C.  
TEL:+886222991331(REP.)  
FAX:+886222982466



#### MAKER :

**Prosperity Dielectric Co., Ltd.**

No.220-1, Sec. 2, Nanshan Rd., Lujhu, Taoyuan  
33860, Taiwan, R.O.C



### 1. Features

- High power rating to 2W and compact size.
- High reliability and high precision (1%).
- Compatible with wave and reflow soldering.
- Suitable for lead free soldering.
- Meet AEC-Q200, RoHS compliant & Halogen Free.

### 2. Applications

- Power supply.
- Industry controller.
- Digital meter, Consumer electronics, M/B.
- LED Lighting.
- Automotive devices.

### 3. Dimension and Construction

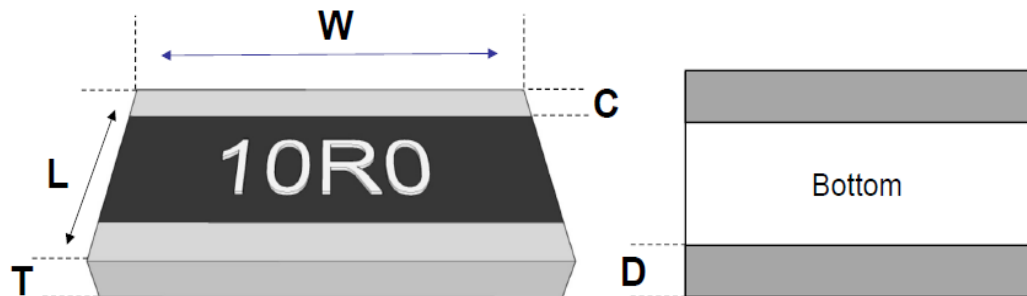

Unit: mm

Type	L	W	C	D	T
HWCF06	1.60±0.20	3.20±0.20	0.25±0.20	0.40±0.20	0.60±0.15
HWCF25	3.10±0.20	6.30±0.20	0.45±0.20	0.75±0.20	0.60±0.15

#### 4. Power Derating Curve

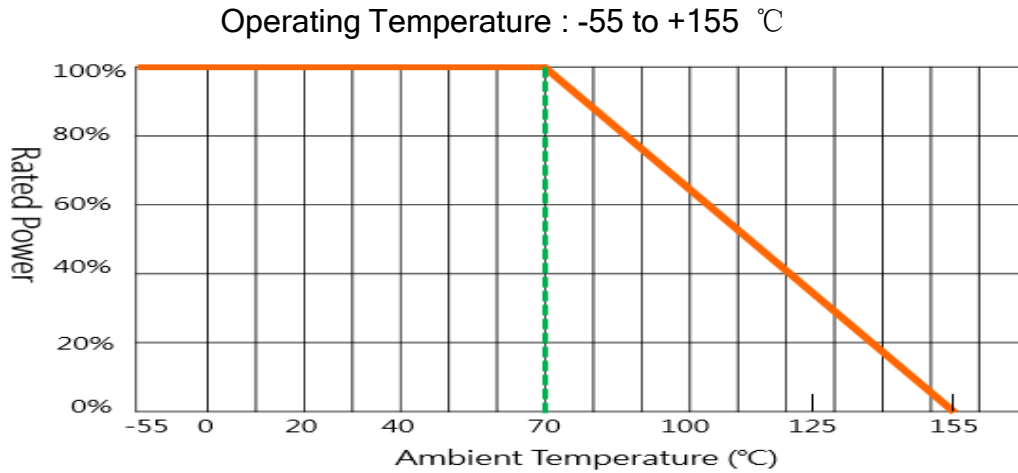

#### 5. Rating

Type	Size	Rating at 70°C (W)	Max. Work (V)	Max. Overload (V)	Resistance Tolerance	Temperature Coefficient (ppm/°C)	Resistance		Standard Resistance Values
							Min. (Ω)	Max. (Ω)	
HWCF06	0612	1W	200V	400V	±1%(F)	±200	1	4.64	E24/E96
					±1%(F)	±100	4.7	1M	E24/E96
					±5%(J)	±200	1	4.3	E24
					±5%(J)	±100	4.7	1M	E24
HWCF25	1225	2W	200V	400V	±1%(F)	±200	1	4.64	E24/E96
					±1%(F)	±100	4.7	1M	E24/E96
					±5%(J)	±200	1	4.3	E24
					±5%(J)	±100	4.7	1M	E24

Note:

- (i)  $E = \sqrt{P * R}$  or Max. Working Voltage whichever is lower.
- (ii) E: Working Voltage(V), P: Rated Power (W), R: Resistance Value(Ω)
- (iii) Solder-pad and trace size influences should be evaluated, and board surface temperature should keep not exceed 105°C when working.

## 6.Part Number

Type	Si ze	Tolerance.	Packing	Watt	R Codes	TCR	Special Code
<b>HWCF</b>	<b>06</b> :0612	<b>E</b> :±1%	Paper: 0612	<b>H</b> : 1W	<del>XXXX</del>	<b>L</b> : 200	<b>M</b> : Meet AEC-Q200
	<b>25</b> :1225	<b>J</b> :±5%	<b>I</b> : 5Kpcs  Plastic: 1225 <b>P</b> : 4Kpcs	<b>J</b> : 2W	<del>XXX</del>  ±5% 3 digits  ±1%: 4 digits	<b>N</b> : 100	

Example:

### **HWCF06FTH1001NM**

→0612 size, tolerance 1%, paper tape, 1W, 1K $\Omega$ , 100ppm, Standard.

### **HWCF25JPJ101 NM**

→1225 size, tolerance 5%, plastic tape, 2W, 100 $\Omega$ , 100ppm, AEC-Q200.

## 7.Marking/Soldering

**Resistance value identify :**

4 Digits marking to identify the resistance value

Example : **1000** →  $100 \times 10^0 = 100 \Omega$

Example : **4R70** →  $4.7 \times 10^0 = 4.7 \Omega$

**Soldering Reference : Applicable for most industrial soldering request.**

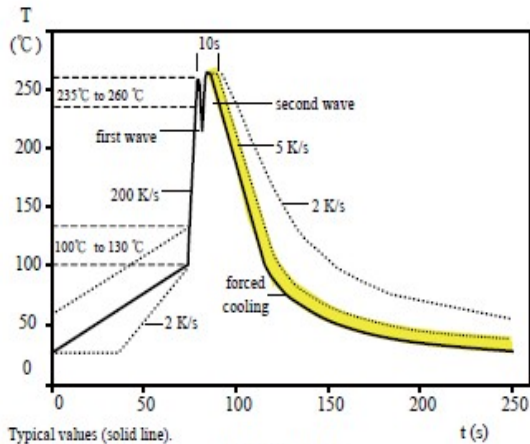

Typical values (solid line).  
 Process limits (dotted line).  
**WAVE soldering.**

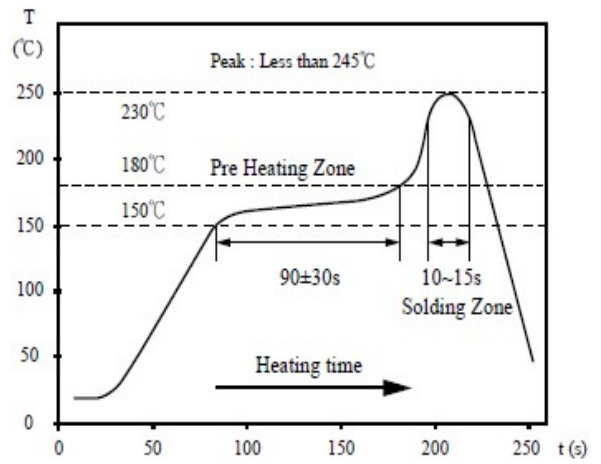

**IR Reflow soldering.**

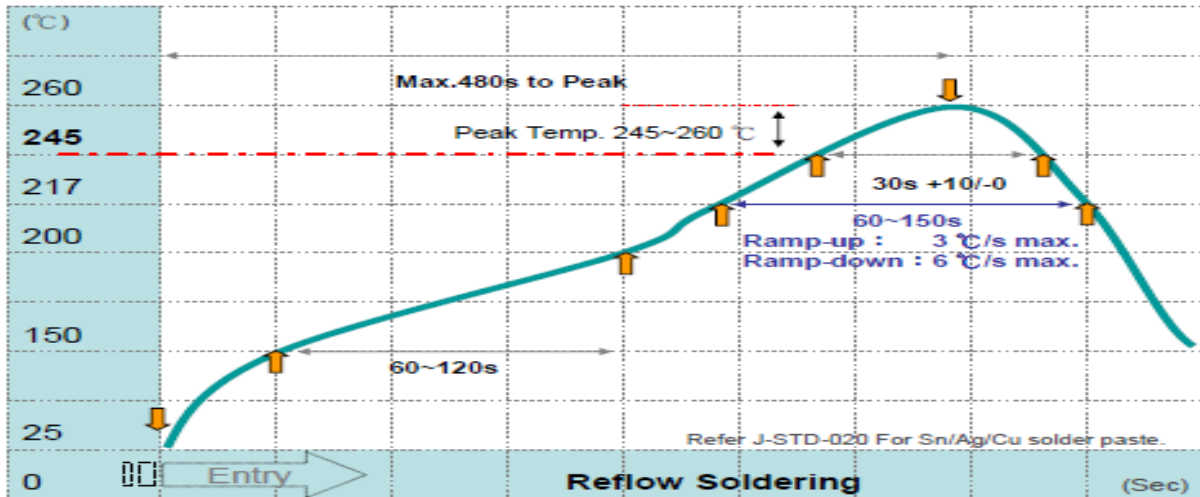

## 8. Reliability Performance

### 8.1 AEC-Q200 Grade

Test	Specification	Refer Methods (AEC-Q200. IEC 60115)
DC Resistance	J: $\pm 5\%$ F: $\pm 1\%$	<b>AEC-Q200 TABLE 7.1</b> <b>IEC 60115-1 / JIS C 5201-1, Clause 4.5</b> Measure the resistance Value.
High Temperature Exposure (Storage)	J: $\Delta R \cong \pm(3\%+0.1\Omega)$ F: $\Delta R \cong \pm(1\%+0.1\Omega)$	<b>AEC-Q200 TABLE 7.3</b> 1000 hrs. @ T=155°C. Unpowered. Measure at 24 $\pm$ 2 hours after test end.
Temperature Cycling	J: $\Delta R \cong \pm(1\%+0.05\Omega)$ F: $\Delta R \cong \pm(0.5\%+0.05\Omega)$ No mechanical damage.	<b>AEC-Q200 TABLE 7.4</b> 1000 Cycles (-55°C to +125°C). Measure at 24 $\pm$ 2 hours after test end.
Moisture Resistance	J: $\Delta R \cong \pm(1\%+0.05\Omega)$ F: $\Delta R \cong \pm(0.5\%+0.05\Omega)$	<b>AEC-Q200 TABLE 7.6</b> Test 65°C/80~100%RH/10Cycles. Measure at 24 $\pm$ 2 hours after test end. (24hrs/cycle).
Biased Humidity	J: $\Delta R \cong \pm(3\%+0.1\Omega)$ F: $\Delta R \cong \pm(1\%+0.1\Omega)$	<b>AEC-Q200 TABLE 7.7</b> 1000 hours 85°C/85%RH, 10% of operating power. Measure at 24 $\pm$ 2 hours after test end.
Operational Life	J: $\Delta R \cong \pm(3\%+0.1\Omega)$ F: $\Delta R \cong \pm(1\%+0.1\Omega)$	<b>AEC-Q200 TABLE 7.8</b> Test 1000hr @ TA=125°C at specified rated power. Measurement at 24 $\pm$ 2 hours after test end.
External Visual	No visual damage and refer PDC marking code.	<b>AEC-Q200 TABLE 7.9</b> Inspect appearance, marking and workmanship.
Physical Dimension	Within the spec.	<b>AEC-Q200 TABLE 7.10</b> Verify physical dimensions to the applicable device detail specification.
Mechanical Shock	Within product specification tolerance and no visible damage.	<b>AEC-Q200 TABLE 7.13</b> Test Peak value: 100g's, Wave: Half-sine, Duration: 6ms, Velocity: 12.3ft/sec.
Vibration	No mechanical damage.	<b>AEC-Q200 TABLE 7.14</b> 5 g's for 20 min., 12 cycles each of 3 orientations. Test from 10-2000 Hz.
Resistance to Solder Heat	J: $\Delta R \cong \pm(1\%+0.05\Omega)$ F: $\Delta R \cong \pm(0.5\%+0.05\Omega)$ No mechanical damage.	<b>AEC-Q200 TABLE 7.15</b> Solder dipping @ 260°C $\pm$ 5°C for 10sec. $\pm$ 1sec.

Thermal Shock	J: $\Delta R \cong \pm(1\%+0.05\Omega)$ F: $\Delta R \cong \pm(0.5\%+0.05\Omega)$ No mechanical damage.	<b>AEC-Q200 TABLE 7.16</b> -55 to 155°C, dwell time 15min. Max transfer time 20sec, 300cycles.
ESD	$\Delta R \cong \pm 5\%$ No mechanical damage.	<b>AEC-Q200-002</b> 330 $\Omega$ /150pF, Test contact min. 2KV.
Solder Ability	Over 95% of termination must be covered with solder.	<b>AEC-Q200 TABLE 7.18</b> a) Baking 155°C 4H, dipping 235°C 5s b) Steam 1H, dipping 215°C 5s c) Steam 1H, dipping 260°C 7s
Flammability	Refer UL-94.	<b>AEC-Q200 TABLE 7.20</b> UL-94 V-0 or V-1 are acceptable.
Board Flex	J: $\Delta R \cong \pm(1\%+0.05\Omega)$ F: $\Delta R \cong \pm(0.5\%+0.05\Omega)$ No mechanical damage.	<b>AEC-Q200 TABLE 7.21</b> Bending 2mm.
Terminal Strength	No mechanical damage	<b>AEC-Q200 TABLE 7.22</b> Force 1.8 Kg for 60 seconds.
Short Time Overload	J: $\Delta R \cong \pm(2\%+0.5m\Omega)$ F: $\Delta R \cong \pm(1\%+0.5m\Omega)$	<b>IEC 60115-1, Clause 4.13</b> 5 × Rated power for 5 seconds
Temperature Coefficient of Resistance	TCR within the spec. (ppm/°C)	<b>IEC 60115-1, Clause 4.8</b> Test temperature: (T1)25°C~(T2)+155°C $TCR(ppm/^\circ C) = (R_2-R_1)/R_1 \times 1 / (T_2-T_1) \times 10^6$

## 9. PACKAGING

### 9.1 Peel Strength of Top Cover Tape

The peel speed shall be about 300 mm/min

The peel force of top cover tape shall between 0.1 to 0.7N

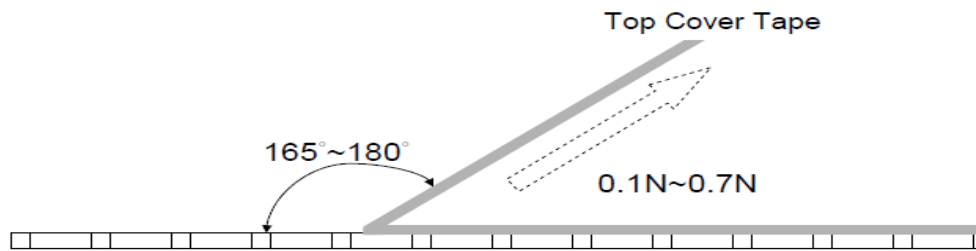

### 9.2 Tape Packaging Dimensions

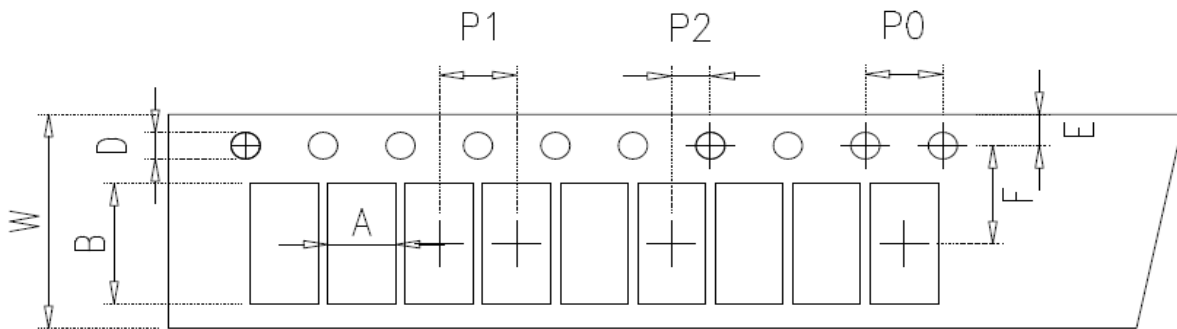

unit:mm

Size	A	B	W	F	E	P1	P2	P0	D
0612	2.00±0.20	3.60±0.20	8.00±0.30	3.50±0.05	1.75±0.10	4.00±0.10	2.00±0.05	4.00±0.10	1.50+0.10/-0
1225	3.50±0.20	6.70±0.20	12.00±0.30	5.50±0.05	1.75±0.10	4.00±0.10	2.00±0.05	4.00±0.10	1.50+0.10/-0



### 9.3 Reel Dimensions

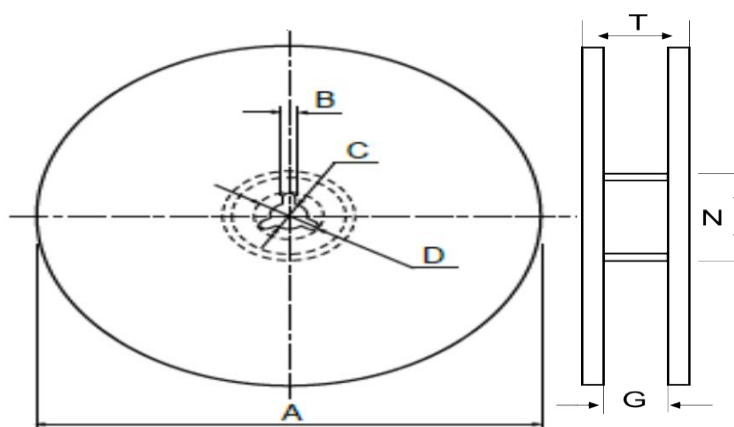

unit:mm

Size	Packaging Q'ty	A	N	C	D	B	G	T
0612	5kpcs/Reel	178.0±2.0	60.0±0.5	13.0±0.5	20(Min.)	2.0±0.5	10.0±1.5	14.9max.
	10kpcs/Reel	254.0±2.0	100.0±1.0	13.5±0.5	20(Min.)	2.0±0.5	10.0±1.5	14.9max.
	20kpcs/Reel	330.0±2.0	100.0±1.0	13.5±0.5	20(Min.)	2.0±0.5	10.0±1.5	14.9max.
1225	4kpcs/Reel	178.0±2.0	60.0±0.5	13.0±0.5	20(Min.)	2.0±0.5	13.8±1.5	16.7max.
	8kpcs/Reel	254.0±2.0	100.0±0.5	13.5±0.5	20(Min.)	2.0±0.5	13.8±1.5	20.0max.
	16kpcs/Reel	330.0±2.0	100.0±1.0	13.5±0.5	20(Min.)	2.0±0.5	13.8±1.5	20.0max.

## 10. Storage & Handling

... Products are recommended to be used up within one year as ensured shelf life.

Check solder ability in case shelf life extension is needed.

... To store products with following condition:

Temperature:5 to 40°C; Humidity: 20 to 70% relative humidity.

### Precaution for use :

The AEC-Q200 series resistors is mainly used on general automotive equipment without safety considerations.

Please contact our company in advanced if you intend to use resistor for designing the equipment which may damage itself and the safety of third party. If necessary, please consider to add the protect circuit in devising process and obtaining fully safety evaluation. The contents of the acknowledgment is only used for our parent company, marketing subsidiaries and official marketing agents who purchase our products. Not applicable for the other nonofficial channels.

**\*\* If you have any request not find from above datas, please contact our sales for further information, we may do our best to meet your request.**