

Data Sheet

Customer: _____

Product: Ceramic Disc Capacitor - Class II _____

Type : H _____

Issued Date: 31-Jan.-2023 _____

Edition: Ver. 2 _____

Record of change

Date	Ver.	Description	Page
30-Dec.-2016	1		
31-Jan.-2023	2	Revised Part No.	

HITANO ENTERPRISE CORP.

7F-7, No. 3, Wu Chuan 1st Road, New Taipei Industrial Park,

New Taipei City, TAIWAN, R.O.C.

Tel: +886 2 2299 1331 (Rep.)

Fax: +886 2 2298 2466, 2298 2969

Prepared by	Checked by	Approved by	Accepted by (customer)
31-Jan.-2023	31-Jan.-2023	31-Jan.-2023	
Hwa Wu	Andy Hsu	Arthur Su	

FEATURES

- Large capacitance in small size
- Non linear temperature coefficient of capacitance

Part No. Designation

Example	H	P	050	471	K	-	L	2	5	5	B
	(1)	(2)	(3)	(4)	(5)		(6)	(7)	(8)	(9)	(10)

1. Class II — Type 'H'

2. Temperature Coefficient (Ref. Fig

Code	Temp. Range	Cap. Change	EIA Code	Cap. Change
P	-25°C ~ +85°C	±10%	Y5P	±10%
Z	+10°C ~ +85°C	+22% -55%	Z5U	+20% -56%
V		+30% -80%	Z5V	+22% -82%

3. Rated Voltage (D.C.)

Code	Voltage	Code	Voltage
050	50V	500	500V
063	63V	630	630V
100	100V	1K0	1000V

4. Rated Capacitance

Code	Cap. (PF)	Code	Cap. (PF)
101	100PF	821	820 PF
121	120PF	102	1,000 PF
151	150PF	152	1,500 PF
181	180PF	222	2,200 PF
221	220PF	332	3,300 PF
271	270PF	392	3,900 PF
331	330PF	472	4,700 PF
391	390PF	682	6,800 PF
471	470PF	822	8,200 PF
561	560PF	103	10,000 PF
681	680PF		

5. Tolerance On Rated Capacitance

Code	Tolerance	Rated T.C.
K	±10%	P
M	±20%	P, Z
Z	+80-20%	Z, V

6. Lead Shape. (Ref. Fig. 3.)

Code	Type	
K	Bulk	Short Kink
S		Short Straight
L		Long Straight
A	Taping	Inside Kink
B		Straight

7. Lead Spacing. (F)

Code	Dimension. (mm)		
	K	S	L
2	---	2.5±0.8	2.5±0.8
5	5.0±0.8	5.0±0.8	5.0±0.8
6	---	6.3±0.8	6.3±0.8
7	---	7.5±0.8	7.5±0.8
0	9.5±0.8	9.5±0.8	9.5±0.8

8. Lead Length. (L)

Code	Dimension (mm)		
	K	S	L
5	5.0±0.8	5.0±0.8	
6	6.0±0.8	6.0±0.8	
0	10.0±0.8	10.0±0.8	
1	---	---	25min

9. Lead Wire. (d)

Code	Dia(φ mm)	Rated Voltage (D.C.)
5	0.5±0.05	50V~500V
6	0.6±0.05	1KV

* Taping type lead dia. 0.6mm only.

10. Package

Code	Package	Q'ty
B	Bulk	1000pcs
A	Ammo Pack	2000pcs
R	Tape & Reel	2500pcs

Fig. 2 (T.C. %)

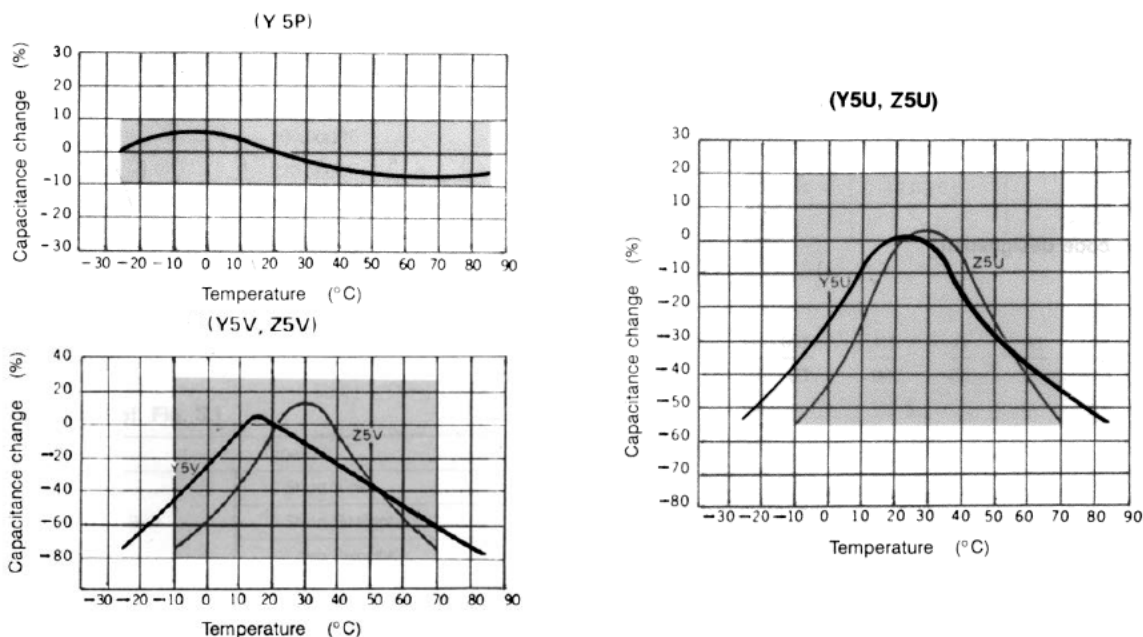

Dimension & Capacitance Range

Dimension (mm)				Capacitance Range (pF)								
Dia. (D) max	Lead Spacing (F)			50 ~ 100V			500 ~ 630V			1KV		
	K	S	L	P	Z	V	P	Z	V	P	Z	V
5.5	5.0±0.8 to 10.0±0.8	2.5±0.8 to 10.0±0.8	2.5±0.8 to 10.0±0.8	151 - 222	102 - 502	102-103	151 - 681	102 - 222	102 - 222	101 - 681	102 - 122	102 - 122
6.5				272 - 332	562 - 822	153-223	821 - 102	272 - 392	332 - 472	821 - 102	152 - 222	152 - 222
7.5				342 - 472	103 - 123	---	152 - 202	402 - 472	562 - 682	122	272	272 - 472
8.5				562 - 682	153	---	222 - 302	502 - 682	822-103	152 - 182	332 - 502	562 - 103
9.5				---	183 - 203	---	332	---	---	202 - 222	562	---
10.5				---	223	---	392 - 472	103	---	272 - 332	103	---
12.5				---	---	---	502 - 682	---	223	392 - 472	123 - 153	153
14.5				---	---	---	103	223	333	---	183	223
16.5	---	---	---	---	---	473	103	223	333			

SPECIFICATION & TEST

No.	Item	Performance	Test Method
1.	Visual & Mechanical	To meet the specification	The product shall be inspected for visible evidence of defect
2.	Marking	To be clear and legible	Marking shall be tested with ace ton
3.	Voltage Proof (Between terminal)	No failure	2.5 times the rated voltage shall be applied for 1 to 5 sec. Charging and discharging current shall be limited to 50mA max
4.	Insulation resistance	10,000MΩ min	Shall be measured 1 minute after with rated voltage
5.	Capacitance	To be within the specified tolerance	Test frequency : 1KHz ±100Hz Test voltage shall not exceed 5Vrms at 25±2°C
6.	Dissipation Factor (Tan δ) (%)	Characteristic P, Z : 2.5% max V : 5% max	Same condition as above (Item 5)

Lead Shape (Fig. 3)

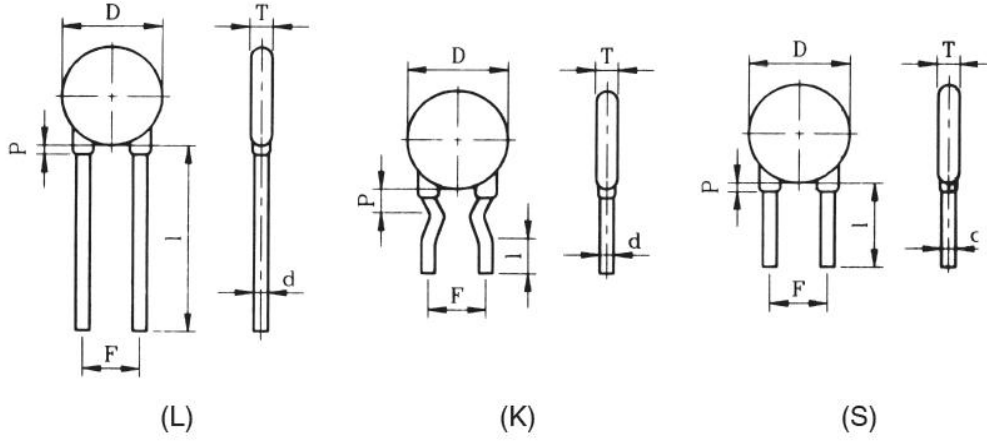

Taping Specification

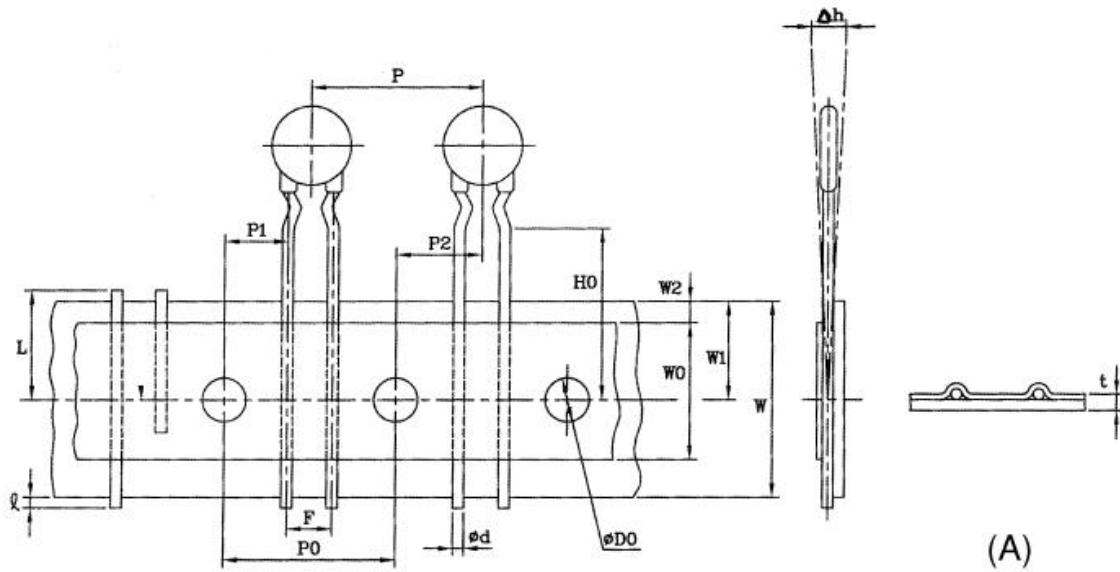

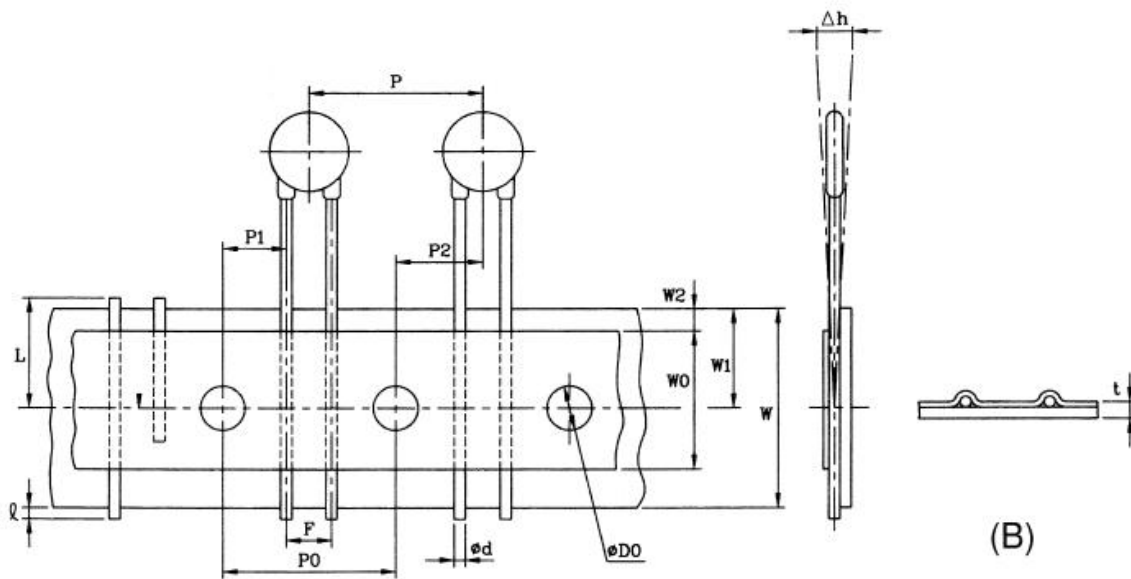

Symbol	P	P ₀	P ₁	P ₂	φ d	F	Δh	W	W ₀	W ₁	W ₂	D ₀	t	L	H	H ₀
Dimension	12.7	12.7	3.85	6.35	0.6	2.54 5.08 6.35 7.62	0	18	12.5	9	3	4	0.7	11	20.0 23.0	16.0 18.0
Tolerance	±1.0	±0.3	±0.7	±1.0	±0.05	+0.8 -0.2	±2	±0.5	Min	+0.75 -0.5	Max	±0.3	±0.2	Max	+1.5 -1.0	±0.5