

Data Sheet

Customer: _____

Product: Wire Wound Power Inductor – CSS Series _____

Size : 6025/6028/6045/7032/7045/7055/10145/10165
_____ 12555/12565/12575 _____

Issued Date: 30-Oct-2015 _____

Edition: Ver. 2 _____

Record of change

Date	Ver.	Description	Page
3-Aug.-2015	1		
30-Oct.2015	2	Revised packaging details	14

HITANO ENTERPRISE CORP.

7F-7, No. 3, Wu Chuan 1st Road, New Taipei Industrial Park,
New Taipei City, TAIWAN, R.O.C.
Tel: +886 2 2299 1331 (Rep.)
Fax: +886 2 2298 2466, 2298 2969

Prepared by	Checked by	Approved by	Accepted by (customer)
3-Aug.-2015	3-Aug.-2015	3-Aug.-2015	
<i>Andy Hsu</i>	<i>Hwa Wu</i>	<i>Hwa Wu</i>	

WIRE WOUND POWER INDUCTOR CSS SERIES

■ Features

- * The CSS series are characterized by low profile, low DC resistance, and high current handling capacities.
- * Because they are magnetically shielded, these parts can be used in high-density mounting configurations.
- * Flat bottom surface ensures secure, reliable mounting.
- * Provided in embossed carrier tape packaging for use with automatic mounting machines.

■ Application

- * Portable Telephone.
- * Personal Computers.
- * DC/DC Converters, etc.
- * Other Various Electronic Appliance.



■ Part Numbering

CSS	0603	T	4R7	J	□□
SERIES	SIZE	PACKAGE	INDUCTANCE	TOLERANCE	INTERNAL CODE
Wire Wound	6025	T= Tape&Reel	4R7= 3.3uH	M= ±20%	
Shielded	6028		101= 100uH	N= ±30%	
	6045		152= 1500uH		
	7032				
	7045				
	7055				
	10145				
	10165				
	12555				
	12565				
	12575				

POWER INDUCTORS CSS SERIES

CSS6025

1. MECHANICAL DIMENSION

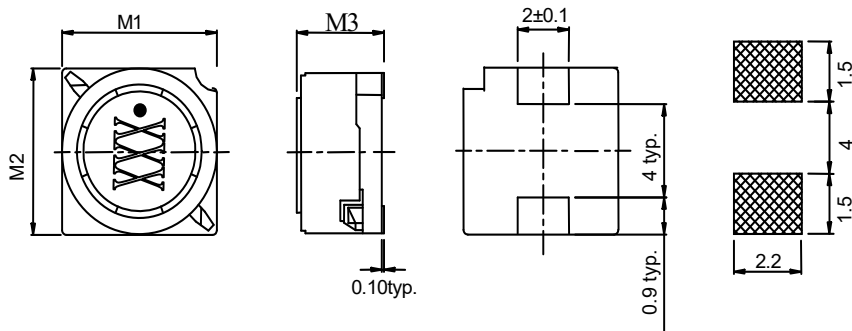

Recommended Patters

UNIT: mm

	DIM.	TOL.
M1	6.0	±0.2
M2	6.0	±0.2
M3	2.5	±0.2

2. ELECTRICAL

PART NO.	L(uH)	DCR(Ω)	RDC Idc1	RDC Idc2
CSS6025T-4R7M	4.7	0.0306	1.5	1.8
CSS6025T-6R8M	6.8	0.0442	1.3	1.5
CSS6025T-100M	10	0.0573	1.0	1.3
CSS6025T-150M	15	0.085	0.88	1.1
CSS6025T-220M	22	0.122	0.73	0.94
CSS6025T-330M	33	0.18	0.59	0.79
CSS6025T-470M	47	0.24	0.48	0.67
CSS6025T-680M	68	0.37	0.42	0.54
CSS6025T-101M	100	0.5	0.33	0.47

- Inductance Tolerance : M:±20% tested at 100KHz
- Operating Temp : -40 to +105°C
- Rated current: smaller value of either Idc1 or Idc2.
Idc1: When based on the inductance change rate (30% below the nominal value)
Idc2: When based on the temperature increase (Temperature increase of 25°C by self heating)
- Inductance measurement: HP4194A at 100KHz
- DCR measurement: 502BC milli-ohm meter.
- RDC measurement: 4284A+42841A+42842C
- MSL : LEVEL 1

POWER INDUCTORS CSS SERIES

CSS6028

1. MECHANICAL DIMENSION

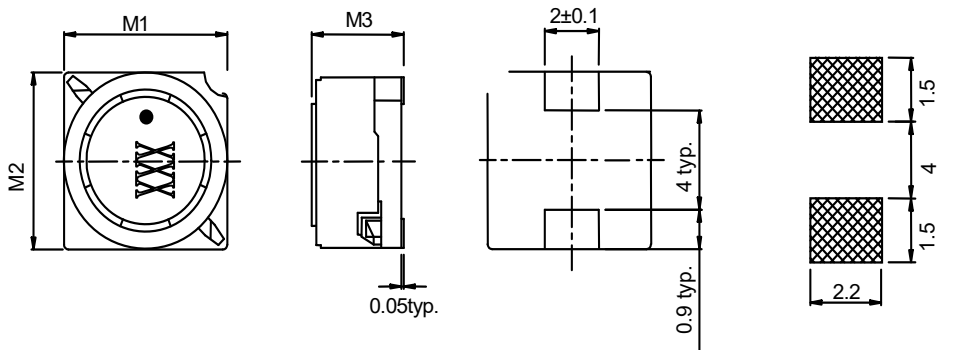

UNIT: mm

	DIM.	TOL.
M1	6.0	±0.2
M2	6.0	±0.2
M3	2.8	±0.2

Recommended Pttrens

2. ELECTRICAL

PART NO.	L(uH)	DCR(Ω)	RDC Idc1	RDC Idc2
CSS6028T-4R7M	4.7	0.0284	1.6	2.5
CSS6028T-6R8M	6.8	0.0354	1.5	2.2
CSS6028T-100M	10	0.0532	1.3	1.8
CSS6028T-150M	15	0.0745	1	1.4
CSS6028T-220M	22	0.104	0.77	1.3
CSS6028T-330M	33	0.148	0.69	1.1
CSS6028T-470M	47	0.21	0.59	0.92
CSS6028T-680M	68	0.29	0.5	0.78
CSS6028T-101M	100	0.43	0.42	0.64
CSS6028T-151M	150	0.65	0.34	0.5
CSS6028T-221M	220	0.98	0.26	0.38

- Inductance Tolerance : M:±20% tested at 100KHz
- Operating Temp : -40 to +105°C
- Rated current: smaller value of either Idc1 or Idc2.
Idc1: When based on the inductance change rate (30% below the nominal value)
Idc2: When based on the temperature increase (Temperature increase of 25°C by self heating)
- Inductance measurement: HP4194A at 100KHz
- DCR measurement: 502BC milli-ohm meter.
- RDC measurement: 4284A+42841A+42842C
- MSL : LEVEL 1

POWER INDUCTORS CSS SERIES

CSS6045

1. MECHANICAL DIMENSION

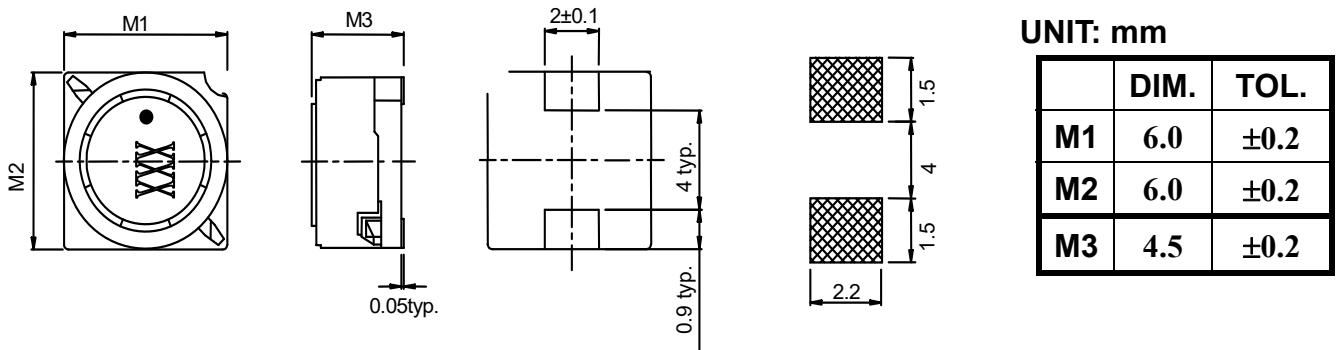

Recommended Pttrens

2. ELECTRICAL

PART NO.	L(uH)	DCR(mΩ) max	RDC Idc1	RDC Idc2
CSS6045T-1R5□	1.5	16	4	4.1
CSS6045T-2R2□	2.2	18	3.3	3.8
CSS6045T-3R3□	3.3	21.5	2.8	3.4
CSS6045T-4R7□	4.7	26.5	2.4	3.2
CSS6045T-6R8□	6.8	33	2	2.8
CSS6045T-100□	10	39	1.6	2.7
CSS6045T-150□	15	59.5	1.3	2.2
CSS6045T-220□	22	82	1.1	1.8

- □ : Inductance Tolerance : M:: ±20%, N: ±30%(tested at 100KHz)
- Operating Temp : -40 to +105°C
- Rated current: smaller value of either Idc1 or Idc2.
 Idc1: When based on the inductance change rate (30% below the nominal value)
 Idc2: When based on the temperature increase (Temperature increase of 25°C by self heating)
- Inductance measurement: HP4194A at 100KHz
- DCR measurement: 502BC milli-ohm meter.
- RDC measurement: 4284A+42841A+42842C
- MSL : LEVEL 1

POWER INDUCTORS CSS SERIES

CSS7032

1. MECHANICAL DIMENSION

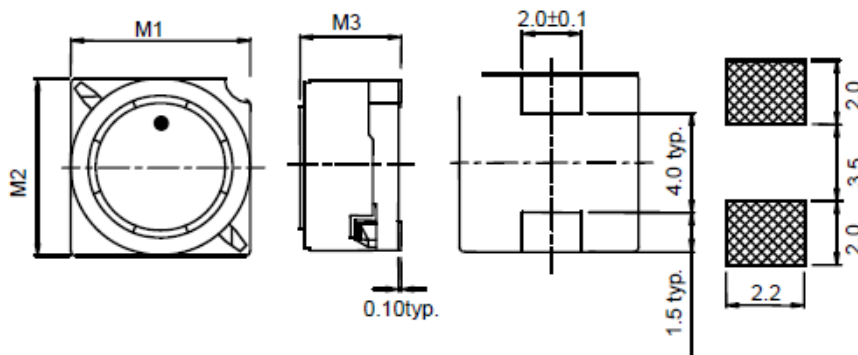

UNIT : mm

	DIM.	TOL.
M1	7	±0.2
M2	7	±0.2
M3	3.2	±0.2

Recommended Patterns

2. ELECTRICAL

Part Number	L(uH)	DCR(Ω) max	RDC(A) max
CSS7032T-3R3M	3.3	0.023	1.9
CSS7032T-4R7M	4.7	0.030	1.7
CSS7032T-6R8M	6.8	0.041	1.6
CSS7032T-100M	10	0.053	1.4
CSS7032T-150M	15	0.075	1.1
CSS7032T-220M	22	0.11	0.96
CSS7032T-330M	33	0.16	0.75
CSS7032T-470M	47	0.24	0.67
CSS7032T-680M	68	0.31	0.59
CSS7032T-101M	100	0.45	0.45
CSS7032T-151M	150	0.65	0.37
CSS7032T-221M	220	1.05	0.29
CSS7032T-331M	330	1.67	0.22
CSS7032T-471M	470	2.05	0.2
CSS7032T-681M	680	3.15	0.16
CSS7032T-102M	1000	4.78	0.13

- Inductance Tolerance : M:±20% tested at 100KHz
- Operating Temp : -40 to +105°C
- Inductance measurement: HP4194A at 100KHz
- DCR measurement: 502BC milli-ohm meter.
- RDC measurement: 4284A+42841A+42842C
- MSL : LEVEL 1

POWER INDUCTORS CSS SERIES

CSS7045

1. MECHANICAL DIMENSION

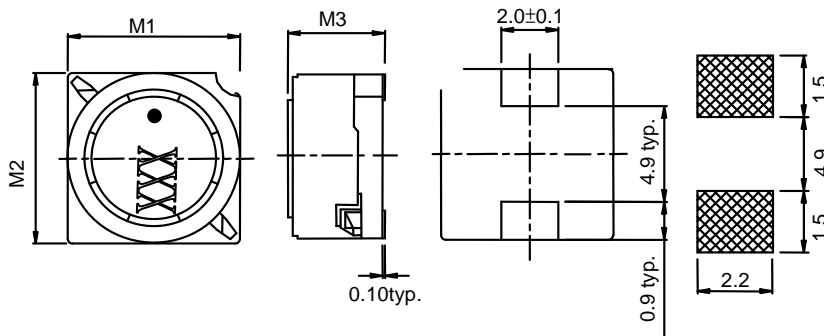

Recommended Patterns

UNIT: mm

	DIM.	TOL.
M1	7.0	±0.2
M2	7.0	±0.2
M3	4.5	±0.3

2. ELECTRICAL

PART NO.	L(uH)	DCR(Ω) max	RDC Idc1	RDC Idc2
CSS7045T-3R3M	3.3	0.02	2.5	2.3
CSS7045T-4R7M	4.7	0.03	2	2.1
CSS7045T-6R8M	6.8	0.039	1.7	1.74
CSS7045T-100M	10	0.036	1.3	1.78
CSS7045T-150M	15	0.052	1.1	1.53
CSS7045T-220M	22	0.061	0.9	1.34
CSS7045T-330M	33	0.096	0.82	1.09
CSS7045T-470M	47	0.125	0.75	0.92
CSS7045T-680M	68	0.175	0.6	0.77
CSS7045T-101M	100	0.25	0.5	0.65
CSS7045T-151M	150	0.34	0.4	0.55
CSS7045T-221M	220	0.52	0.33	0.45
CSS7045T-331M	330	0.74	0.25	0.37
CSS7045T-471M	470	1.05	0.22	0.31
CSS7045T-681M	680	1.48	0.2	0.27
CSS7045T-102M	1000	2.28	0.14	0.25

- Inductance Tolerance : M:±20% tested at 100KHz
- Operating Temp : -40 to +105°C
- Rated current: smaller value of either Idc1 or Idc2.
Idc1: When based on the inductance change rate (10% below the nominal value)
Idc2: When based on the temperature increase (Temperature increase of 20°C by self heating)
- Inductance measurement: HP4194A at 100KHz
- DCR measurement: 502BC milli-ohm meter.
- RDC measurement: 4284A+42841A+42842C
- MSL : LEVEL 1

POWER INDUCTORS CSS SERIES

CSS7055

1. MECHANICAL DIMENSION

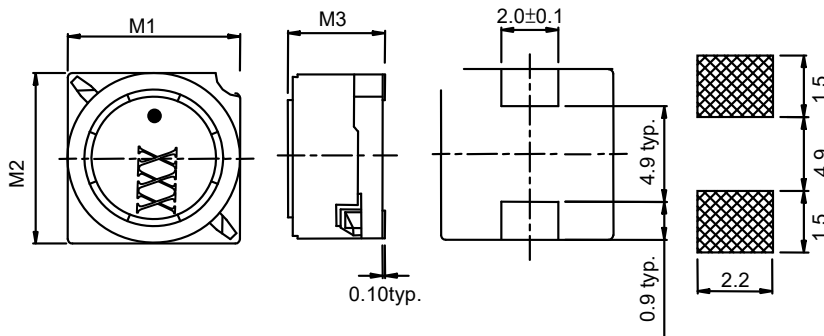

UNIT: mm

	DIM.	TOL.
M1	7.0	±0.2
M2	7.0	±0.2
M3	5.5	±0.3

Recommended Patterns

2. ELECTRICAL

PART NO.	L(uH)	DCR(mΩ) max	RDC Idc1	RDC Idc2
CSS7055T-1R5□	1.5	17.4	6.2	4
CSS7055T-2R2□	2.2	21.7	5.3	3.5
CSS7055T-3R3□	3.3	24	4.3	3.3
CSS7055T-4R7□	4.7	28	3.6	3.1
CSS7055T-6R8□	6.8	34	3	2.8
CSS7055T-100□	10	39.1	2.6	2.5
CSS7055T-150□	15	50.8	2.1	2.2
CSS7055T-220□	22	64.3	1.7	2

- □ : Inductance Tolerance : M:±20% , N: ±30% tested at 100KHz
- Operating Temp : -40 to +105°C
- Rated current: smaller value of either Idc1 or Idc2.
Idc1: When based on the inductance change rate (10% below the nominal value)
Idc2: When based on the temperature increase (Temperature increase of 30°C by self heating)
- Inductance measurement: HP4194A at 100KHz
- DCR measurement: 502BC milli-ohm meter.
- RDC measurement: 4284A+42841A+42842C
- MSL : LEVEL 1

POWER INDUCTORS CSS SERIES

CSS10145

1. MECHANICAL DIMENSION

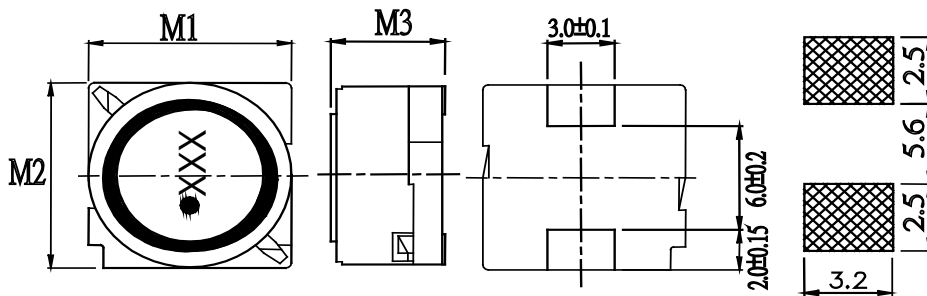

UNIT: mm

	DIM.	TOL.
M1	10.1	±0.3
M2	10.1	±0.3
M3	4.5	±0.3

2. ELECTRICAL

PART NO.	L(uH)	DCR(Ω)	RDC Idc1	RDC Idc2
CSS10145T-3R3□	3.3	0.0161	4.9	3.7
CSS10145T-5R6□	5.6	0.220	3.8	3.2
CSS10145T-100□	10	0.0364	3	2.5
CSS10145T-150□	15	0.0472	2.4	2.2
CSS10145T-220□	22	0.0591	2.1	1.9
CSS10145T-330□	33	0.0815	1.6	1.7
CSS10145T-470□	47	0.1	1.4	1.5
CSS10145T-680□	68	0.14	1.2	1.3
CSS10145T-101□	100	0.2	1	1.1
CSS10145T-151□	150	0.35	0.79	0.81
CSS10145T-221□	220	0.47	0.65	0.7
CSS10145T-331□	330	0.68	0.54	0.58
CSS10145T-471□	470	1.03	0.47	0.47
CSS10145T-681□	680	1.6	0.38	0.38
CSS10145T-102□	1000	2.8	0.32	0.29
CSS10145T-152□	1500	3.4	0.22	0.26

- : Inductance Tolerance : M:±20%, N: ±30% tested at 1KHz
- Operating Temp : -40 to +105°C
- Rated current: smaller value of either Idc1 or Idc2.
Idc1: When based on the inductance change rate (10% below the nominal value)
Idc2: When based on the temperature increase (Temperature increase of 30°C by self heating)
- Inductance measurement: HP4194A at 1KHz
- DCR measurement: 502BC milli-ohm meter.
- RDC measurement: 4284A+42841A+42842C
- MSL : LEVEL 1

POWER INDUCTORS CSS SERIES

CSS10165

1. MECHANICAL DIMENSION

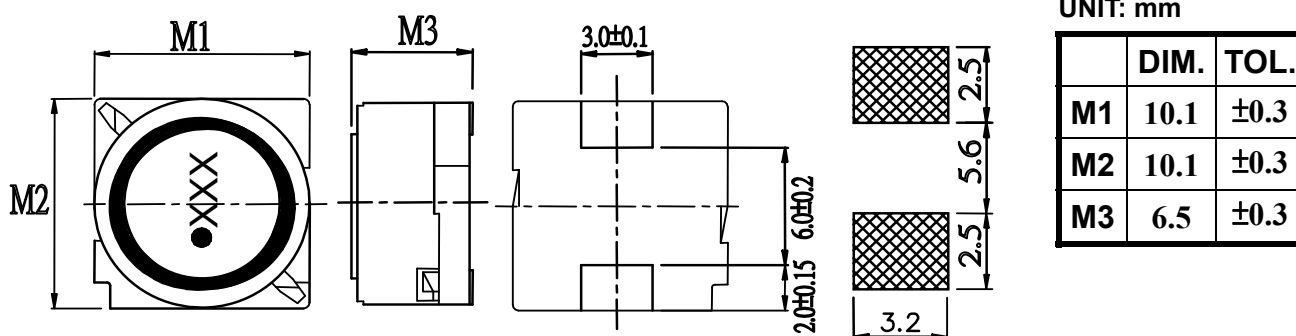

2. ELECTRICAL

PART NO.	L(uH)	DCR(mΩ) max	RDC I _{dc1}	RDC I _{dc2}
CSS10165T-1R5□	1.5	6.7	10.7	6.8
CSS10165T-2R2□	2.2	8.4	8.9	6.3
CSS10165T-3R3□	3.3	9.6	7.8	5.8
CSS10165T-4R7□	4.7	11.7	6.1	4.7
CSS10165T-6R8□	6.8	14	4.6	4.3
CSS10165T-100□	10	18.5	4.1	3.8
CSS10165T-150□	15	27	3.1	3.1
CSS10165T-220□	22	44.8	2.7	2.4

- : Inductance Tolerance : M: ±20%, N: ±30%(tested at 100KHz)
- Operating Temp : -40 to +105°C
- Rated current: smaller value of either I_{dc1} or I_{dc2}.
I_{dc1}: When based on the inductance change rate (10% below the nominal value)
I_{dc2}: When based on the temperature increase (Temperature increase of 30°C by self heating)
- Inductance measurement: HP4194A at 100KHz
- DCR measurement: 502BC milli-ohm meter.
- RDC measurement: 4284A+42841A+42842C
- MSL : LEVEL 1

POWER INDUCTORS CSS SERIES

CSS12555

1. MECHANICAL DIMENSION

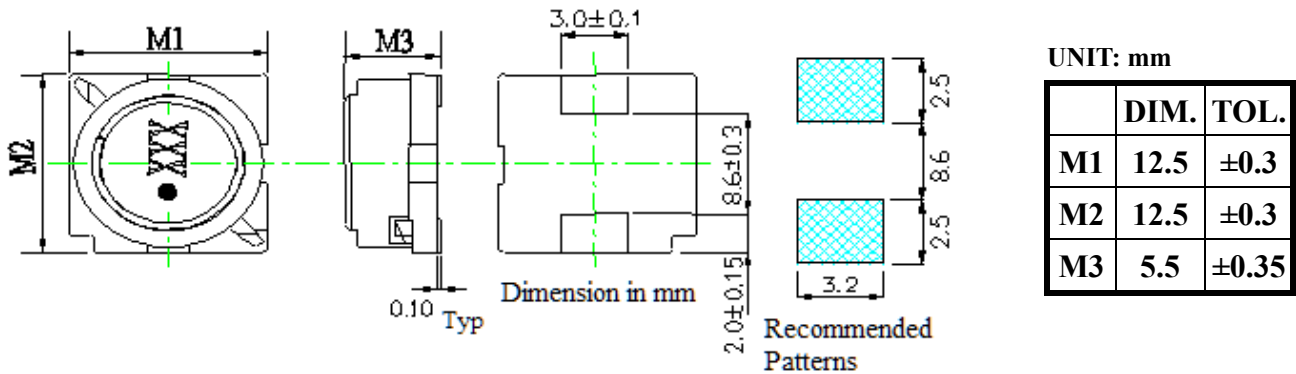

2. ELECTRICAL

PART NO.	L(uH)	DCR(Ω)	RDC Idc1	RDC Idc2
CSS12555T-6R0□	6.0	0.0164	3.6	4.9
CSS12555T-100□	10	0.0215	3.4	4.3
CSS12555T-150□	15	0.0259	2.8	3.9
CSS12555T-220□	22	0.0338	2.3	3.4
CSS12555T-330□	33	0.0415	1.9	3.1
CSS12555T-470□	47	0.0618	1.6	2.5
CSS12555T-680□	68	0.0832	1.3	2.2
CSS12555T-101□	100	0.117	1.1	1.8
CSS12555T-151□	150	0.19	0.88	1.4
CSS12555T-221□	220	0.27	0.72	1.2
CSS12555T-331□	330	0.41	0.59	1
CSS12555T-471□	470	0.52	0.49	0.88
CSS12555T-681□	680	0.76	0.43	0.73
CSS12555T-102□	1000	1.12	0.34	0.6
CSS12555T-152□	1500	1.73	0.29	0.48

- : Inductance Tolerance : M: ±20%, N: ±30%(tested at 100KHz)
- Operating Temp : -40 to +105°C
- Rated current: smaller value of either Idc1 or Idc2.
Idc1: When based on the inductance change rate (10% below the nominal value)
Idc2: When based on the temperature increase (Temperature increase of 30°C by self heating)
- Inductance measurement: HP4194A at 1KHz
- DCR measurement: 502BC milli-ohm meter.
- RDC measurement: 4284A+42841A+42842C
- MSL : LEVEL 1

POWER INDUCTORS CSS SERIES

CSS12565

1. MECHANICAL DIMENSION

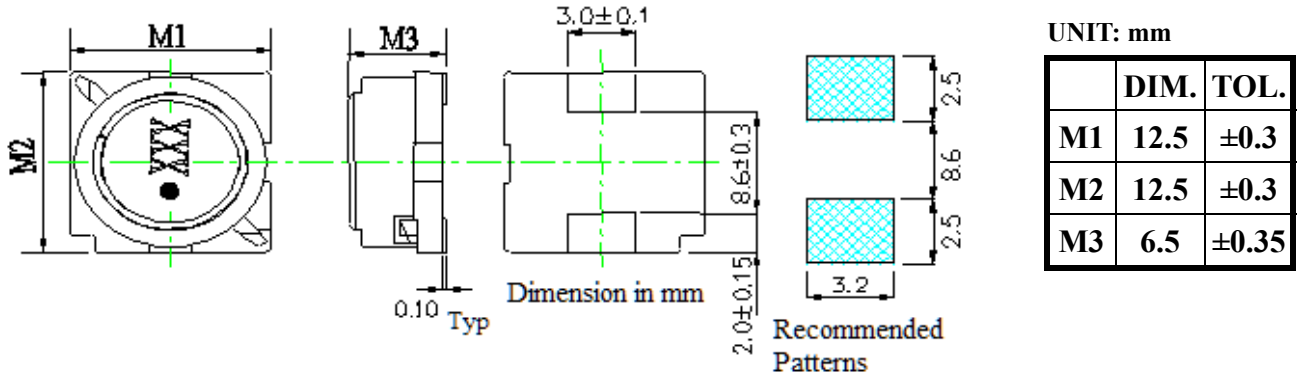

2. ELECTRICAL

PART NO.	L(uH)	DCR(Ω)	RDC Idc1	RDC Idc2
CSS12565T-2R0□	2.0	0.0117	10	6.2
CSS12565T-4R2□	4.2	0.015	7.3	5.5
CSS12565T-7R0□	7.0	0.0177	5.7	5
CSS12565T-100□	10	0.0202	5	4.8
CSS12565T-150□	15	0.0237	4.2	4.4
CSS12565T-220□	22	0.0316	3.5	3.8
CSS12565T-330□	33	0.0406	2.8	3.4
CSS12565T-470□	47	0.0578	2.4	2.8
CSS12565T-680□	68	0.0787	2	2.4
CSS12565T-101□	100	0.123	1.6	1.9
CSS12565T-151□	150	0.273	1	1.2
CSS12565T-221□	220	0.0117	10	6.2

- : Inductance Tolerance : M:: ±20%, N: ±30%(tested at 100KHz)
- Operating Temp : -40 to +105°C
- Rated current: smaller value of either Idc1 or Idc2.
Idc1: When based on the inductance change rate (10% below the nominal value)
Idc2: When based on the temperature increase (Temperature increase of 40°C by self heating)
- Inductance measurement: HP4194A at 1KHz
- DCR measurement: 502BC milli-ohm meter.
- RDC measurement: 4284A+42841A+42842C
- MSL : LEVEL 1

POWER INDUCTORS CSS SERIES

CSS12575

1. MECHANICAL DIMENSION

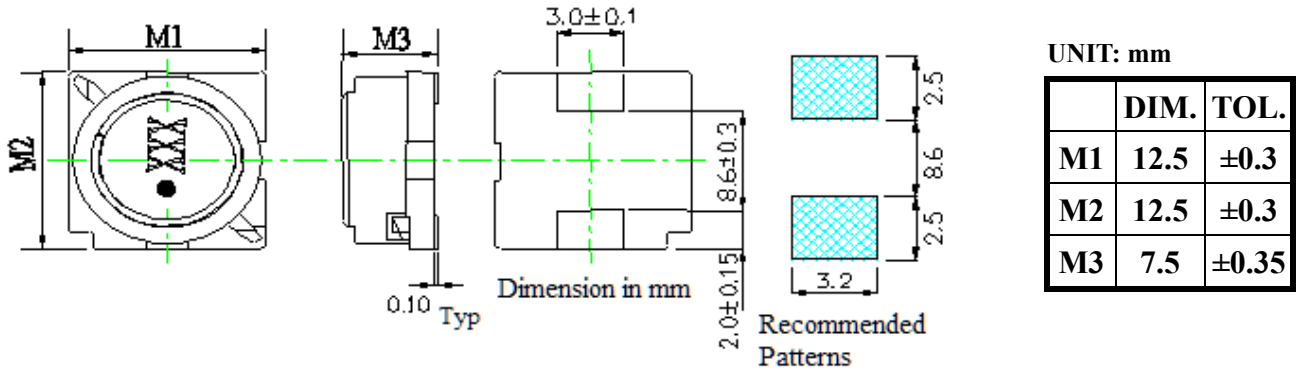

2. ELECTRICAL

PART NO.	L(uH)	DCR(Ω)	RDC Idc1	RDC Idc2
CSS12575T-1R2□	1.2	0.0069	13	8.2
CSS12575T-2R7□	2.7	0.0094	10	7
CSS12575T-3R9□	3.9	0.0104	9	6.7
CSS12575T-5R6□	5.6	0.0116	7.8	6.3
CSS12575T-6R8□	6.8	0.0131	7.2	5.9
CSS12575T-100□	10	0.0156	5.5	5.4
CSS12575T-150□	15	0.0184	4.7	5
CSS12575T-220□	22	0.0263	4	4
CSS12575T-330□	33	0.0395	3.2	3.4
CSS12575T-470□	47	0.0528	2.7	3
CSS12575T-680□	68	0.0778	2	2.4
CSS12575T-101□	100	0.125	1.9	1.9
CSS12575T-151□	150	0.175	1.5	1.6
CSS12575T-221□	220	0.258	1.3	1.3

- □ : Inductance Tolerance : M: ±20%, N: ±30%(tested at 100KHz)
- Operating Temp : -40 to +105°C
- Rated current: smaller value of either Idc1 or Idc2.
Idc1: When based on the inductance change rate (10% below the nominal value)
Idc2: When based on the temperature increase (Temperature increase of 40°C by self heating)
- Inductance measurement: HP4194A at 1KHz
- DCR measurement: 502BC milli-ohm meter.
- RDC measurement: 4284A+42841A+42842C
- MSL : LEVEL 1

WIRE WOUND POWER INDUCTOR CSS SERIES

■ Packaging

■ Reel Dimension

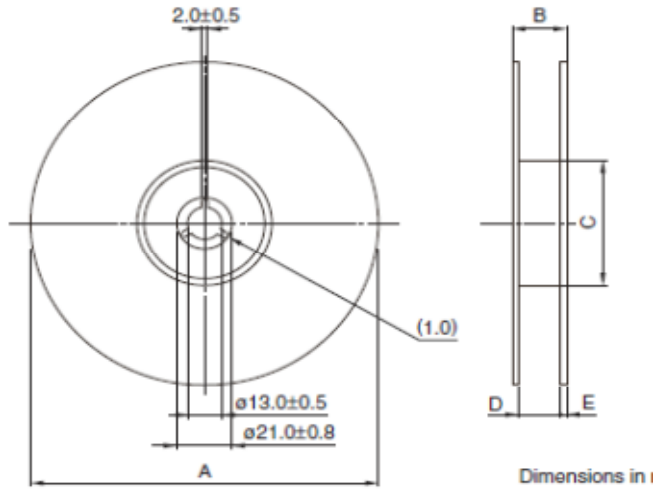

Type	A	B	C	D	E
CSS6025	φ330	22.4	φ50	16.4	2
CSS6028	φ330	22.4	φ50	16.4	2
CSS6045	φ330	22.4	φ50	16.4	2
CSS7032	φ330	22.4	φ50	16.4	2
CSS7045	φ330	22.4	φ50	16.4	2
CSS7055	φ330	22.4	φ50	16.4	2
CSS10145	φ330	30.4	φ50	24.4	2
CSS10165	φ330	30.4	φ50	24.4	2
CSS12555	φ330	30.4	φ50	24.4	2
CSS12565	φ330	30.4	φ50	24.4	2
CSS12575	φ330	30.4	φ50	24.4	2

Unit: mm

■ Tape Dimensions

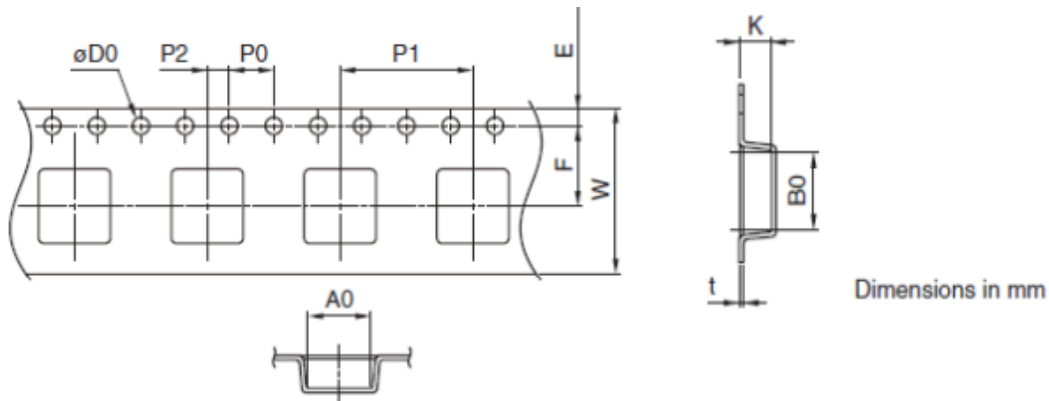

Type	A0	B0	φD0	E	F	P0	P1	P2	W	K	t
CSS6025	6.4	6.4	1.5+0.1/-0	1.75±0.1	7.5±0.1	4.0±0.1	12.0±0.1	2.0±0.05	16.0±0.3	3.1	0.4
CSS6028	6.4	6.4	1.5+0.1/-0	1.75±0.1	7.5±0.1	4.0±0.1	12.0±0.1	2.0±0.05	16.0±0.3	3.1	0.4
CSS6045	6.4	6.4	1.5+0.1/-0	1.75±0.1	7.5±0.1	4.0±0.1	12.0±0.1	2.0±0.05	16.0±0.3	4.9	0.4
CSS7032	7.4	7.6	1.5+0.1/-0	1.75±0.1	7.5±0.1	4.0±0.1	12.0±0.1	2.0±0.05	16.0±0.3	3.6	0.4
CSS7045	7.4	7.6	1.5+0.1/-0	1.75±0.1	7.5±0.1	4.0±0.1	12.0±0.1	2.0±0.05	16.0±0.3	4.8	0.4
CSS7055	7.4	7.6	1.5+0.1/-0	1.75±0.1	7.5±0.1	4.0±0.1	12.0±0.1	2.0±0.05	16.0±0.3	5.5	0.4
CSS10145	10.5	10.5	1.5+0.1/-0	1.75±0.1	11.5±0.1	4.0±0.1	16.0±0.1	2.0±0.05	24.0±0.3	5.0	0.4
CSS10165	10.5	10.5	1.5+0.1/-0	1.75±0.1	11.5±0.1	4.0±0.1	16.0±0.1	2.0±0.05	24.0±0.3	7.1	0.4
CSS12555	13	13	1.5+0.1/-0	1.75±0.1	11.5±0.1	4.0±0.1	16.0±0.1	2.0±0.05	24.0±0.3	6.0	0.4
CSS12565	13	13	1.5+0.1/-0	1.75±0.1	11.5±0.1	4.0±0.1	16.0±0.1	2.0±0.05	24.0±0.3	7.0	0.34
CSS12575	13	13	1.5+0.1/-0	1.75±0.1	11.5±0.1	4.0±0.1	16.0±0.1	2.0±0.05	24.0±0.3	8.0	0.34