

PART NO.		H52N210622		CUSTOMER' S NO.	
特性 CHARACTERISTICS					
NO.	Item	Specification		Condition	
1	Dimensions 尺寸	52mm			
2	Nomial Impedance 标称阻抗	4±15% OHM		At 1.0KHz /2.0V	
3	Input power 输入功率	Rated:5W/ Max: 6W		At4.45V /4.89V	
4	Resonance Frequency 最低共振周波数	120±20%Hz		At 1.0V	
5	S. P. L. 音压位准	79±3 dB(1W/1M)		At200/600/2000/10KHz (Average)	
6	Frepuency Range 有效频宽	F0~20K		Output S.P.L. -10dB	
7	Distortion 失真	5%Max		At 1.0KHz 0.1W/0.1M	
8	Buzze & Rattle 异常音	Not be audible sine wave between at4.89V /115~20KHz. (输入 4.89 V 正弦波从 115 到 20KHz 无异常音)			
9	Polarity 极性	Diaphragm shall move forward. (端子的正极通入电流, 振膜振动方向向前)			
10	Load test 连续负荷测试	Must be normal after load test:Pink noise 24 hours. (粉红噪声连续 24 小时试验后无异常的不良)			
11	High TEMP test 耐热试验	After having been in a test chamber for 48 hours at the condition of +60°C 20~25%R.H and keep 2 hours.(+60°C 20~25%R.H, 48 小时试验常温 2 小时后, 无异常的不良)			
12	Cold TEMP test 耐寒试验	After having been in a test chamber for 48 hours at the condition of -25°C±3°Cand keep 2 hours.(-25°C±3°C, 48 小时试验常温 2 小时后, 无异常的不良)			
13	Humidity test 耐湿试验	After having been in a test chamber for 48 hours at the condition of +40°C 90~95%R.H and keep 4 hours. (+40°C 90~95%R.H,48 小时试验常温 4 小时后, 无异常的不良)			
14	Drop test 跌落试验	The speak shall be dropped 2 times as shown the figure, clause 8 shallbe satisfied. (如右图示 2 次跌落满足异常音试验无异常)			
15	Weld 焊接条件	terminal weld: 350°C/≤2~3sec*2bit. (端子焊接不超过 2~3 秒)			
16	Operating TEMP 工作温度	-25°C To +60°C			

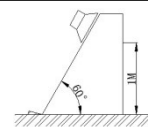

17. MEASUREMENT CIRCUIT 测量线路

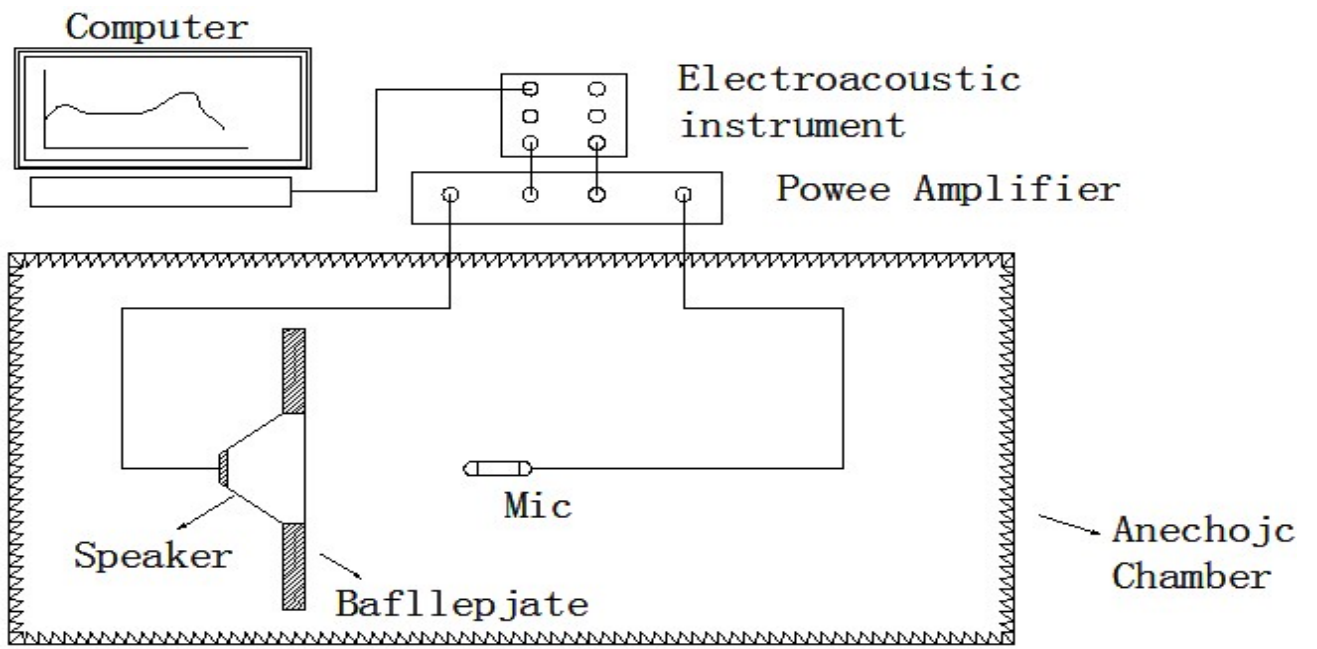

18. TYPICAL FREQUENCY RESPONSE CURVE 频率响应曲线

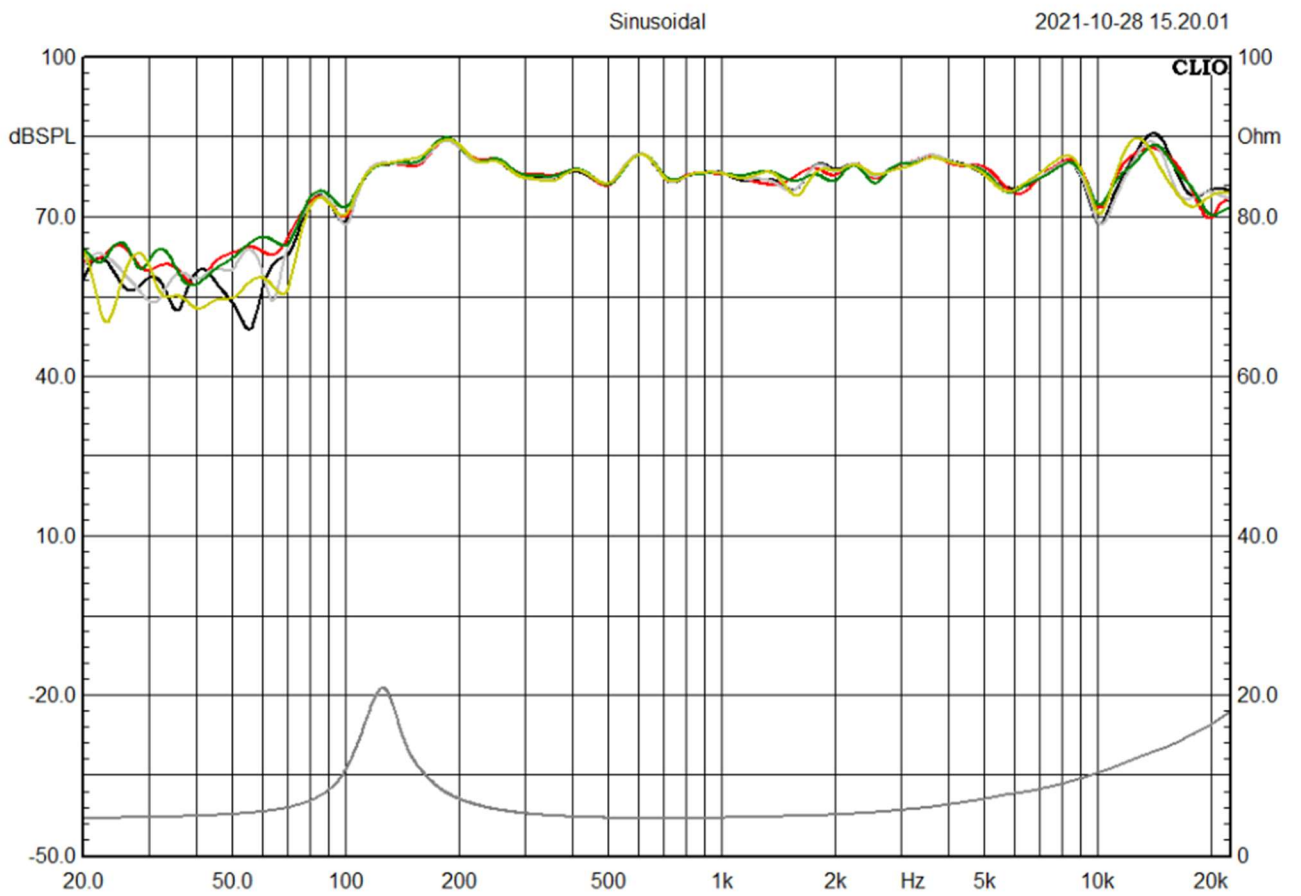

19. APPEARANCE DRAWING 外观尺寸图

--	--	--	--

REVISIONS 版本号	变更内容	E.C.N. NO 设变番号	BY / DATE 签名/日期
A			
B			

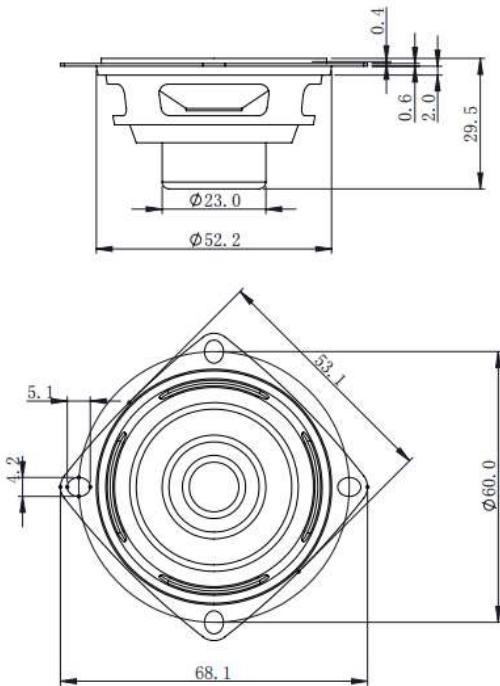

公差 TOLERANCE	材质 Material	处理 Treatment	重量 Weight	单位 Unit	比例	投影法	名称	图号	版本 NR
0~6以下 ±0.1				mm					
6~30以下 ±0.2	承认 APPR BY	审核 CHECK BY	验证 VALIDATE BY	绘图 DRAWN BY					
30~100以下 ±0.3				朱冉					
100~300以下 ±0.5									
角度公差±1°									

公差 TOL	如图	单位 UNIT	mm				顾客 CUSIOMER			
重量 N. G		比例 SCALE	1:1				机种名称 PART NO.	H52N210622		
	日期 DATE	说明 REVISE	日期 DATE	2021-10-28	版本号	0	图番 DRAWING NO.			
1.							核准	审核	制图	
2.										
3.										