

PART NO.		H66FW1604-01		CUSTOMER'S NO.	
特性 CHARACTERISTICS					
NO.	Item	Specification		Condition	
1	Dimensions 尺寸	66mm			
2	Nomial Impedance 标称阻抗	4±15% OHM		At 1.0KHz /2.0V	
3	Input power 输入功率	Rated: 20W		At 8.9V	
4	Resonance Frequency 最低共振周波数	100HZ±20%Hz		At 1.0V	
5	S. P. L. 音压位准	84±3 dB(1W/1M)		At100/300/700/1KHz (Average)	
6	Frepency Range 有效频宽	F0~20K		Output S.P.L. -10dB	
7	Distortion 失真	5%Max		At 1.0KHz 1W/1M	
8	Buzze & Rattle 异常音	Not be audible sine wave between at8.9V /80~5KHz. (输入 8.9 V 正弦波从 80 到 5KHz 无异常音)			
9	Polarity 极性	Diaphragm shall move forward. (端子的正极通入电流, 振膜振动方向向前)			
10	Load test 连续负荷测试	Must be normal after load test:Pink noise 24 hours. (粉红噪声连续 24 小时试验后无异常的不良)			
11	High TEMP test 耐热试验	After having been in a test chamber for 48 hours at the condition of +60°C 20~25%R.H and keep 2 hours.(+60°C 20~25%R.H, 48 小时试验常温 2 小时后, 无异常的 不良)			
12	Cold TEMP test 耐寒试验	After having been in a test chamber for 48 hours at the condition of -25°C±3°Cand keep 2 hours.(-25°C±3°C, 48 小时试验常温 2 小时后, 无异常的 不良)			
13	Humidity test 耐湿试验	After having been in a test chamber for 48 hours at the condition of +40°C 90~95%R.H and keep 4 hours. (+40°C 90~95%R.H,48 小时试验常温 4 小时后, 无异常的 不良)			
14	Drop test 跌落试验	The speak shall be dropped 2 times as shown the figure, clause 8 shallbe satisfied. (如右图示 2 次跌落满足异常音试验无异常)			
15	Weld 焊接条件	terminal weld: 350°C/≤2~3sec*2bit. (端子焊接不超过 2~3 秒)			
16	Operating TEMP 工作温度	-25°C To +60°C			

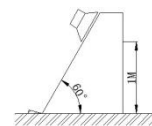

7. MEASUREMENT CIRCUIT 测量线路

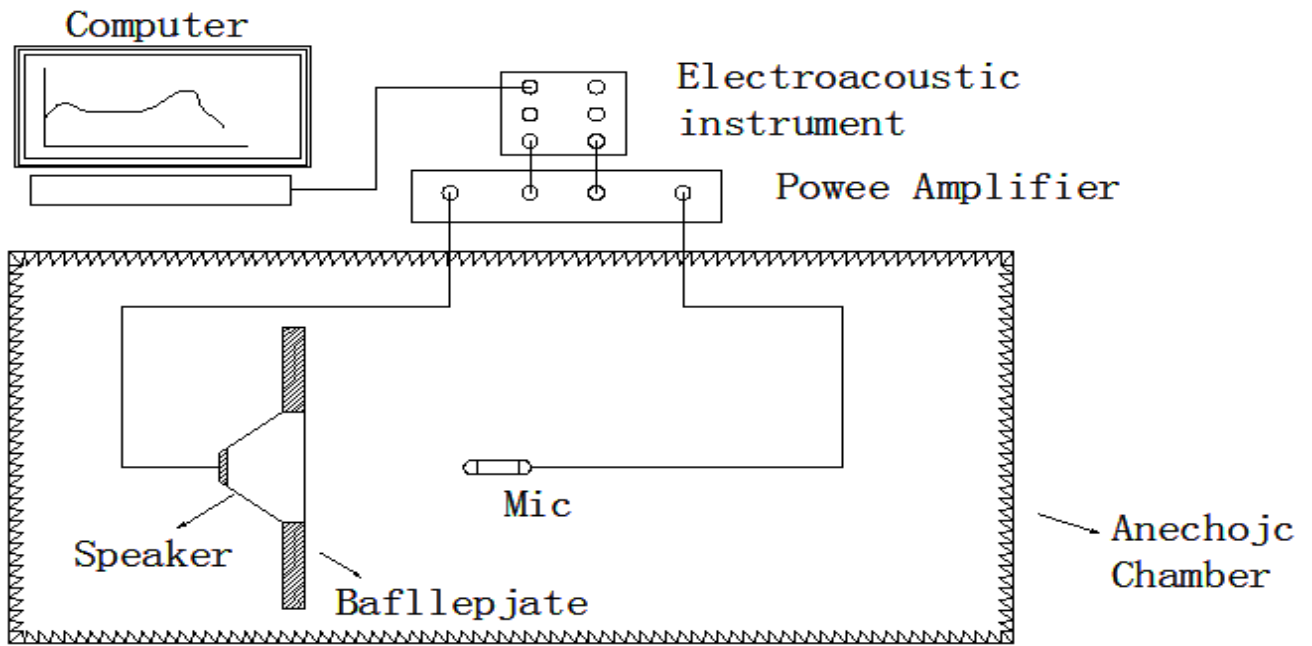

18. TYPICAL FREQUENCY RESPONSE CURVE 频率响应曲线

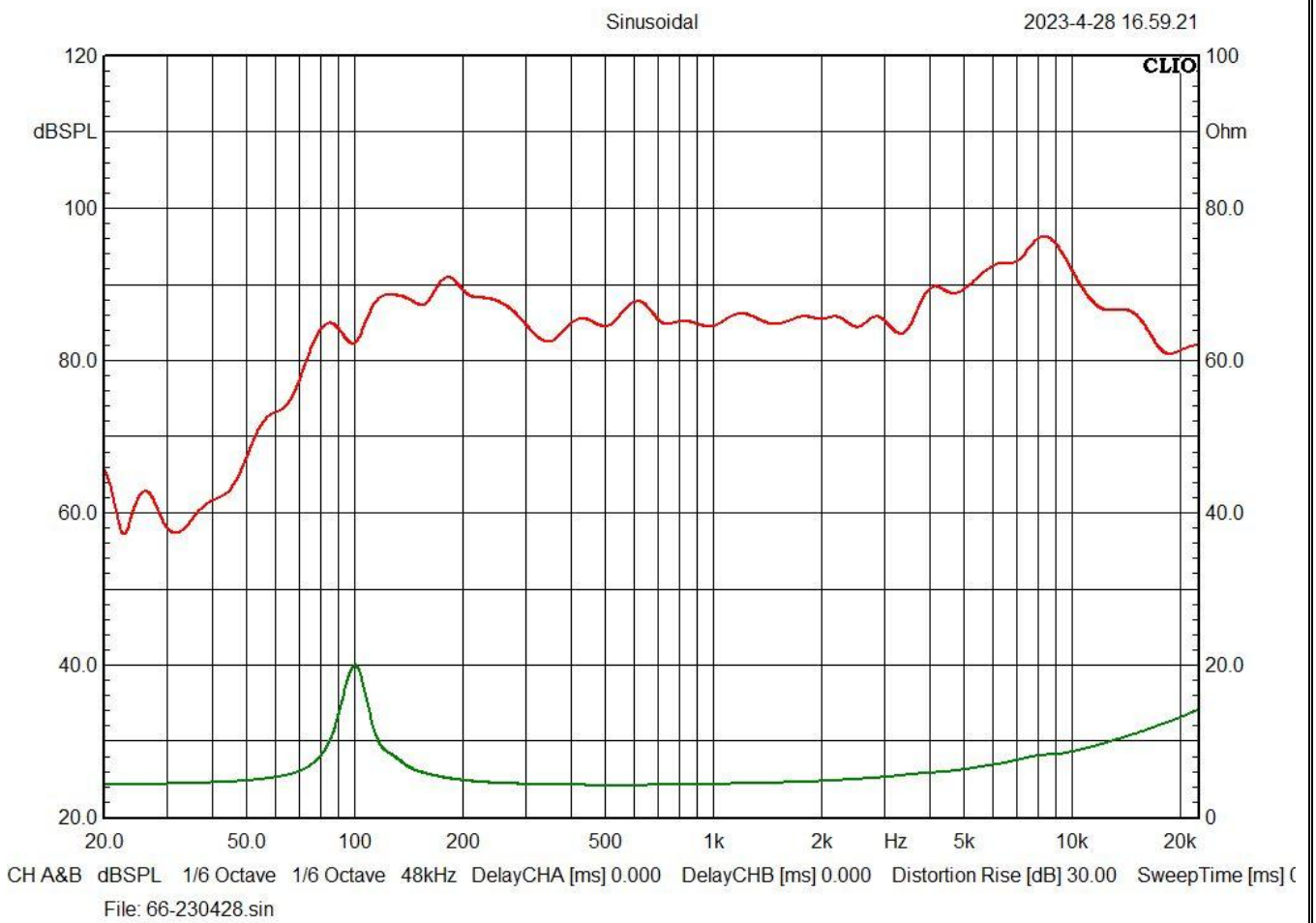

19. APPEARANCE DRAWING 外观尺寸图

--	--	--	--

REVISIONS 版本号	变更内容	E.C.N.O 设变番号	BY / DATE 签名/日期
A			
B			

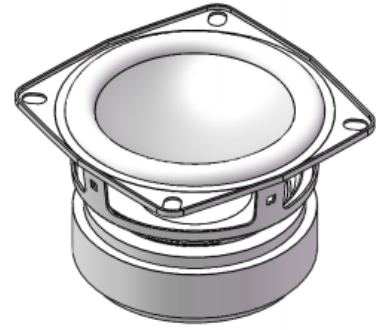
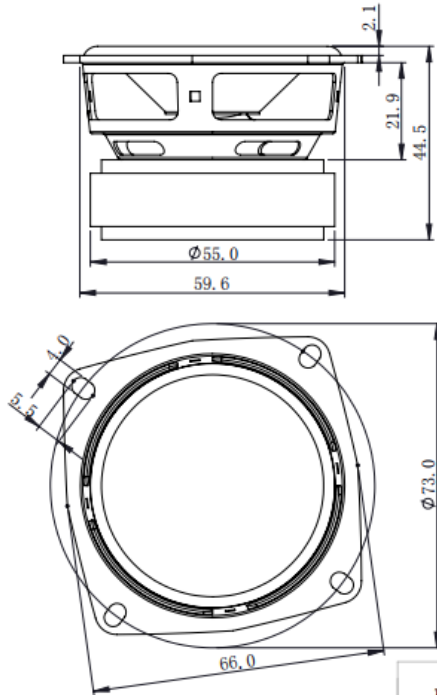

公差 TOLERANCE	材质 Material	处理 Treatment	重量 Weight	单位 Unit	比例	投影法		
0~6以下 ±0.1				mm				
6~30以下 ±0.2	承认 APPR BY	审核 CHECK BY	验证 VALIDATE BY	绘图 DRAWN BY	名称			
30~100以下 ±0.3					图号		版本	NR
100~300以下 ±0.5								
角度公差±1°								

公差 TOL	如图	单位 UNIT	mm					顾客 CUSTOMER			
重量 N. G		比例 SCALE	1:1					机种名称 PART NO.	H66FW1604-01		
	日期 DATE	说明 REVISE	日期 DATE	2023-04-28	版本号	0	图番 DRAWING NO.				
1.								核准	审核	制图	
2.											
3.											