



HITANO ENTERPRISE CORP.

7F-7, No. 3, Wu Chuan 1st Road, New Taipei
 Industrial Park, New Taipei City, TAIWAN, R.O.C.
 Tel: +886 2 2299 1331 Fax: +886 2 2298 2466

Data Sheet

Customer: _____

Product : Automotive Grade Anti-Sulfurated Thick Film Array ChipResistor
 – HAS 42 / AS43 / AS21 / AS41

Size: 0402x4 / 0603x4 / 0201x2 / 0201x4

Issued Date: 15-Jun-22

Edition : REV.A3

Record of change

Date	Ver.	Description	Page

VENDOR :

HITANO ENTERPRISE CORP.

7F-7,NO.3,WUCHUAN1ST ROAD,
 NEW TAIPEI INDUSTRIAL PARK,
 NEW TAIPEI CITY, TAIWAN, R.O.C.
 TEL:+886222991331(REP.)
 FAX:+886222982466



MAKER :

VIKING TECH CORPORATION

No.70, Guangfu N. Rad., Hsin Chu Industrial Park,
 Hukou Hsiang, Hsin Chu Hsien, 303, Taiwan
 TEL:886-3-5972931
 FAX:886-3-5972935•886-3-5973494



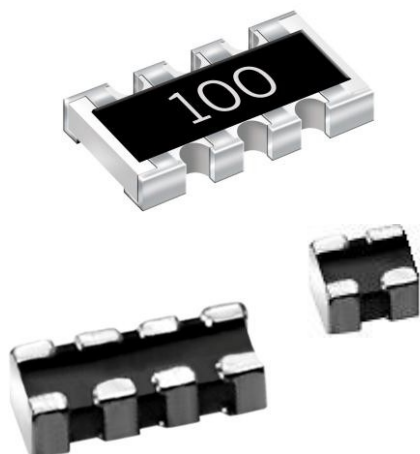

■ **Scope**

– This specification applies to all sizes of rectangular-type fixed chip resistors with Ruthenium-base as material.

■ **Features**

- Special construction to prevent sulfuration in a sulfur containing environment
- Reduction of assembly costs and matching with placement machines
- Reliability, high quality
- Suitable for IR reflow soldering
- AEC-Q200 Compliance
- 100% CCD inspection

■ **Construction**

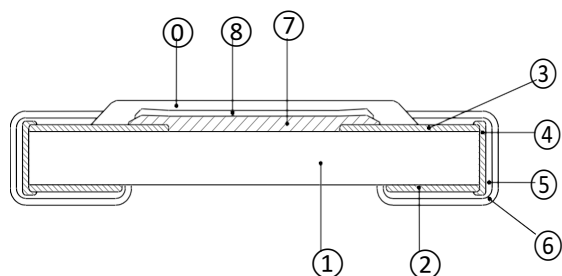

■ **Applications**

- High-end Computer
- Industrial Equipment
- Automatic Equipment Controller
- Medical Equipment
- High-end Multimedia Electronics
- Outdoor Electronic Applications

① Alumina Substrate	④ Edge Electrode	⑦ Resistor Layer
② Bottom Electrode	⑤ Barrier Layer	⑧ Primary Overcoat
③ Top Electrode	⑥ External Electrode	⑩ Secondary Overcoat

■ **Equivalent Circuit Diagram**

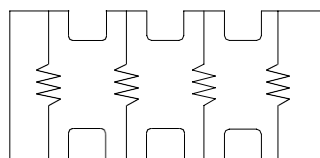

AS42/AS43

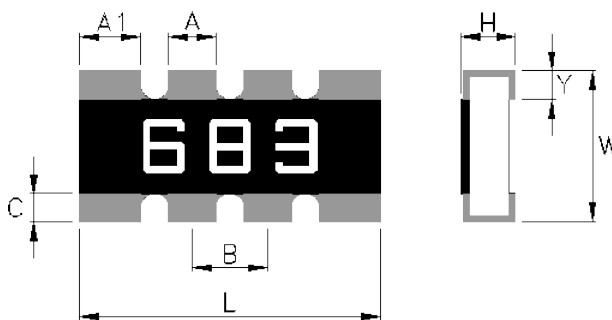

■ **Dimensions**

Type	Number of Resistors	L (mm)	W (mm)	H (mm)	A1 (mm)	A (mm)	B (mm)	C (mm)	Y (mm)	Weight (g) (1000pcs)
HAS43	4	3.20±0.15	1.60±0.15	0.55±0.10	0.60±0.10	0.50±0.15	0.80±0.05	0.30±0.15	0.30±0.15	8.6
HAS42	4	2.00±0.10	1.00±0.10	0.45±0.10	0.40±0.10	0.30±0.10	0.50±0.05	0.22±0.15	0.22±0.15	3.1

**** If you have any request not find from above datas, please contact our sales for further information, we may do our best to meet your request.**

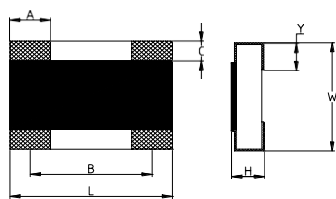

AS21

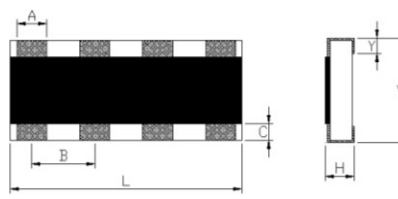

AS41

Type	Number of Resistors	L (mm)	W (mm)	H (mm)	A (mm)	B (mm)	C (mm)	Y (mm)	Weight (g) (1000pcs)
HAS21	2	0.80±0.10	0.60±0.10	0.35±0.10	0.30±0.10	0.50±0.10	0.15±0.10	0.15±0.10	0.5
HAS41	4	1.40±0.10	0.60±0.10	0.35±0.10	0.20±0.10	0.40±0.10	0.10±0.07	0.15±0.05	0.8

Part Numbering

HAS	43	J	T	F	1000	A
Product Type	Dimensions	Resistance Tolerance	Packaging Code	TCR (PPM/°C)	Resistance	Making
	43: 0603x4 42: 0402x4 21: 0201x2 41: 0201x4	J: ±5% F: ±1%	T: 7" Taping Reel V: 10" Taping Reel W: 13" Taping Reel	F: ±200	1000: 100Ω 1002: 10KΩ 2201: 2.2KΩ 1003: 100KΩ	A: Automotive Grade

Recommend Land Pattern

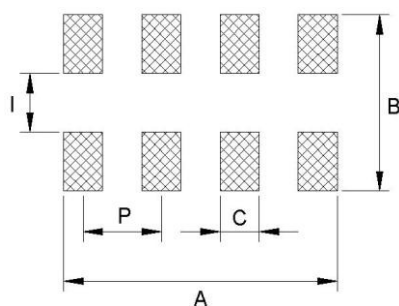

Type	A (mm)	B (mm)	C (mm)	I (mm)	P (mm)
HAS43	3.10	2.85	0.45	0.80	0.80
HAS42	2.10	1.80	0.30	0.50	0.50
HAS21	0.80	0.90	--	0.30	0.50
HAS41	1.40	0.90	0.20	0.30	0.40

Derating Curve

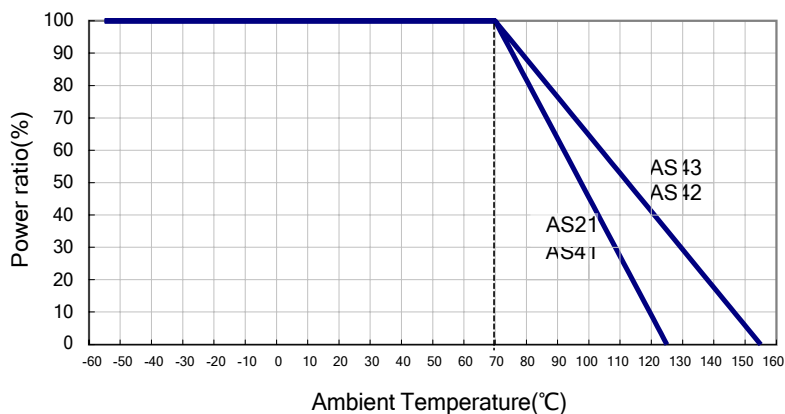

■ Soldering Condition (Ref. IPC/JEDEC J-STD-020 & J-STD-002)

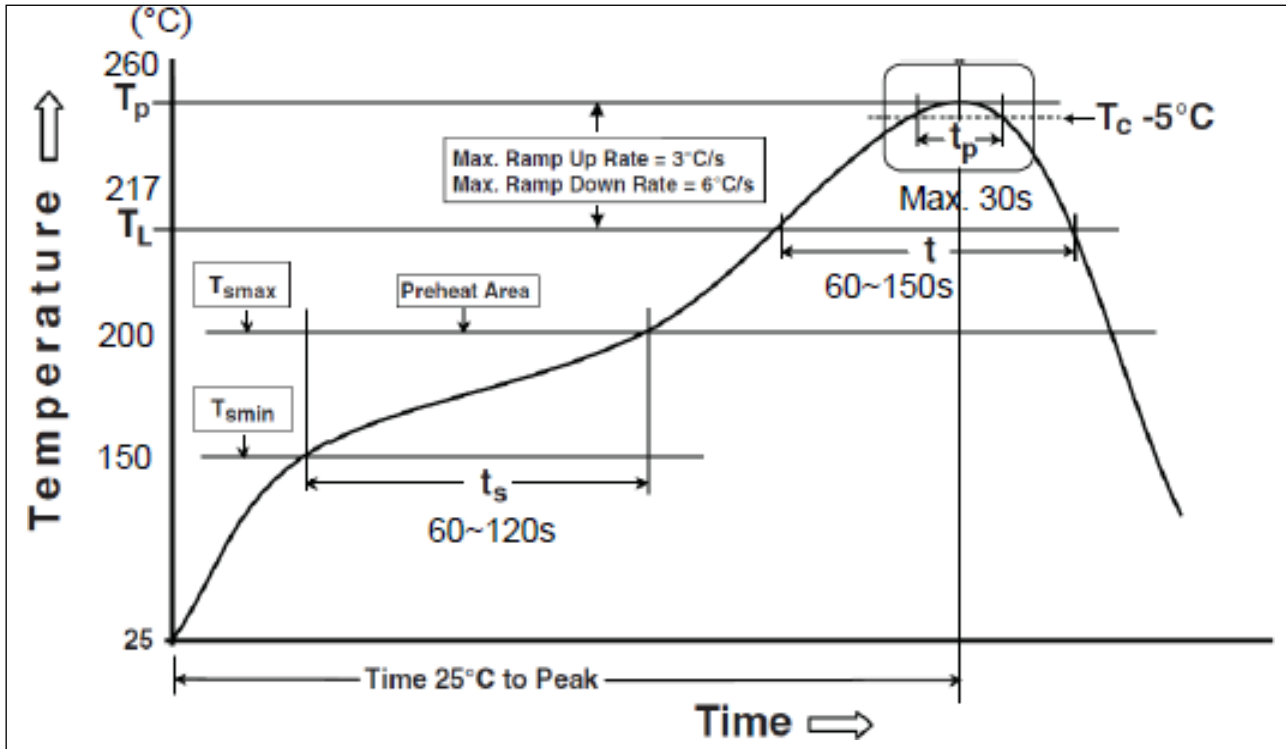

Reflow Profiles	
Profile Feature	Pb-Free Assembly
Preheat Min. Temperature (T _{smin}) Max Temperature (T _{smax}) Preheating time (t _s) from (T _{smin} to T _{smax})	150 °C 200 °C 60-120 seconds
Ramp-up rate (T _L to T _p)	3 °C/second max.
Liquidous temperature (T _L) Time (t _L) maintained above T _L	217 °C 60-150 seconds
Min. Peak temperature (T _p min)	235°C
Max. Peak temperature (T _p max)	260°C
Time (t _p) within 5 °C of the specified classification temperature (T _c)	30 seconds max.
Ramp-down rate (T _p to T _L)	6 °C/second max.
Time 25 °C to peak temperature	8 minutes max.

■ Standard Electrical Specifications

Item Type	Power Rating at 70°C Jumper Rated Current	Operating Temp. Range	Max. Operating Voltage	Max. Overload Voltage	Number of Resistors	Resistance Range		TCR (PPM/°C)
						±1%	±5%	
HAS43	1/10W	-55 ~ +155°C	50V	100V	4	10Ω - 1MΩ	1Ω - 1MΩ	±200
HAS42	1/16W	-55 ~ +155°C	25V	50V	4	10Ω - 1MΩ	1Ω - 1MΩ	±200
HAS21	1/32W	-55 ~ +125°C	12.5V	25V	2	-	3Ω - 9.1Ω	±300
						10Ω - 1MΩ		±200
HAS41	1/32W	-55 ~ +125°C	12.5V	25V	4	10Ω - 1MΩ		±200

Operating Voltage= $\sqrt{P \cdot R}$ or Max. Operating Voltage listed above, whichever is lower.

Overload Voltage= $2.5 \cdot \sqrt{P \cdot R}$ or Max. Overload Voltage listed above, whichever is lower.

■ Viking is capable of manufacturing the optional spec based on customer's requirement.

■ Environmental Characteristics

Item	Requirement		Test Method
	±1%	±5%	
Temperature Coefficient of Resistance (T.C.R.)	As Spec.		JIS-C-5201-1 4.8 IEC-60115-1 4.8 At 25°C/-55°C and 25°C/+125°C, 25°C is the reference temperature
Short Time Overload	$\pm(1.0\%+0.05\Omega)$	$\pm(2.0\%+0.05\Omega)$	JIS-C-5201-1 4.13 IEC-60115-1 4.13 RCWV*2.5 or Max. Overload Voltage whichever is lower for 5 seconds
Insulation Resistance	$\geq 10G$		JIS-C-5201-1 4.6 IEC-60115-1 4.6 Max. Overload Voltage for 1 minute
Operational Life	$\pm(2.0\%+0.10\Omega)$	$\pm(3.0\%+0.10\Omega)$	MIL-STD-202 Method 108 Condition D Steady State TA=125°C at derated power Measurement at 24±4 hours after test conclusion.
Biased Humidity	$\pm(2.0\%+0.10\Omega)$	$\pm(3.0\%+0.10\Omega)$	MIL-STD-202 Method 103 1000 hrs 85°C/85%RH 10% of operating power ($\leq 100V$)
High Temperature Exposure	$\pm(1.0\%+0.05\Omega)$	$\pm(1.5\%+0.10\Omega)$	MIL-STD-202 Method 108 at +155°C/+125°C for 1000 hrs
Board Flex	$\pm(1.0\%+0.05\Omega)$	$\pm(1.0\%+0.05\Omega)$	AEC-Q200-005 Bending once for 60 seconds with 3mm
Solderability	95% min. coverage		JIS-C-5201-1 4.17 IEC-60115-1 4.17 245±5°C for 3 seconds
Resistance to Soldering Heat	$\pm(0.5\%+0.05\Omega)$	$\pm(1.0\%+0.05\Omega)$	MIL-STD-202 Method 210 260±5°C for 10 seconds
Voltage Proof	No breakdown or flashover		JIS-C-5201-1 4.7 IEC-60115-1 4.7 1.42 times Max. Operating Voltage for 1 minute

Item	Requirement		Test Method
	±1%	±5%	
Leaching	Individual leaching area ≤5% Total leaching area ≤ 10%		JIS-C-5201-1 4.18 IEC-60068-2-58 8.2.1 260±5°C for 30 seconds
Temperature Cycling	±(0.5%+0.05Ω)	±(1.5%+0.05Ω)	JESD22 Method JA-104 -55°C to +125°C, 1000 cycles
Mechanical Shock	±(0.25%+0.05Ω)	±(1.0%+0.05Ω)	MIL-STD-202 Method 213 Wave Form: Tolerance for half sine shock pulse. Peak value is 100g's. Normal duration (D) is 6.
Vibration	±(0.5%+0.05Ω)	±(1.0%+0.05Ω)	MIL-STD-202 Method 204 5 g's for 20 min., 12 cycles each of 3 orientations, 10-2000 Hz
ESD	±(1%+0.05Ω)		AEC-Q200-002 Human body, 0.5KV
Resistance to Solvents	No visible damage on appearance and marking.		MIL-STD-202 Method 215 Add Aqueous wash chemical - OKEM Clean or equivalent. Do not use banned solvents.
Terminal Strength	No broken		AEC-Q200-006 Force of 1.8kg for 60 seconds.
Flammability	No ignition of the tissue paper or scorching of the pinewood board		UL-94 V-0 or V-1 are acceptable. Electrical test not required.
Sulfur Test	ΔR±1%	ΔR±5%	EIA-977 (Condition B) 105±2°C, no power rating for 750 hrs.

RCWV(Rated Continuous Working Voltage)=√(P*R) or Max. Operating Voltage whichever is lower.

■ **Storage Temperature: 15~28°C; Humidity < 80%RH**

■ **Shelf Life: 2 years from production date.**

■ Packaging

Reel Specifications & Packaging Quantity

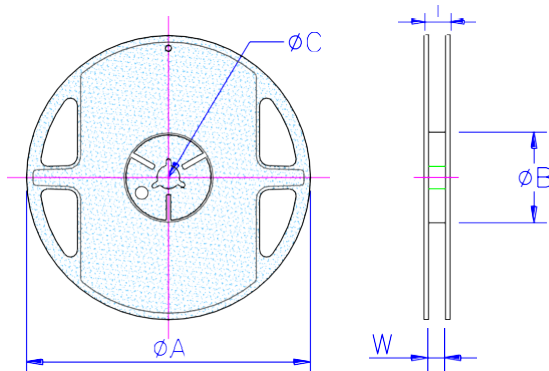

Type	Packaging Quantity	Tape Width	Reel Diameter	ΦA (mm)	ΦB (mm)	ΦC (mm)	W (mm)	T (mm)	
HAS43	Paper	5K	8mm	7 inch	178.5±1.5	60 ^{+1/-0}	13.0±0.2	9.0±0.5	12.5±0.5
		10K	8mm	10 inch	254±1.0	100±0.5	13.0±0.2	9.5±0.5	13.5±0.5
		20K	8mm	13 inch	330±1.0	100±0.5	13.0±0.2	9.5±0.5	13.5±0.5
HAS42	Paper	10K	8mm	7 inch	178.5±1.5	60 ^{+1/-0}	13.0±0.2	9.0±0.5	12.5±0.5
		20K	8mm	10 inch	254±1.0	100±0.5	13.0±0.2	9.5±0.5	13.5±0.5
		40K	8mm	13 inch	330±1.0	100±0.5	13.0±0.2	9.5±0.5	13.5±0.5
HAS21 HAS41	Paper	10K	8mm	7 inch	178.5±1.5	60 ^{+1/-0}	13.0±0.2	9.0±0.5	12.5±0.5

Paper Tape Specifications

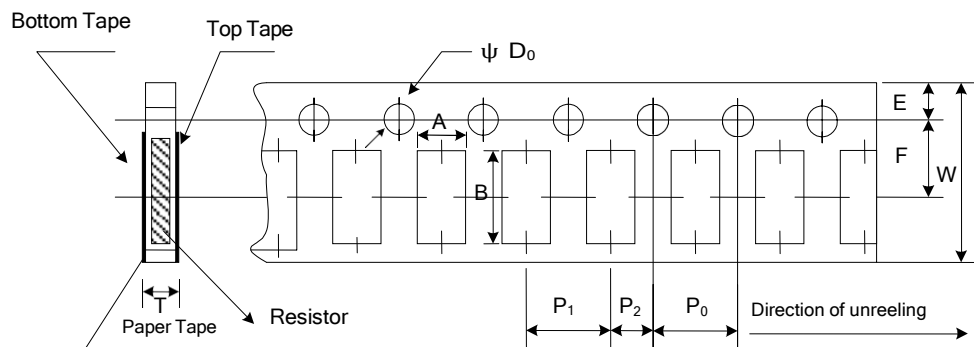

Type	A (mm)	B (mm)	W (mm)	E (mm)	F (mm)	P ₀ (mm)	P ₁ (mm)	P ₂ (mm)	ΦD ₀ (mm)	T (mm)
HAS43	1.95±0.1	3.50±0.1	8.0±0.2	1.75±0.1	3.5±0.05	4.0±0.1	4.0±0.05	2.0±0.05	1.50+0.1,-0	0.85±0.1
HAS42	1.20±0.1	2.20±0.1	8.0±0.2	1.75±0.1	3.5±0.05	4.0±0.1	2.0±0.05	2.0±0.05	1.50+0.1,-0	0.70±0.1
HAS21	0.77±0.05	0.97±0.05	8.0±0.2	1.75±0.1	3.5±0.05	4.0±0.1	2.0±0.05	2.0±0.05	1.50+0.1,-0	0.50±0.1
HAS41	0.77±0.05	1.57±0.05	8.0±0.2	1.75±0.1	3.5±0.05	4.0±0.1	2.0±0.05	2.0±0.05	1.50+0.1,-0	0.50±0.1

■ **Marking**

No Marking for AS21/AS41

1% for AS43 & AS42: 4 digits marking (non-including E24 series)

Example:

Resistance	102Ω	2.49KΩ	49.9KΩ	121KΩ
marking	1020	2491	4992	1213

1% & 5% for AS43 & AS42: 3 digits marking in E24

Example: 101=100Ω 102=1KΩ (1st and 2nd are E24 code and 3rd code is multiplier)

E24 code	10	11	12	13	15	16	18	20	22	24	27	30	33	36	39	43	47	51	56	62	68	75	82	91
----------	----	----	----	----	----	----	----	----	----	----	----	----	----	----	----	----	----	----	----	----	----	----	----	----



HAS series.

Automotive Grade Anti-Sulfurated Thick Film Array Chip Resistor

REVISION HISTORY

REVISION	DATE	CHANGE NOTIFICATION	DESCRIPTION
Version A	Mar 10, 21	-	- New product release
Version A1	Nov 15, 2021	-	- Increase the shelf life description
Version A2	Feb 15, 2022	-	- Derating Curve changes the temperature range
Version A3	Jun 15, 2022	-	- Modify Soldering Condition