



HITANO ENTERPRISE CORP.

7F-7, No. 3, Wu Chuan 1st Road, New Taipei
 Industrial Park, New Taipei City, TAIWAN, R.O.C.
 Tel: +886 2 2299 1331 Fax: +886 2 2298 2466

Data Sheet

Customer: _____

Product : Automotive Grade Metal Film Precision High Voltage
 MELF Resistor - HCSR Series (Brown)

Size: 0204/0207

Issued Date: 16-Nov-22

Edition : REV.A6

Record of change

Date	Ver.	Description	Page

VENDOR :

HITANO ENTERPRISE CORP.

7F-7,NO.3,WUCHUAN1ST ROAD,
 NEW TAIPEI INDUSTRIAL PARK,
 NEW TAIPEI CITY, TAIWAN, R.O.C.
 TEL:+886222991331(REP.)
 FAX:+886222982466



MAKER :

VIKING TECH CORPORATION

No.70, Guangfu N. Rad., Hsin Chu Industrial Park,
 Hukou Hsiang, Hsin Chu Hsien, 303, Taiwan
 TEL:886-3-5972931
 FAX:886-3-5972935•886-3-5973494



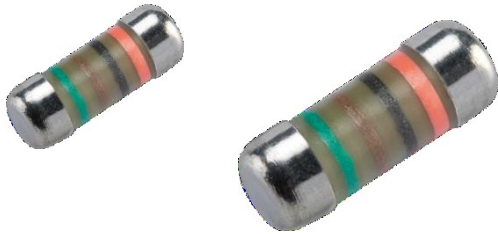

■ **Features**

- AEC-Q200 Compliance
- Thin film technology
- High voltage application
- Sn termination on Ni barrier layer
- Tight tolerance down to $\pm 0.1\%$
- High power rating up to 1 Watts
- SMD enabled structure
- Lead-free and RoHS compliant

■ **Applications**

- Industrial
- Telecommunication
- Medical Equipment
- Measurement/Testing Equipment

TECHNICAL SPECIFICATIONS		
DESCRIPTION	HCSR0204	HCSR0207
Resistance range	340K Ω -10M Ω	340K Ω -10M Ω
Resistance tolerance	$\pm 1\%$; $\pm 0.5\%$; $\pm 0.25\%$; $\pm 0.1\%$	
Temperature coefficient	$\pm 50\text{ppm}/^\circ\text{C}$; $\pm 25\text{ppm}/^\circ\text{C}$	
Power rating P ₇₀	2/5W	1W
Operating voltage U _{max.}	500V	1000V
Operating temperature range	-55 $^\circ\text{C}$ ~155 $^\circ\text{C}$	
Max. resistance change at P70 for resistance range, $\Delta R/R$ max., after 1000 h	$\leq 0.5\%$	$\leq 0.5\%$

■ **Construction & Dimension**

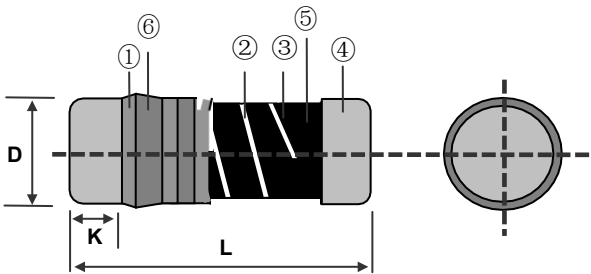

Type	L (mm)	ΦD (mm)	K (mm)	Weight 1,000EA (g)
HCSR0204	3.50 ± 0.2	1.40 ± 0.15	0.8 ± 0.1	18.7
HCSR0207	5.90 ± 0.2	2.20 ± 0.20	1.3 ± 0.1	80.9

① Insulation Coating	④ Electrode Cap
② Trimming Line	⑤ Resistor Layer
③ Ceramic Rod	⑥ Marking

**** If you have any request not find from above datas, please contact our sales for further information, we may do our best to meet your request.**

■ Part Numbering

Part Number: **CSRP0204FTDG1004**

H	C	S	R	P	0	2	0	4	D	T	D	G	1	0	0	4
Product Type	Dimensions (L×ΦD)		Resistance Tolerance		Packaging Code		TCR (PPM/°C)		Power Rating		Resistance					
HCSRP	0204: 3.5x1.4 0207: 5.9x2.2		B: ±0.1% C: ±0.25% D: ±0.5% F: ±1%		T: 7" Taping Reel S: 7" Taping Reel, Antistatic Tape W: 13" Taping Reel M: 13" Taping Reel, Antistatic Tape		C: ±25 D: ±50		T: 1W G: 2/5W		1004: 1MΩ					

*Packaging Code "S" & "M" only for 0204 size products.

■ Recommend Land Pattern

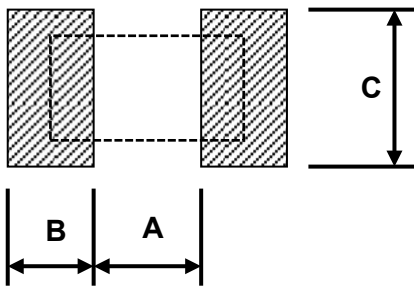

Type	A (mm)	B (mm)	C (mm)
HCSRP0204	1.6	1.2	1.6
HCSRP0207	3.0	1.7	2.4

■ Derating Curve

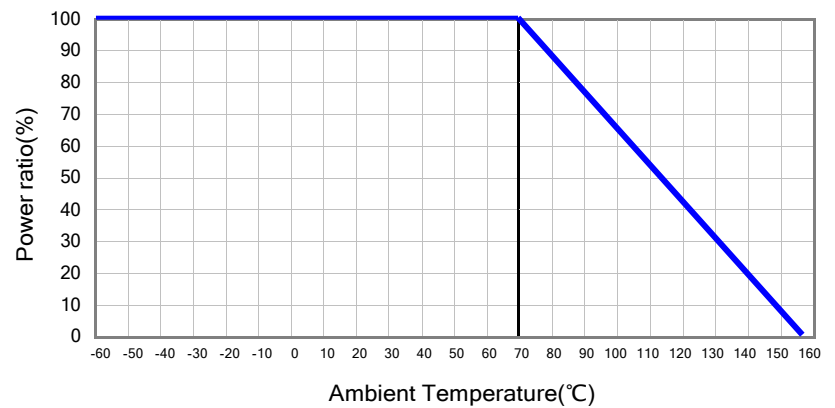

■ Soldering Condition (Ref. IPC/JEDEC J-STD-020 & J-STD-002)

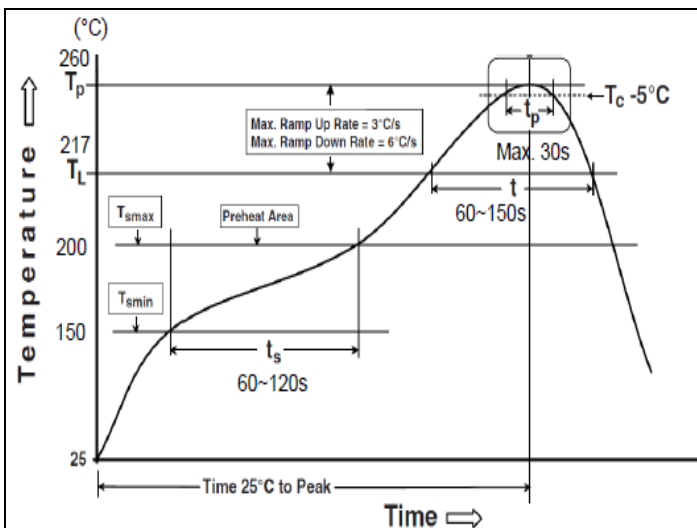

Reflow Profiles	
Profile Feature	Pb-Free Assembly
Preheat	
Min. Temperature (T _{sm})	150 °C
Max Temperature (T _{sm})	200 °C
Preheating time (t _s) from (T _{sm} to T _{sm})	60-120 seconds
Ramp-up rate (T _L to T _p)	3 °C/second max.
Liquidous temperature (T _L)	217 °C
Time (t _L) maintained above T _L	60-150 seconds
Min. Peak temperature (T _p min)	235°C
Max. Peak temperature (T _p max)	260°C
Time (t _p) within 5 °C of the specified classification temperature (T _c)	30 seconds max.
Ramp-down rate (T _p to T _L)	6 °C/second max.
Time 25 °C to peak temperature	8 minutes max.

■ Electrical Specifications

Item Type	Power Rating at 70°C	Operating Temp. Range	Max. Operating Voltage	Max. Overload Voltage	Resistance Range				TCR (PPM/°C)
					±0.1% (E24,E96)	±0.25% (E24,E96)	±0.5% (E24,E96)	±1% (E24,E96)	
0204	2/5W	-55 ~ +155°C	500V	1000V	340KΩ-1MΩ		340KΩ-3.4MΩ		±25
					340KΩ-1MΩ		340KΩ-3.4MΩ	340KΩ-10MΩ	±50
0207	1W	-55 ~ +155°C	1000V	2000V	340KΩ-1MΩ		340KΩ-3.4MΩ		±25
					340KΩ-1MΩ		340KΩ-3.4MΩ	340KΩ-10MΩ	±50

Operating Voltage= $\sqrt{P \cdot R}$ or Max. Operating Voltage listed above, whichever is lower.

Overload Voltage= $2.5 \cdot \sqrt{P \cdot R}$ or Max. Overload Voltage listed above, whichever is lower.

RCWV(Rated Continuous Working Voltage)= $\sqrt{P \cdot R}$ or Max. Operating Voltage whichever is lower.

■ Viking is capable of manufacturing the optional spec based on customer's requirement.

■ Environmental Characteristics

Item	Requirement	Test Method
Temperature Coefficient of Resistance (T.C.R.)	As Spec	JIS-C-5201-1 4.8 IEC-60115-1 4.8 At 25°C/-55°C and 25°C/+125°C, 25°C is the reference temperature
Short Time Overload	±(0.15%+0.05Ω)	JIS-C-5201-1 4.13 IEC-60115-1 4.13 RCWV*2.5 or Max. Overload Voltage whichever is lower for 5 seconds
Insulation Resistance	≥10G	JIS-C-5201-1 4.6 IEC-60115-1 4.6 Max. Overload Voltage for 1 minute
Endurance	±(0.5%+0.05Ω)	JIS-C-5201-1 4.25 IEC-60115-1 4.25.1 MIL-STD-202 Method 108 70±2°C, RCWV for 1000 hrs with 1.5 hrs "ON" and 0.5 hr "OFF"
Biased Humidity	≤3.4MΩ: ±(1%+0.05Ω) >3.4MΩ: ±(2%+0.05Ω)	MIL-STD-202 Method 103 1344 hrs 85°C/85%RH 10% of operating power. (≤100 V)
High Temperature Exposure	±(1%+0.05Ω)	MIL-STD-202 Method 108 at +155°C for 1000 hrs
Board Flex	±(0.5%+0.05Ω)	AEC-Q200-005 Bending once for 60 seconds with 2mm
Solderability	95% min. coverage	JIS-C-5201-1 4.17 IEC-60115-1 4.17 J-STD-002 245±5°C for 3 seconds
Resistance to Soldering Heat	±(0.25%+0.05Ω)	MIL-STD-202 Method 210 260±5°C for 10 seconds
Voltage Proof	No breakdown or flashover	JIS-C-5201-1 4.7 IEC-60115-1 4.7 1.42 times Max. Operating Voltage for 1 minute
Leaching	Individual leaching area ≤5% Total leaching area ≤ 10%	JIS-C-5201-1 4.18 IEC-60068-2-58 8.2.1 260±5°C for 30 seconds
Temperature Cycling	±(0.5%+0.05Ω)	JESD22 Method JA-104 -55°C to +125°C, 1000 cycles

Item	Requirement	Test Method
Resistance to Solvents	No visible damage on appearance and marking.	MIL-STD-202 Method 215 Add Aqueous wash chemical - OKEM Clean or equivalent. Do not use banned solvents.
Mechanical Shock	$\pm(0.25\%+0.01\Omega)$	MIL-STD-202 Method 213 Wave Form: Tolerance for half sine shock pulse. Peak value is 100g's. Normal duration (D) is 6.
Vibration	$\pm(0.5\%+0.01\Omega)$	MIL-STD-202 Method 204 5 g's for 20 min., 12 cycles each of 3 orientations, 10-2000 Hz
ESD	$\pm(0.5\%+0.01\Omega)$	AEC-Q200-002 Human body, 0204:2KV; 0207:4KV
Terminal Strength	No broken	AEC-Q200-006 Force of 1.8kg for 60 seconds.
Flammability	No ignition of the tissue paper or scorching or the pinewood board	UL-94 V-0 or V-1 are acceptable. Electrical test not required.

RCWV(Rated Continuous Working Voltage)= $\sqrt{P \cdot R}$ or Max. Operating Voltage whichever is lower.

■ **Storage Temperature: 15~28°C; Humidity < 80%RH**

■ **Shelf Life: 2 years from production date.**

■ Packaging

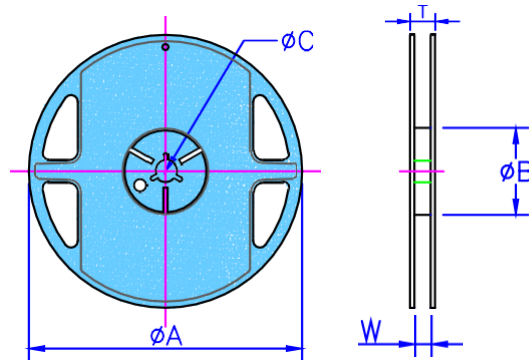

Packaging Quantity & Reel Specifications

Type	Reel Diameter	ΦA (mm)	ΦB (mm)	ΦC (mm)	W (mm)	T (mm)	Emboss Plastic Tape (EA)
HCSR0204	7 inch	178.5±1.5	60.0+1.0	13.0±0.2	9.0±0.5	12.5±0.5	3,000
	13 inch	330±1.0	100±0.5	13.0±0.2	9.5±0.5	13.5±0.5	10,000
HCSR0207	7 inch	178.5±1.5	60.0+1.0	13.0±0.5	13.0±0.5	15.5±0.5	2,000
	13 inch	330±1.0	99±0.5	13.5±0.5	13.4±1	17.8±1	6,000

Emboss Plastic Tape Specifications

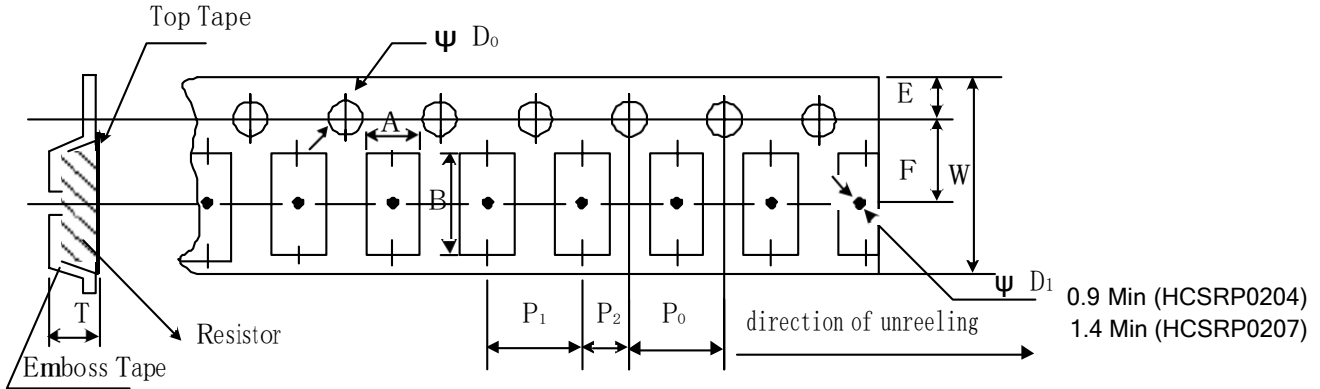

Type	A (mm)	B (mm)	W (mm)	E (mm)	F (mm)	P ₀ (mm)	P ₁ (mm)	P ₂ (mm)	ΦD ₀ (mm)	T (mm)
HCSR P0204	1.55±0.20	3.65±0.20	8.0±0.10	1.75±0.10	3.50±0.05	4.00±0.10	4.00±0.10	2.00±0.05	1.50+0.10	1.80±0.10
HCSR P0207	2.40±0.10	6.15±0.10	12.0±0.10	1.75±0.10	5.50±0.05	4.00±0.10	4.00±0.10	2.00±0.05	1.50+0.10	2.70±0.10

Lightning Surge

Resistors are tested in accordance with IEC 60115-1 using both 1.2/50us and 10/700us pulse shapes. The limit of acceptance is a shift in resistance of less than 0.5% from the initial value.

1.2/50µs Lightning Surge

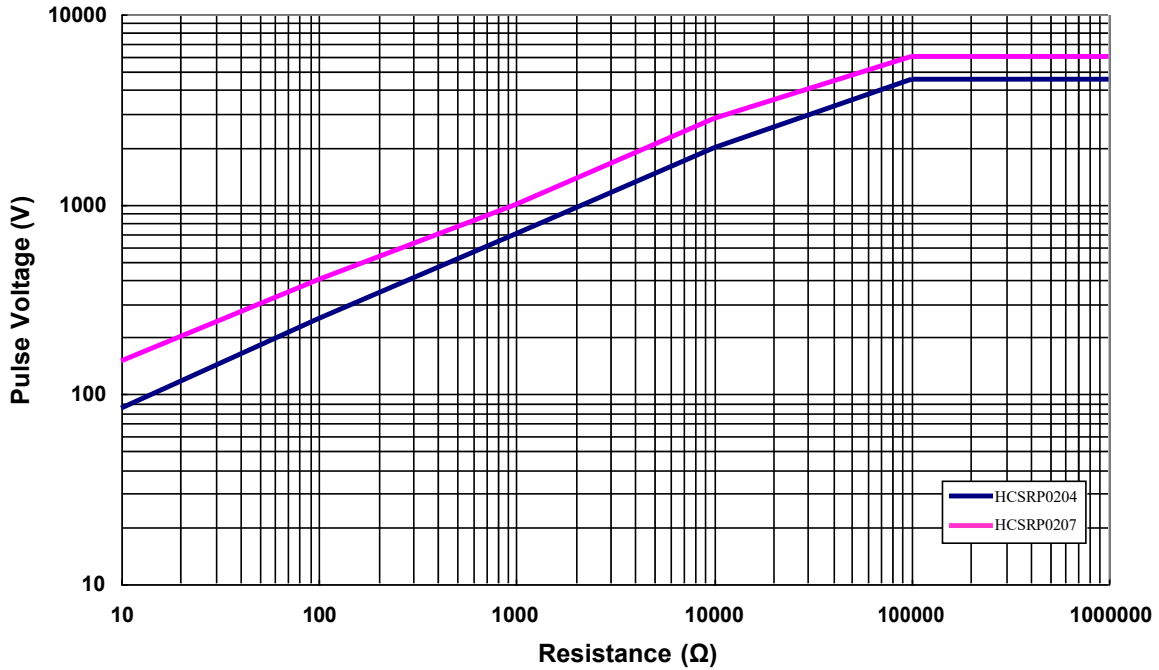

10/700µs Lightning Surge

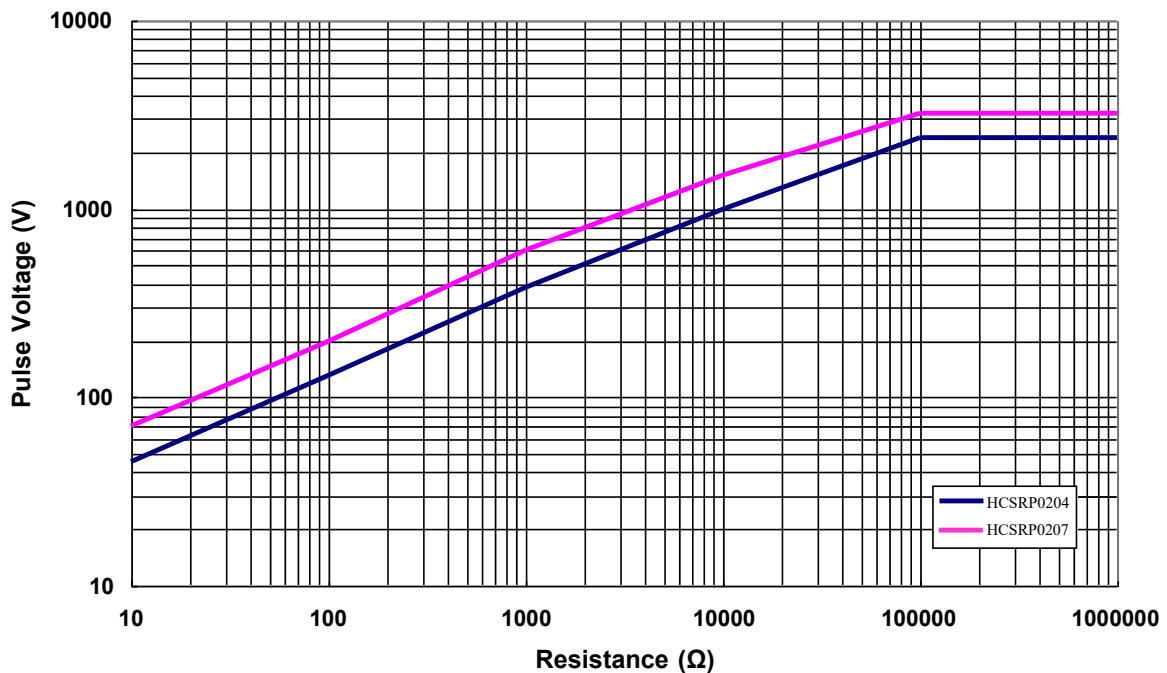

Marking & Resistance Tolerance

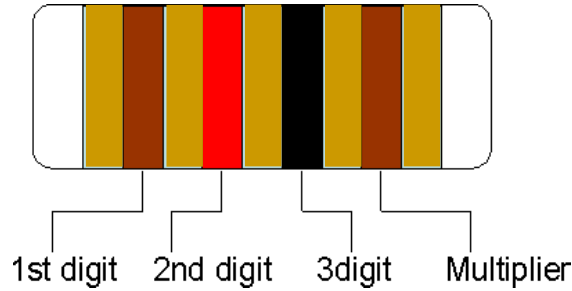

±1%	E-24	1.0	1.1	1.2	1.3	1.5	1.6	1.8	2.0	2.2	2.4	2.7	3.0	3.3	3.6	3.9	4.3	4.7	5.1	5.6	6.2	6.8	7.5	8.2	9.1
	E-96	1.00	1.02	1.05	1.07	1.10	1.13	1.15	1.18	1.21	1.24	1.27	1.30	1.33	1.37	1.40	1.43	1.47	1.50	1.54	1.58	1.62	1.65	1.69	1.74
		1.78	1.82	1.87	1.91	1.96	2.00	2.05	2.10	2.15	2.21	2.26	2.32	2.37	2.43	2.49	2.55	2.61	2.67	2.74	2.80	2.87	2.94	3.01	3.09
		3.16	3.24	3.32	3.40	3.48	3.57	3.65	3.74	3.83	3.92	4.02	4.12	4.22	4.32	4.42	4.53	4.64	4.75	4.87	4.99	5.11	5.23	5.36	5.49
		5.62	5.76	5.90	6.04	6.19	6.34	6.49	6.65	6.81	6.98	7.15	7.32	7.50	7.68	7.87	8.06	8.25	8.45	8.66	8.87	9.09	9.31	9.53	9.76
±0.5% ±0.25% ±0.1%	E-192	10.0	10.1	10.2	10.4	10.5	10.6	10.7	10.9	11.0	11.1	11.3	11.4	11.5	11.7	11.8	12.0	12.1	12.3	12.4	12.6	12.7	12.9	13.0	13.2
		13.3	13.5	13.7	13.8	14.0	14.2	14.3	14.5	14.7	14.9	15.0	15.2	15.4	15.6	15.8	16.0	16.2	16.4	16.5	16.7	16.9	17.2	17.4	17.6
		17.8	18.0	18.2	18.4	18.7	18.9	19.1	19.3	19.6	19.8	20.0	20.3	20.5	20.8	21.0	21.3	21.5	21.8	22.1	22.3	22.6	22.9	23.2	23.4
		23.7	24.0	24.3	24.6	24.9	25.2	25.5	25.8	26.1	26.4	26.7	27.1	27.4	27.7	28.0	28.4	28.7	29.1	29.4	29.8	30.1	30.5	30.9	31.2
		31.6	32.0	32.4	32.8	33.2	33.6	34.0	34.4	34.8	35.2	35.7	36.1	36.5	37.0	37.4	37.9	38.3	38.8	39.2	39.7	40.2	40.7	41.2	41.7
		42.2	42.7	43.2	43.7	44.2	44.8	45.3	45.9	46.4	47.0	47.5	48.1	48.7	49.3	49.9	50.5	51.1	51.7	52.3	53.0	53.6	54.2	54.9	55.6
		56.2	56.9	57.6	58.3	59.0	59.7	60.4	61.2	61.9	62.6	63.4	64.2	64.9	65.7	66.5	67.3	68.1	69.0	69.8	70.6	71.5	72.3	73.2	74.1
		75.0	75.9	76.8	77.7	78.7	79.6	80.6	81.6	82.5	83.5	84.5	85.6	86.6	87.6	88.7	89.8	90.9	92.0	93.1	94.2	95.3	96.5	97.6	98.8

Color	Digit	Multiplier
Silver	-	10 ⁻²
Gold	-	10 ⁻¹
Black	0	10 ⁰
Brown	1	10 ¹
Red	2	10 ²
Orange	3	10 ³
Yellow	4	10 ⁴
Green	5	10 ⁵
Blue	6	10 ⁶
Violet	7	10 ⁷
Grey	8	10 ⁸
White	9	10 ⁹



HCSR^P series.

Automotive Grade Metal Film Precision High Voltage MELF Resistor

REVISION HISTORY

REVISION	DATE	CHANGE NOTIFICATION	DESCRIPTION
Version A	Oct 13, 2017	-	- Develop a new specification
Version A1	May 20, 2019	-	- Modify TCR Test description
Version A2	Mar 10, 2021	-	- Modify Soldering Condition (IPC/JEDEC J-STD-020)
Version A3	Dec 21, 2021	PCN #: 210602	- Expand the resistance range to 10M - Newly added antistatic tape packaging method - Change the paint color of the body to brown
Version A4	Feb 15, 2022	-	- Derating Curve changes the temperature range
Version A5	Jun 15, 2022	-	- Modify Soldering Condition
Version A6	Nov 16, 2022	-	- Modify Endurance Spec.