

METAL FILM RESISTORS MFR/FMF SERIES

Feature

- Superior electrical performance
- Excellent overall stability
- Extremely low TCR down to $\pm 5\text{PPM}/^\circ\text{C}$
- Standard Value: 1R-10Meg in E96 series
- Very tight tolerance down to $\pm 0.05\%$
- Flameproof coating available (As FMF type)
- Operating Temperature : $-55^\circ\text{C} \sim +155^\circ\text{C}$

Material

Element: Vacuum-deposited Ni-Cr Alloy

Core: High purity ceramic Al_2O_3

Termination: Standard solder-plated cooper lead

Coating: Epoxy, (FMF is grey silicone)

Dimension

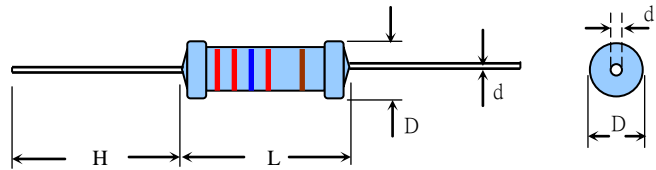

General Specification

TYPE	DIMENSION(mm)				POWER RATING	MAXIMUM WORKING VOLTAGE	MAXIMUM OVERLOAD VOLTAGE	RESISTANCE RANGE $\pm 1\%$
	L	D	H	$d \pm 0.05$				
MFR125	3.2 ± 0.2	1.6 ± 0.2	27 ± 3.0	0.45	1/8W	200V	400V	$1\ \Omega - 10\text{M}\ \Omega$
MFR025	6.0 ± 0.5	2.3 ± 0.3	27 ± 3.0	0.55	1/4W	250V	500V	$1\ \Omega - 10\text{M}\ \Omega$
MFR050	9.0 ± 0.5	3.0 ± 0.5	27 ± 3.0	0.59	1/2W	350V	700V	$1\ \Omega - 10\text{M}\ \Omega$
MFR100	11 ± 2.0	4.0 ± 1.0	33 ± 3.0	0.80	1W	500V	1000V	$1\ \Omega - 10\text{M}\ \Omega$
MFR200	15 ± 2.0	5.0 ± 1.0	33 ± 3.0	0.80	2W	500V	1000V	$1\ \Omega - 10\text{M}\ \Omega$
MFR300	17 ± 2.0	6.0 ± 1.0	33 ± 3.0	0.80	3W	500V	1000V	$1\ \Omega - 10\text{M}\ \Omega$

* Maximum Working Voltage determined by $E = \sqrt{P \cdot R}$, where E should not exceed value listed in column above.

**Maximum Overload Voltage equals to $2.5XE$, but should not exceed value listed in column above.

Derating Curve

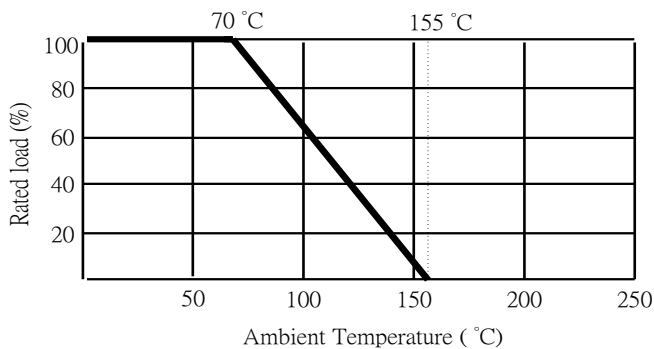

Temperature Rise

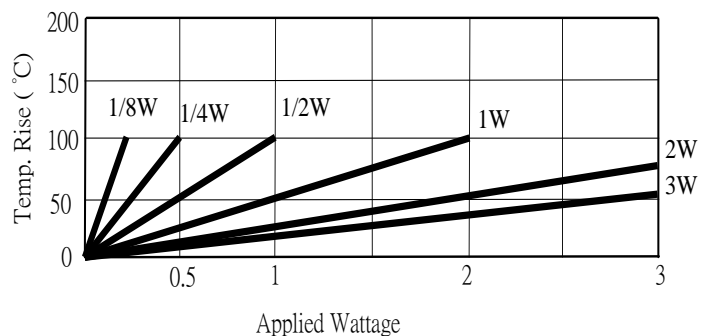

METAL FILM RESISTORS MFR/FMF SERIES

Characteristics

Item	Requirement	Test Method
Short Time Overload	±0.25%	JIS-C-5201-1 5.5 RCWV*2.5 or Max. overload voltage for 5 seconds
Insulation Resistance	> 1000MΩ	JIS-C-5201-1 5.6 Apply 100VDC for 1 minute
Endurance	±0.2%	JIS-C-5201-1 7.10 70±2°C, Max. RCWV for 1000 hrs with 1.5 hrs "ON" and 0.5hrs "OFF"
Damp Heat with Load	±0.3%	JIS-C-5201-1 7.9 40±2°C, 90~95% R.H. RCWV for 1000 hrs with 1.5 hrs "ON" and 0.5hrs "OFF"
Solderability	90% min. Coverage	JIS-C-5201-1 6.5 245±5°C for 3 seconds
Dielectric Withstanding Voltage	By Type	JIS-C-5201-1 5.7 Apply Max. Overload Voltage for 1 minute
Temperature Coefficient	50ppm 10Ω~1MΩ 100ppm <10Ω ,>1MΩ	Resistance value at room temperature and room Temperature+100°C
Pulse Overload	±0.75%	JIS-C-5201-1 5.8 4 times RCWV for 10000 cycles with 1 second "ON" and 25 seconds "OFF"
Resistance To Solvent	No deterioration of coatings and markings	JIS-C-5201-1 6.9 Trichroethane for 1 min. with ultrasonic
Terminal Strength	Tensile: ≥2.5 kg	Direct Load for 10 seconds In the direction off the terminal leads
Shelf Life	ΔR=±0.1%	12 months at room temperature 25±3°C, 80%RH Max.

Part Numbering

<u>MFR125</u>	<u>F</u>	<u>TB</u>	<u>-</u>	<u>10R</u>
↓	↓	↓	↓	↓
Type/Power	Tol.	Package	ppm	Resistance
MFR125	A=±0.05%	B=Bulk	- = Based on spec.	10R = 10Ω
MFR016				
MFR025	B=±0.1%	TB=Tape/box	E=50ppm	1K2R = 1.2KΩ
MFR050	C=±0.25%	TR=Tape/reel	D=25ppm	1MR = 1MΩ
MFR100	D=±0.5%	Lead forming	C=15ppm	
MFR200	F=±1%	M		
MFR300	J=±5%	F		

METAL FILM RESISTORS MFR/FMF SERIES

Taping/Packing Specification

Packing Methods

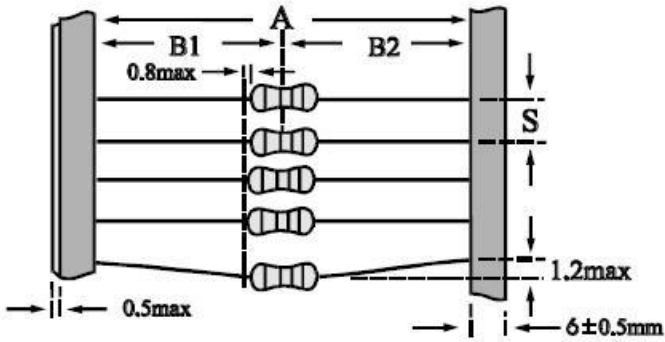

Reel Packing

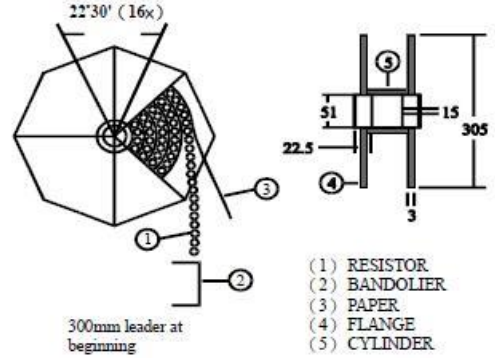

TYPE	PACKING METHOD			REEL PACKING	
	A	B1-B2	S	Across Flange (A)	Q'TY
		Max			
MFR125 MFR016	52+1/-0	1.2	5	72	5000
MFR025	52+1/-0	1.2	5	72	5000
MFR050	52+1/-0	1.2	5	72	2000
MFR100	52+1/-0	1.2	5	72	1000
	73+1/-0	1.5	5	72	1000
MFR200	52+1/-0	1.2	10	95	1000
	73+1/-0	1.5	10	95	1000
MFR300	73+1/-0	1.5	10	95	1000

Ammo Packing

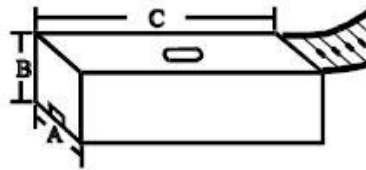

TYPE	PACKING METHOD			AMMO PACKING			
	A	B1-B2	S	A	B	C	Q'TY
		Max					
MFR125 MFR016	52+1/-0	1.2	5	80	68	255	5000
MFR025	52+1/-0	1.2	5	75	22	267	1000
		1.2	5	85	103	263	5000
MFR050	52+1/-0	1.2	5	85	95	263	2000
MFR100	52+1/-0, 73+1/-0	1.2, 1.5	5	85,103	102,85	263	1000
MFR200	52+1/-0, 73+1/-0	1.2, 1.5	10	85, 103	102,95	265	1000
MFR300	73+1/-0	1.2, 1.5	10	103	75	265	1000