

Metal Glaze Resistors

MG Series

Feature

- Superior performance against environmental condition and overload.
- Standard value: 100K-33Meg in E24 series
- Standard tolerance: $\pm 5\%$, ($\pm 1\%$ available)
- Flameproof body coating
- Identify "MG" by the fifth Orange color band
- Operating Temperature : $-55^{\circ}\text{C} \sim +155^{\circ}\text{C}$
- Color band marking, but yellow and grey color are used to substitute gold and silver because of high voltage properties in metal lacquer

Material

Element: super glaze glazed film
 Core: High purity ceramic Al_2O_3
 Termination: Standard solder-plated copper lead
 Body Coating: silicone, grey color

Dimension

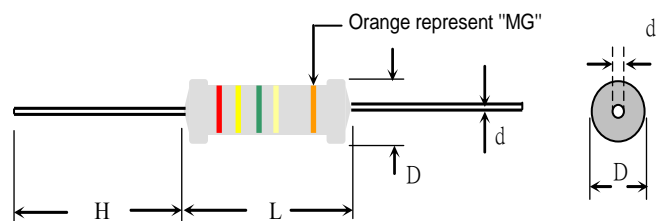

General Specification

TYPE	DIMENSION(mm)				POWER RATING	MAXIMUM WORKING VOLTAGE	MAXIMUM OVERLOAD VOLTAGE	RESISTANCE RANGE $\pm 1\%$
	L	D	H	$d \pm 0.05$				
MG025	6.0 ± 0.5	2.3 ± 0.3	27 ± 3.0	0.60	1/4W	1600V	2000V	$100\text{K}\Omega \sim 33\text{M}\Omega$
MG050	9.0 ± 0.5	3.0 ± 0.5	27 ± 3.0	0.70	1/2W	3500V	4000V	$100\text{K}\Omega \sim 33\text{M}\Omega$
MG100	11 ± 1.0	4.0 ± 0.5	33 ± 3.0	0.80	1W	4500V	5000V	$100\text{K}\Omega \sim 33\text{M}\Omega$
MG200	15 ± 1.0	5.0 ± 0.5	33 ± 3.0	0.80	2W	7000V	7500V	$100\text{K}\Omega \sim 33\text{M}\Omega$
MG300S	15 ± 1.0	5.0 ± 0.5	33 ± 3.0	0.80	3W	7000V	7500V	$100\text{K}\Omega \sim 33\text{M}\Omega$

* Maximum Working Voltage determined by $E = \sqrt{P \cdot R}$, where E should not exceed value listed in column above.

**Maximum Overload Voltage equals to 2.5XE, but should not exceed value listed in column above.

Derating Curve

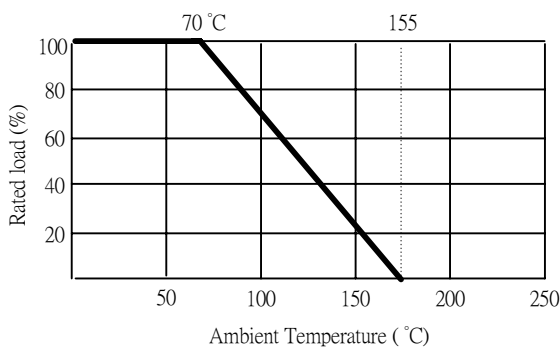

Surge Withstand Voltage

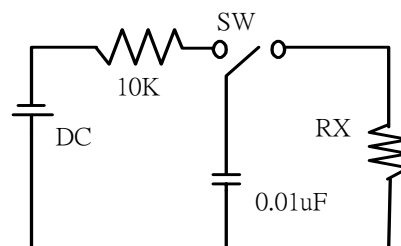

Pulse Load 10KV Max
 2.5 seconds "ON"
 2.5 seconds "OFF"
 10 cycles

Metal Glaze Resistors

MG Series

Characteristics

Item	Requirement	Test Method
Short Time Overload	±2%	JIS-C-5201-1 5.5 RCWV*2.5 or Max. overload voltage for 5 seconds
Insulation Resistance	> 1000MΩ	JIS-C-5201-1 5.6 Apply 100VDC for 1 minute
Endurance	±5%	JIS-C-5201-1 7.10 70±2°C, Max. RCWV for 1000 hrs with 1.5 hrs "ON" and 0.5hrs "OFF"
Damp Heat with Load	±5%	JIS-C-5201-1 7.9 40±2°C, 90~95% R.H. RCWV for 1000 hrs with 1.5 hrs "ON" and 0.5hrs "OFF"
Solderability	90% min. Coverage	JIS-C-5201-1 6.5 245±5°C for 3 seconds
Dielectric Withstanding Voltage	By Type	JIS-C-5201-1 5.7 Apply Max. Overload Voltage for 1 minute
Temperature Coefficient	±200ppm/°C Max.	Resistance value at room temperature and room Temperature+100°C
Pulse Overload	±20%	JIS-C-5201-1 5.8 4 times RCWV for 10000 cycles with 1 second "ON" and 25 seconds "OFF"
Terminal Strength	Tensile: ≥ 2.5 kg	Direct Load for 10 seconds In the direction off the terminal leads
Shelf Life	Δ R=±0.5%	12 months at room temperature 25±3°C, 80%RH Max.

Part Numbering

MG025 **F** **TB** - **100R**



Type/Power Tol. Package Resistance

MG025 F=±1% B=Bulk 10R = 10Ω

MG050 G=±2% TB=Tape/box 1K2R = 1.2KΩ

MG100 J=±5% TR=Tape/reel 1MR = 1MΩ

MG200

MG300S

Metal Glaze Resistors

MG Series

Taping/Packing Specification

Packing Methods

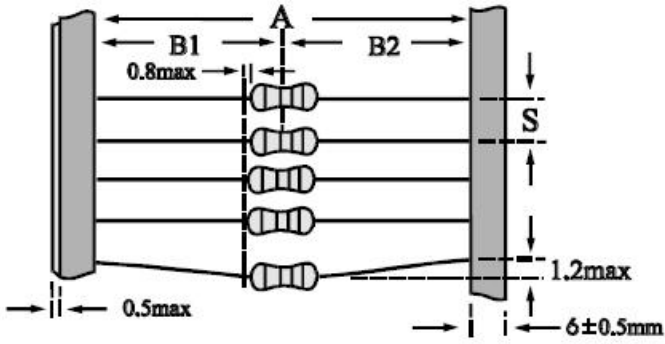

Reel Packing

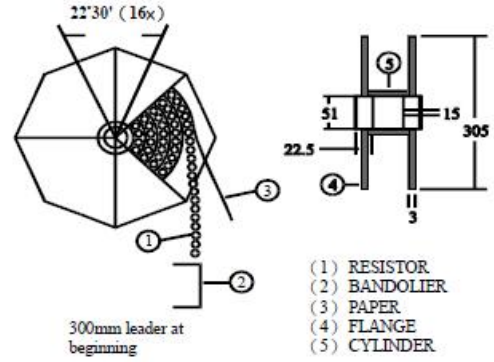

TYPE	PACKING METHOD			REEL PACKING	
	A	B1-B2	S	Across Flange (A)	Q'TY
		Max			
MG025	52+1/-0	1.2	5	72	5000
MG050	52+1/-0	1.2	5	72	2000
MG100	52+1/-0	1.2	5	72	1000
	73+1/-0	1.5	5	72	1000
MG200	52+1/-0	1.2	10	95	1000
	73+1/-0	1.5	10	95	1000

Ammo Packing

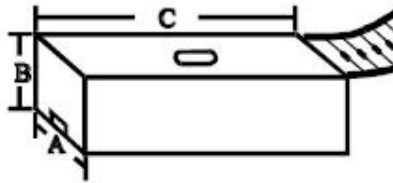

TYPE	PACKING METHOD			AMMO PACKING			
	A	B1-B2	S	A	B	C	Q'TY
		Max					
MG025	52+1/-0	1.2	5	75	22	267	1000
		1.2	5	85	103	263	5000
MG050	52+1/-0	1.2	5	85	95	263	2000
MG100	52+1/-0, 73+1/-0	1.2, 1.5	5	85,103	102,85	263	1000
MG200	52+1/-0, 73+1/-0	1.2, 1.5	10	85, 103	102,95	265	1000
MG300S	52+1/-0, 73+1/-0	1.2, 1.5	10	85, 103	102,95	265	1000