

# Resistor Networks

# SIP Series

## Feature

Thick film resistor networks have metal glaze element on the Ceramic substrate with strong clip construction terminal, and are Coated with special epoxy resin. They are most suitable to meet The requirement of high density circuit assembling.

## Dimension

(mm)

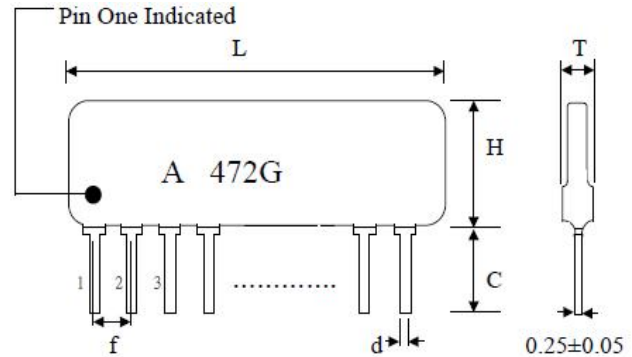

Hmax:5.08 Tmax:2.5 C:3.5±0.5 d:0.5±0.05 f:2.54±0.2

L max :

Pin	4	5	6	7	8	9	10	11	12	13	14
mm	10.2	12.7	15.3	17.8	20.4	22.9	25.4	28.0	30.5	33.1	35.6

## Circuit Diagram

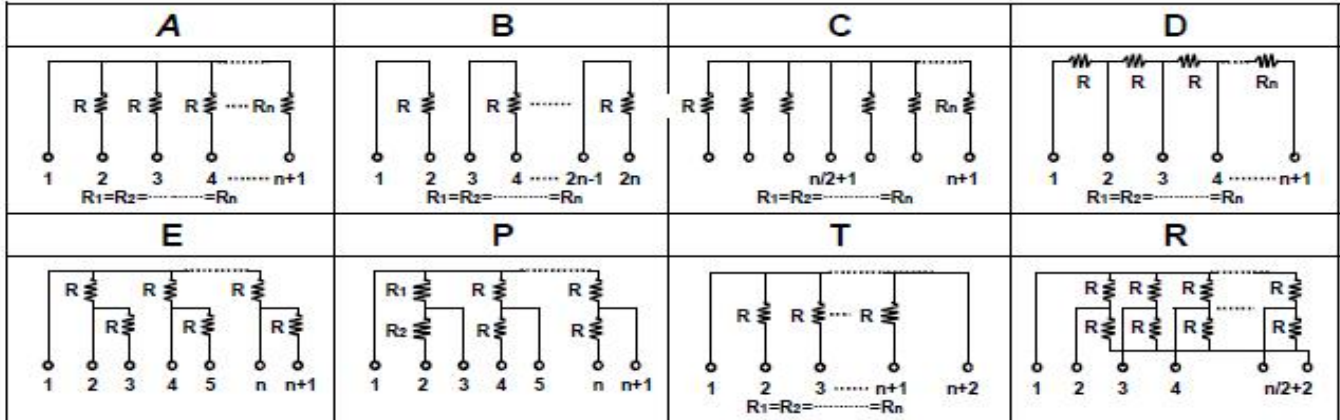

## General Specification

Rated Power	1/8W
Max. Operating Voltage	200V
Resistance tolerance	± 1%(F), ± 2%(G), ± 5%(G)
Resistance Range	10R-10Meg in E24 series
Operating Temperature Range	-55°C ~+125°C
Temperature Coefficient	R < 50 Ω, ≥ 2.2M Ω : ±250ppm/°C, 50 Ω ≥ R < 2.2M Ω : ±100ppm/°C
Rated Temperature	70°C

# Resistor Networks

# SIP Series

## Characteristics

Item	Requirement	Test Method
Short Time Overload	$\pm(2.0\%+0.1\Omega)$	JIS-C-5201-1 5.5 RCWV*2.5 or Max. overload voltage for 5 seconds
Insulation Resistance	$> 10,000M\Omega$	JIS-C-5201-1 5.6 Apply 100VDC for 1 minute
Endurance	$\pm(3\%+0.1\Omega)$	JIS-C-5201-1 7.10 70 $\pm$ 2 $^{\circ}$ C, Max. RCWV for 1000 hrs with 1.5 hrs "ON" and 0.5hrs "OFF"
Damp Heat with Load	$\pm(3\%+0.1\Omega)$	JIS-C-5201-1 7.9 40 $\pm$ 2 $^{\circ}$ C, 90~95% R.H. RCWV for 1000 hrs with 1.5 hrs "ON" and 0.5hrs "OFF"
Solderability	90% min. Coverage	JIS-C-5201-1 6.5 245 $\pm$ 5 $^{\circ}$ C for 3 seconds
Terminal Strength	$\Delta R \leq \pm(1\%+0.05\Omega)$ , No mechanical damage	Tensile: 1Kg for 30 sec. Bending: 500g for 2 times
Shelf Life	$\Delta R = \pm 0.1\%$	12 months at room temperature 25 $\pm$ 3 $^{\circ}$ C, 80%RH Max.

\*Storage Temperature : 25 $\pm$ 3 $^{\circ}$ C ; Humidity < 80%RH

## Part Numbering

<u>SIP</u>	<u>08</u>	<u>G</u>	<u>472</u>	<u>A</u>
↓	↓	↓	↓	↓
Series	Pin No.	Tol.	Resistance	Circuit Type
	08 = 8pins	F= $\pm$ 1%	Two significant	
	10=10pins	G= $\pm$ 2%	Digits followed by	
		J= $\pm$ 5%	No. of zeros	
			150 = 15 $\Omega$	
			122 = 1.2K $\Omega$	
			104 = 1M $\Omega$	

## Packing Specification

Bulk package : 4 –  $\geq$ 7pins : 200pcs/plastic bag, 25bags/box,