

Data Sheet

Customer : _____

Product : SMD Wire Wound Chip Inductor – SWI Series

Size : 0402/0603/0805/1008

Issued Date : 01-Jul.-2026

Edition : Ver. 1

Record of change

Date	Ver.	Description	Page
01-Jul.-2026	1		

HITANO ENTERPRISE CORP.

7F-7, No. 3, Wu Chuan 1st Road, New Taipei Industrial Park,
New Taipei City, TAIWAN, R.O.C.

Tel: +886 2 2299 1331 (Rep.)

Fax: +886 2 2298 2466, 2298 2969

Prepared by	Checked by	Approved by	Accepted by (customer)
01-Jul.-2026	01-Jul.-2026	01-Jul.-2026	
Randy Yu	Michelle Lin	Arthur Su	

Scope

– Ceramic body and wire wound construction provide highest SRFs available

Features

- Ceramic base provide high SRF
- Ultra-compact inductors provide high Q factors
- Low profile, high current are available
- Miniature SMD chip inductor for fully automated assembly
- Outstanding endurance from Pull-up force, mechanical shock and pressure
- Tighter tolerance down to $\pm 2\%$
- Smaller size of 0402 (1005)
- AEC-Q200 Compliance



Applications

- Smart Phone, Remote Control, Security System
- Wireless Mouse / Keyboard / Earphone
- VCO, RF Module & Other Wireless Products
- Base Station, Repeater
- GPS Receiver, WiFi, Bluetooth, Zigbee
- Antenna Matching and Filter
- CATV Filter, Tuner, Set Top Box
- IT Applications as USB 3.0 , IEEE 1394

Construction

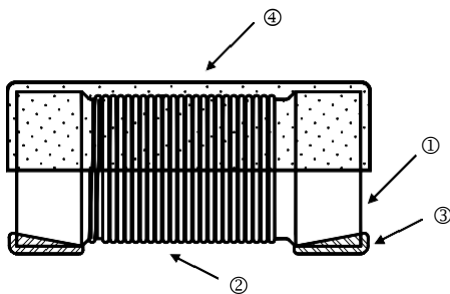

① Ceramic Core	③ Electrode
② Magnet Wire	④ UV Glue

SMD WIRE WOUND CHIP INDUCTOR

SWI SERIES

Dimensions

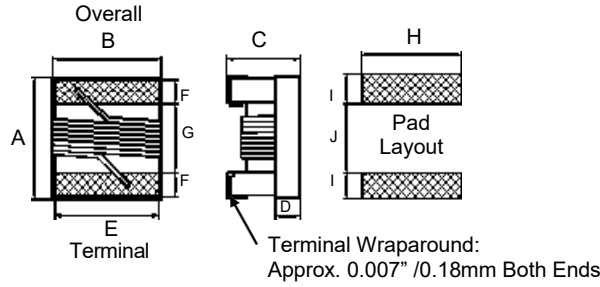

Standard

Unit : mm

Size (Inch)	A max.	B max.	C max.	D Ref.	E	F	G	H	I	J	Weight (g) (1000pcs)
0402	1.27	0.76	0.61	0.15	0.51	0.23	0.56	0.66	0.50	0.46	0.8
0603	1.80	1.12	1.02	0.38	0.76	0.33	0.86	1.02	0.64	0.64	3.46
0805	2.29	1.73	1.52	0.51	1.27	0.44	1.02	1.78	1.02	0.76	12.13
1008	2.92	2.79	2.13	0.65	2.03	0.51	1.52	2.54	1.02	1.27	30.73

High Current / High Q

Unit : mm

Size (Inch)	A max.	B max.	C max.	D Ref.	E	F	G	H	I	J
0402	1.27	0.76	0.61	0.15	0.51	0.23	0.56	0.66	0.50	0.46
0603	1.80	1.12	1.02	0.38	0.76	0.33	0.86	1.02	0.64	0.64
0805	2.29	1.73	1.52	0.51	1.27	0.44	1.02	1.78	1.02	0.76
1008	2.92	2.79	2.03	0.65	2.03	0.51	1.52	2.54	1.02	1.27

Part Numbering

SWI	0603	C	T	1N6	J	□□
SERIES	SIZE	TYPE	PACKAGE	INDUCTANCE	TOLERANCE	INTERNAL CODE
	0402	C = Standard	T= Tape&Reel	1N6= 1.6nH	C=±0.2nH	
	0603	H = High Current		82N= 82nH	D=±0.5nH	
	0805	& High Q		R27= 270nH	G= ±2%	
	1008	Q = High Q		1R0= 1000nH	J= ±5%	
		& Low DCR		103= 10000nH	K= ±10%	
					M= ±20%	

SMD WIRE WOUND CHIP INDUCTOR

SWI SERIES

Size 0402 Standard Type (□:Tolerance) :

Part No.	Inductance (nH)	Tolerance	L Freq. (MHz)	Quality Factor min.	SRF (GHz) min.	DCR (Ω) max.	IDC (mA) max.	900MHz		1.7GHz	
								L	Q	L	Q
SWI0402CT1N0□□□	1.0	±10%	250	16	12.70	0.045	1360	1.02	77	1.02	69
SWI0402CT1N3□□□	1.3	±5%,±10%	250	20	11.30	0.10	1000	0.80	35	0.80	48
SWI0402CT1N9□□□	1.9	±0.2nH,±0.5nH, ±5%,±10%	250	16	11.30	0.070	1040	1.72	68	1.74	82
SWI0402CT2N0□□□	2.0	±10%	250	16	11.10	0.070	1040	1.93	54	1.93	75
SWI0402CT2N2□□□	2.2	±5%,±10%	250	19	10.80	0.070	960	2.19	59	2.23	100
SWI0402CT2N4□□□	2.4	±5%,±10%	250	15	10.50	0.070	790	2.24	51	2.27	68
SWI0402CT2N7□□□	2.7	±5%,±10%	250	16	10.40	0.120	640	2.23	42	2.25	61
SWI0402CT3N3□□□	3.3	±5%,±10%	250	19	7.00	0.066	840	3.10	65	3.12	87
SWI0402CT3N6□□□	3.6	±2%,±5%,±10%	250	19	6.80	0.066	840	3.56	45	3.62	71
SWI0402CT3N9□□□	3.9	±5%,±10%	250	19	5.80	0.066	840	3.89	50	4.00	75
SWI0402CT4N3□□□	4.3	±5%,±10%	250	18	6.00	0.091	700	4.19	47	4.30	71
SWI0402CT4N7□□□	4.7	±5%,±10%	250	18	4.70	0.130	640	4.55	48	4.68	68
SWI0402CT5N1□□□	5.1	±2%,±5%,±10%	250	20	4.80	0.083	800	5.15	56	5.25	82
SWI0402CT5N6□□□	5.6	±2%,±5%,±10%	250	20	4.80	0.083	760	5.16	54	5.28	81
SWI0402CT6N2□□□	6.2	±2%,±5%,±10%	250	20	4.80	0.083	760	6.16	52	6.37	76
SWI0402CT6N8□□□	6.8	±2%,±5%,±10%	250	20	4.80	0.083	680	6.56	63	6.93	78
SWI0402CT7N8□□□	7.5	±2%,±5%,±10%	250	22	4.80	0.104	680	7.91	60	8.22	88
SWI0402CT8N2□□□	8.2	±2%,±5%,±10%	250	22	4.40	0.104	680	8.50	57	8.85	84
SWI0402CT8N7□□□	8.7	±5%,±10%	250	18	4.10	0.200	480	8.78	54	9.21	73
SWI0402CT9N0□□□	9.0	±2%,±5%,±10%	250	22	4.16	0.104	680	9.07	62	9.53	78
SWI0402CT9N5□□□	9.5	±5%,±10%	250	18	4.00	0.200	480	9.42	54	9.98	69
SWI0402CT10N□□□	10	±2%,±5%,±10%	250	21	3.90	0.195	480	9.80	50	10.10	67
SWI0402CT11N□□□	11	±2%,±5%,±10%	250	24	3.68	0.120	640	10.70	52	11.20	78
SWI0402CT12N□□□	12	±2%,±5%,±10%	250	24	3.60	0.120	640	11.90	53	12.70	71
SWI0402CT13N□□□	13	±2%,±5%,±10%	250	24	3.45	0.210	440	13.40	51	14.60	57
SWI0402CT15N□□□	15	±2%,±5%,±10%	250	24	3.28	0.172	560	14.60	55	15.50	77
SWI0402CT16N□□□	16	±2%,±5%,±10%	250	24	3.10	0.220	560	16.60	46	18.80	47
SWI0402CT18N□□□	18	±2%,±5%,±10%	250	25	3.10	0.230	420	18.30	57	20.30	62
SWI0402CT19N□□□	19	±2%,±5%,±10%	250	24	3.04	0.202	480	19.10	50	21.10	67
SWI0402CT20N□□□	20	±2%,±5%,±10%	250	25	3.00	0.250	420	20.70	52	23.70	53
SWI0402CT22N□□□	22	±2%,±5%,±10%	250	25	2.80	0.300	400	23.20	53	26.80	53
SWI0402CT23N□□□	23	±2%,±5%,±10%	250	24	2.72	0.300	400	23.80	49	26.90	64
SWI0402CT24N□□□	24	±2%,±5%,±10%	250	25	2.70	0.300	400	25.10	51	29.50	50
SWI0402CT27N□□□	27	±2%,±5%,±10%	250	24	2.48	0.300	400	28.70	49	33.50	63
SWI0402CT30N□□□	30	±2%,±5%,±10%	250	25	2.35	0.350	400	31.10	46	38.50	39
SWI0402CT33N□□□	33	±2%,±5%,±10%	250	24	2.35	0.350	400	34.90	31	41.70	32
SWI0402CT36N□□□	36	±2%,±5%,±10%	250	24	2.32	0.440	320	39.50	44	48.40	53
SWI0402CT39N□□□	39	±2%,±5%,±10%	250	25	2.10	0.550	200	41.70	47	50.20	45
SWI0402CT40N□□□	40	±2%,±5%,±10%	250	24	2.24	0.500	320	39.00	44	47.40	33
SWI0402CT43N□□□	43	±2%,±5%,±10%	250	25	2.03	0.810	100	45.80	46	61.60	34
SWI0402CT47N□□□	47	±2%,±5%,±10%	250	25	2.10	0.830	150	50.00	38	55.80	37
SWI0402CT51N□□□	51	±2%,±5%,±10%	250	25	1.75	0.820	100	50.40	47	59.40	37
SWI0402CT56N□□□	56	±2%,±5%,±10%	250	25	1.76	0.970	100	57.40	49	72.40	40
SWI0402CT68N□□□	68	±2%,±5%,±10%	250	22	1.62	1.120	100	69.60	45	83.40	38
SWI0402CT82N□□□	82	±2%,±5%,±10%	250	22	1.26	1.550	50	-	-	-	-
SWI0402CTR10□□□	100	±2%,±5%,±10%	250	22	1.16	2.000	30	-	-	-	-
SWI0402CTR12□□□	120	±2%,±5%,±10%	250	20	>1.80	2.660	50	-	-	-	-

SMD WIRE WOUND CHIP INDUCTOR

SWI SERIES

Size 0603 Standard Type (□:Tolerance) :

Part No.	Inductance (nH)	Tolerance	L Freq. (MHz)	Quality Factor min.	SRF (GHz) min.	DCR (Ω) max.	IDC (mA) max.	900MHz		1.7GHz	
								L	Q	L	Q
SWI0603CT1N6□□□	1.6	±5%,±10%	250	24	12.5	0.030	700	1.53	35	1.58	55
SWI0603CT1N8□□□	1.8	±2%,±5%,±10%	250	16	12.5	0.045	700	1.63	35	1.66	50
SWI0603CT2N0□□□	2.0	±0.2nH, ±0.5nH,±5%	250	16	6.90	0.080	700	1.90	31	-	-
SWI0603CT2N2□□□	2.2	±5%,±10%	250	15	6.00	0.100	700	2.18	41	2.20	64
SWI0603CT2N3□□□	2.3	±5%,±10%	250	16	>4.00	0.140	700	2.32	32	2.35	40
SWI0603CT3N3□□□	3.3	±2%,±5%,±10%	250	22	>6.00	0.080	700	3.35	47	3.40	65
SWI0603CT3N6□□□	3.6	±2%,±5%,±10%	250	22	5.80	0.063	700	3.53	49	3.58	65
SWI0603CT3N9□□□	3.9	±2%,±5%,±10%	250	22	>6.00	0.080	700	3.95	49	3.96	67
SWI0603CT4N3□□□	4.3	±2%,±5%,±10%	250	22	5.80	0.063	700	4.32	49	4.43	67
SWI0603CT4N5□□□	4.5	±2%,±5%,±10%	250	20	5.80	0.120	700	4.74	55	4.87	92
SWI0603CT4N7□□□	4.7	±2%,±5%,±10%	250	25	5.80	0.120	700	4.65	53	4.80	67
SWI0603CT5N1□□□	5.1	±2%,±5%,±10%	250	20	5.80	0.160	700	5.13	47	5.36	56
SWI0603CT5N6□□□	5.6	±2%,±5%,±10%	250	20	5.80	0.170	700	5.53	56	5.86	77
SWI0603CT6N2□□□	6.2	±2%,±5%,±10%	250	25	5.80	0.110	700	6.28	60	6.40	85
SWI0603CT6N3□□□	6.3	±2%,±5%,±10%	250	25	5.80	0.110	700	6.67	41	6.86	61
SWI0603CT6N8□□□	6.8	±2%,±5%,±10%	250	27	5.80	0.110	700	6.75	60	7.10	81
SWI0603CT7N5□□□	7.5	±2%,±5%,±10%	250	28	4.80	0.106	700	7.70	60	7.82	65
SWI0603CT8N2□□□	8.2	±2%,±5%,±10%	250	27	4.80	0.110	700	8.25	64	8.40	81
SWI0603CT8N7□□□	8.7	±2%,±5%,±10%	250	28	4.80	0.109	700	8.86	62	9.32	58
SWI0603CT9N1□□□	9.1	±2%,±5%,±10%	250	35	4.80	0.130	700	9.20	70	9.70	80
SWI0603CT9N5□□□	9.5	±2%,±5%,±10%	250	28	5.40	0.135	700	9.70	59	9.92	61
SWI0603CT10N□□□	10	±2%,±5%,±10%	250	31	4.80	0.130	700	10.0	66	10.6	83
SWI0603CT11N□□□	11	±2%,±5%,±10%	250	31	4.00	0.086	700	11.3	53	12.1	56
SWI0603CT12N□□□	12	±2%,±5%,±10%	250	35	4.00	0.130	700	12.3	72	13.5	83
SWI0603CT15N□□□	15	±2%,±5%,±10%	250	35	4.00	0.170	700	15.4	64	16.8	89
SWI0603CT16N□□□	16	±2%,±5%,±10%	250	35	3.30	0.110	700	16.5	55	18.0	52
SWI0603CT17N□□□	17	±2%,±5%,±10%	250	35	3.20	0.170	700	17.6	56	19.4	44
SWI0603CT18N□□□	18	±2%,±5%,±10%	250	35	3.10	0.170	700	18.7	70	21.4	69
SWI0603CT20N□□□	20	±2%,±5%,±10%	250	40	3.00	0.190	700	20.7	80	23.5	30
SWI0603CT22N□□□	22	±2%,±5%,±10%	250	38	3.00	0.190	700	22.8	73	26.1	71
SWI0603CT23N□□□	23	±2%,±5%,±10%	250	38	2.85	0.190	700	24.1	71	28.0	71
SWI0603CT24N□□□	24	±2%,±5%,±10%	250	38	2.80	0.130	700	25.7	45	30.9	40
SWI0603CT27N□□□	27	±2%,±5%,±10%	250	40	2.80	0.220	600	29.2	74	34.6	65
SWI0603CT30N□□□	30	±2%,±5%,±10%	250	40	2.80	0.150	600	31.4	47	39.8	28
SWI0603CT33N□□□	33	±2%,±5%,±10%	250	40	2.30	0.220	600	36.0	67	49.5	42
SWI0603CT36N□□□	36	±2%,±5%,±10%	250	37	2.30	0.250	600	39.1	47	48.9	24
SWI0603CT39N□□□	39	±2%,±5%,±10%	250	40	2.20	0.250	600	42.7	60	60.2	40
SWI0603CT43N□□□	43	±2%,±5%,±10%	200	38	2.00	0.280	600	46.9	44	60.3	21
SWI0603CT47N□□□	47	±2%,±5%,±10%	200	38	2.00	0.280	600	52.2	62	77.2	35
SWI0603CT51N□□□	51	±2%,±5%,±10%	200	38	1.90	0.280	600	55.5	69	82.2	34
SWI0603CT56N□□□	56	±2%,±5%,±10%	200	38	1.90	0.310	600	62.5	56	97.0	26
SWI0603CT62N□□□	62	±2%,±5%,±10%	200	37	1.80	0.340	600	68.0	40	110	10
SWI0603CT68N□□□	68	±2%,±5%,±10%	200	37	1.70	0.340	600	80.5	54	168	21
SWI0603CT72N□□□	72	±2%,±5%,±10%	150	34	1.70	0.490	600	82.0	53	135	20
SWI0603CT82N□□□	82	±2%,±5%,±10%	150	34	1.70	0.540	400	96.2	54	177	21
SWI0603CT92N□□□	91	±2%,±5%,±10%	150	30	1.70	0.500	400	110.0	50	416.4	6
SWI0603CTR10□□□	100	±2%,±5%,±10%	150	34	1.40	0.580	400	124.0	49	319.5	13
SWI0603CTR11□□□	110	±2%,±5%,±10%	150	32	1.35	0.610	300	138.0	43	342.7	15
SWI0603CTR12□□□	120	±2%,±5%,±10%	150	32	1.30	0.650	300	166.0	39	529.3	8
SWI0603CTR13□□□	130	±2%,±5%,±10%	150	30	1.40	0.720	300	185.0	60	-	-
SWI0603CTR14□□□	140	±2%,±5%,±10%	100	28	1.30	0.870	280	190.0	80	-	-
SWI0603CTR15□□□	150	±2%,±5%,±10%	100	28	1.30	0.950	280	230.0	25	-	-
SWI0603CTR16□□□	160	±2%,±5%,±10%	100	25	1.30	1.400	280	215.0	20	-	-
SWI0603CTR18□□□	180	±2%,±5%,±10%	100	25	1.25	1.400	250	305.0	22	-	-
SWI0603CTR20□□□	200	±2%,±5%,±10%	100	25	-	1.400	250	-	-	-	-
SWI0603CTR22□□□	220	±2%,±5%,±10%	100	25	1.20	1.600	250	377.0	21	-	-
SWI0603CTR24□□□	240	±2%,±5%,±10%	100	25	1.20	2.000	250	377.0	21	-	-
SWI0603CTR25□□□	250	±2%,±5%,±10%	100	25	1.20	2.000	250	377.0	21	-	-
SWI0603CTR26□□□	260	±2%,±5%,±10%	100	25	1.00	2.000	200	469.0	21	-	-
SWI0603CTR27□□□	270	±2%,±5%,±10%	100	25	0.90	2.100	200	523.0	19	-	-
SWI0603CTR28□□□	280	±2%,±5%,±10%	100	25	1.00	2.400	100	524.0	18	-	-
SWI0603CTR30□□□	300	±2%,±5%,±10%	100	25	0.75	2.500	150	539.7	21	-	-
SWI0603CTR33□□□	330	±2%,±5%,±10%	100	25	0.90	3.800	100	680.4	20	-	-
SWI0603CTR39□□□	390	±2%,±5%,±10%	100	25	0.90	4.350	100	734.5	29	-	-
SWI0603CTR47□□□	470	±2%,±5%,±10%	100	23	0.60	3.600	80	-	-	-	-

SMD WIRE WOUND CHIP INDUCTOR

SWI SERIES

Size 0805 Standard Type (□:Tolerance) :

Part No.	Inductance (nH)	Tolerance	L Freq. (MHz)	Quality Factor min.	SRF (GHz) min.	DCR (Ω) max.	IDC (mA) max.
SWI0805CT2N7□□□	2.7	±5%,±10%	250	80 @ 1500MHz	7.900	0.06	800
SWI0805CT2N8□□□	2.8	±2%,±5%,±10%	250	80 @ 1500MHz	7.900	0.06	800
SWI0805CT3N3□□□	3.0	±5%,±10%	250	65 @ 1500MHz	7.900	0.06	800
SWI0805CT3N3□□□	3.3	±5%,±10%	250	50 @ 1500MHz	6.000	0.08	600
SWI0805CT3N9□□□	3.9	±5%,±10%	250	50 @ 1500MHz	5.500	0.08	600
SWI0805CT4N7□□□	4.7	±5%,±10%	250	65 @ 1000MHz	5.500	0.08	600
SWI0805CT5N6□□□	5.6	±5%,±10%	250	65 @ 1000MHz	5.500	0.08	600
SWI0805CT6N2□□□	6.2	±5%,±10%	250	50 @ 1000MHz	5.500	0.11	600
SWI0805CT6N8□□□	6.8	±5%,±10%	250	50 @ 1000MHz	5.500	0.11	600
SWI0805CT7N5□□□	7.5	±5%,±10%	250	50 @ 1000MHz	4.500	0.14	600
SWI0805CT8N2□□□	8.2	±5%,±10%	250	50 @ 1000MHz	4.700	0.12	600
SWI0805CT8N7□□□	8.7	±5%,±10%	250	50 @ 1000MHz	4.000	0.21	400
SWI0805CT10N□□□	10	±2%,±5%,±10%	250	60 @ 500MHz	4.200	0.10	600
SWI0805CT12N□□□	12	±2%,±5%,±10%	250	50 @ 500MHz	4.000	0.15	600
SWI0805CT15N□□□	15	±2%,±5%,±10%	250	50 @ 500MHz	3.400	0.17	600
SWI0805CT18N□□□	18	±2%,±5%,±10%	250	50 @ 500MHz	3.300	0.20	600
SWI0805CT20N□□□	20	±2%,±5%,±10%	250	55 @ 500MHz	2.600	0.22	500
SWI0805CT22N□□□	22	±2%,±5%,±10%	250	55 @ 500MHz	2.600	0.22	500
SWI0805CT24N□□□	24	±2%,±5%,±10%	250	50 @ 500MHz	2.000	0.22	500
SWI0805CT27N□□□	27	±2%,±5%,±10%	250	55 @ 500MHz	2.500	0.25	500
SWI0805CT30N□□□	30	±2%,±5%,±10%	250	60 @ 500MHz	2.050	0.25	500
SWI0805CT33N□□□	33	±2%,±5%,±10%	250	60 @ 500MHz	2.050	0.27	500
SWI0805CT36N□□□	36	±2%,±5%,±10%	250	55 @ 500MHz	1.700	0.27	500
SWI0805CT39N□□□	39	±2%,±5%,±10%	250	60 @ 500MHz	2.000	0.29	500
SWI0805CT43N□□□	43	±2%,±5%,±10%	200	60 @ 500MHz	1.650	0.34	500
SWI0805CT47N□□□	47	±2%,±5%,±10%	200	60 @ 500MHz	1.650	0.31	500
SWI0805CT51N□□□	51	±2%,±5%,±10%	200	60 @ 500MHz	1.650	0.34	500
SWI0805CT56N□□□	56	±2%,±5%,±10%	200	60 @ 500MHz	1.550	0.34	500
SWI0805CT62N□□□	62	±2%,±5%,±10%	200	60 @ 500MHz	1.500	0.36	500
SWI0805CT68N□□□	68	±2%,±5%,±10%	200	60 @ 500MHz	1.450	0.38	500
SWI0805CT72N□□□	72	±2%,±5%,±10%	150	65 @ 500MHz	1.400	0.40	500
SWI0805CT75N□□□	75	±2%,±5%,±10%	150	65 @ 500MHz	1.350	0.41	500
SWI0805CT82N□□□	82	±2%,±5%,±10%	150	65 @ 500MHz	1.300	0.42	400
SWI0805CT91N□□□	91	±2%,±5%,±10%	150	65 @ 500MHz	1.200	0.48	400
SWI0805CTR10□□□	100	±2%,±5%,±10%	150	65 @ 500MHz	1.200	0.46	400
SWI0805CTR11□□□	110	±2%,±5%,±10%	150	50 @ 250MHz	1.000	0.48	400
SWI0805CTR12□□□	120	±2%,±5%,±10%	150	50 @ 250MHz	1.100	0.51	400
SWI0805CTR13□□□	130	±2%,±5%,±10%	150	50 @ 250MHz	0.980	0.54	400
SWI0805CTR15□□□	150	±2%,±5%,±10%	100	50 @ 250MHz	0.920	0.56	400
SWI0805CTR16□□□	160	±2%,±5%,±10%	100	50 @ 250MHz	0.870	0.60	400
SWI0805CTR18□□□	180	±2%,±5%,±10%	100	50 @ 250MHz	0.870	0.64	400
SWI0805CTR20□□□	200	±2%,±5%,±10%	100	50 @ 250MHz	0.860	0.66	400
SWI0805CTR22□□□	220	±2%,±5%,±10%	100	50 @ 250MHz	0.850	0.70	400
SWI0805CTR24□□□	240	±2%,±5%,±10%	100	44 @ 250MHz	0.690	1.00	350
SWI0805CTR25□□□	250	±2%,±5%,±10%	100	50 @ 250MHz	0.680	1.00	350
SWI0805CTR27□□□	270	±2%,±5%,±10%	100	48 @ 250MHz	0.650	1.00	350
SWI0805CTR30□□□	300	±2%,±5%,±10%	100	48 @ 250MHz	0.620	1.20	330
SWI0805CTR33□□□	330	±2%,±5%,±10%	100	48 @ 250MHz	0.600	1.40	310
SWI0805CTR36□□□	360	±2%,±5%,±10%	100	48 @ 250MHz	0.580	1.45	300
SWI0805CTR39□□□	390	±2%,±5%,±10%	100	48 @ 250MHz	0.560	1.50	290
SWI0805CTR43□□□	430	±2%,±5%,±10%	50	33 @ 100MHz	0.430	1.70	230
SWI0805CTR47□□□	470	±2%,±5%,±10%	50	33 @ 100MHz	0.375	1.70	250
SWI0805CTR51□□□	510	±2%,±5%,±10%	25	23 @ 50MHz	0.365	1.90	240
SWI0805CTR56□□□	560	±2%,±5%,±10%	25	23 @ 50MHz	0.340	1.90	230
SWI0805CTR60□□□	600	±2%,±5%,±10%	25	23 @ 50MHz	0.260	1.60	450
SWI0805CTR62□□□	620	±2%,±5%,±10%	25	23 @ 50MHz	0.220	2.20	210
SWI0805CTR68□□□	680	±2%,±5%,±10%	25	23 @ 50MHz	0.200	2.20	190
SWI0805CTR75□□□	750	±2%,±5%,±10%	25	23 @ 50MHz	0.200	2.30	180
SWI0805CTR82□□□	820	±2%,±5%,±10%	25	23 @ 50MHz	0.200	2.35	180

SMD WIRE WOUND CHIP INDUCTOR

SWI SERIES

Size 0805 Standard Type (□:Tolerance) :

Part No.	Inductance (nH)	Tolerance	L Freq. (MHz)	Quality Factor min.	SRF (GHz) min.	DCR (Ω) max.	IDC (mA) max.
SWI0805CT1R0□□□	1000	±2%,±5%,±10%	25	20 @ 50MHz	0.100	2.50	170
SWI0805CT1R2□□□	1200	±2%,±5%,±10%	7.9	18 @ 25MHz	0.100	2.50	170
SWI0805CT1R5□□□	1500	±2%,±5%,±10%	7.9	16 @ 25MHz	0.100	2.50	170
SWI0805CT1R8□□□	1800	±2%,±5%,±10%	7.9	16 @ 7.9MHz	0.080	2.50	170
SWI0805CT2R2□□□	2200	±2%,±5%,±10%	7.9	16 @ 7.9MHz	0.060	2.70	160
SWI0805CT2R7□□□	2700	±2%,±5%,±10%	7.9	16 @ 7.9MHz	0.050	3.10	150
SWI0805CT3R3□□□	3300	±2%,±5%,±10%	7.9	15 @ 7.9MHz	0.040	4.40	90
SWI0805CT3R9□□□	3900	±2%,±5%,±10%	7.9	15 @ 7.9MHz	0.040	4.41	90
SWI0805CT4R7□□□	4700	±2%,±5%,±10%	7.9	15 @ 7.9MHz	0.040	6.40	90
SWI0805CT5R6□□□	5600	±2%,±5%,±10%	7.9	20 @ 10MHz	0.075	7.00	100
SWI0805CT6R8□□□	6800	±2%,±5%,±10%	7.9	20 @ 10MHz	0.065	9.80	80

Size 1008 Standard Type (□:Tolerance) :

Part No.	Inductance (nH)	Tolerance	L Freq. (MHz)	Quality Factor min.	SRF (GHz) min.	DCR (Ω) max.	IDC (mA) max.
SWI1008CT4N2□□□	4.2	±5%,±10%	50	50 @ 500MHz	4.000	0.15	1000
SWI1008CT4N7□□□	4.7	±5%,±10%	50	50 @ 500MHz	4.000	0.15	1000
SWI1008CT5N6□□□	5.6	±5%,±10%	50	50 @ 500MHz	4.000	0.15	1000
SWI1008CT8N2□□□	8.2	±5%,±10%	50	50 @ 500MHz	4.100	0.08	1000
SWI1008CT10N□□□	10	±2%,±5%,±10%	50	50 @ 500MHz	4.100	0.08	1000
SWI1008CT12N□□□	12	±2%,±5%,±10%	50	50 @ 500MHz	3.300	0.09	1000
SWI1008CT15N□□□	15	±2%,±5%,±10%	50	50 @ 500MHz	2.500	0.11	1000
SWI1008CT18N□□□	18	±2%,±5%,±10%	50	50 @ 350MHz	2.400	0.12	1000
SWI1008CT22N□□□	22	±2%,±5%,±10%	50	55 @ 350MHz	2.400	0.12	1000
SWI1008CT24N□□□	24	±2%,±5%,±10%	50	55 @ 350MHz	1.900	0.13	1000
SWI1008CT27N□□□	27	±2%,±5%,±10%	50	55 @ 350MHz	1.600	0.13	1000
SWI1008CT30N□□□	30	±2%,±5%,±10%	50	60 @ 350MHz	1.600	0.14	1000
SWI1008CT33N□□□	33	±2%,±5%,±10%	50	60 @ 350MHz	1.600	0.14	1000
SWI1008CT36N□□□	36	±2%,±5%,±10%	50	60 @ 350MHz	1.6000	0.15	1000
SWI1008CT39N□□□	39	±2%,±5%,±10%	50	60 @ 350MHz	1.500	0.15	1000
SWI1008CT43N□□□	43	±2%,±5%,±10%	50	60 @ 350MHz	1.500	0.16	1000
SWI1008CT47N□□□	47	±2%,±5%,±10%	50	65 @ 350MHz	1.500	0.16	1000
SWI1008CT56N□□□	56	±2%,±5%,±10%	50	65 @ 350MHz	1.300	0.18	1000
SWI1008CT62N□□□	62	±2%,±5%,±10%	50	65 @ 350MHz	1.250	0.20	1000
SWI1008CT68N□□□	68	±2%,±5%,±10%	50	65 @ 350MHz	1.300	0.20	1000
SWI1008CT75N□□□	75	±2%,±5%,±10%	50	60 @ 350MHz	1.100	0.21	1000
SWI1008CT82N□□□	82	±2%,±5%,±10%	50	60 @ 350MHz	1.000	0.22	1000
SWI1008CT91N□□□	91	±2%,±5%,±10%	50	50 @ 350MHz	1.000	0.45	1000
SWI1008CTR10□□□	100	±2%,±5%,±10%	25	60 @ 350MHz	1.000	0.56	650
SWI1008CTR12□□□	120	±2%,±5%,±10%	25	60 @ 350MHz	0.950	0.63	650
SWI1008CTR15□□□	150	±2%,±5%,±10%	25	45 @ 100MHz	0.850	0.70	800
SWI1008CTR18□□□	180	±2%,±5%,±10%	25	45 @ 100MHz	0.750	0.77	620
SWI1008CTR22□□□	220	±2%,±5%,±10%	25	45 @ 100MHz	0.700	0.84	500
SWI1008CTR24□□□	240	±2%,±5%,±10%	25	45 @ 100MHz	0.650	0.88	500
SWI1008CTR27□□□	270	±2%,±5%,±10%	25	45 @ 100MHz	0.600	0.91	690
SWI1008CTR30□□□	300	±2%,±5%,±10%	25	45 @ 100MHz	0.585	1.00	450
SWI1008CTR33□□□	330	±2%,±5%,±10%	25	45 @ 100MHz	0.570	1.05	450
SWI1008CTR36□□□	360	±2%,±5%,±10%	25	45 @ 100MHz	0.530	1.10	470
SWI1008CTR39□□□	390	±2%,±5%,±10%	25	45 @ 100MHz	0.500	1.12	630
SWI1008CTR43□□□	430	±2%,±5%,±10%	25	45 @ 100MHz	0.480	1.15	470
SWI1008CTR47□□□	470	±2%,±5%,±10%	25	45 @ 100MHz	0.450	1.19	470

SMD WIRE WOUND CHIP INDUCTOR

SWI SERIES

Size 1008 Standard Type (□:Tolerance) :

Part No.	Inductance (nH)	Tolerance	L Freq. (MHz)	Quality Factor min.	SRF (GHz) min.	DCR (Ω) max.	IDC (mA) max.
SWI1008CTR56□□□	560	±2%,±5%,±10%	25	45 @ 100MHz	0.415	1.33	580
SWI1008CTR62□□□	620	±2%,±5%,±10%	25	45 @ 100MHz	0.375	1.40	300
SWI1008CTR68□□□	680	±2%,±5%,±10%	25	45 @ 100MHz	0.375	1.47	540
SWI1008CTR75□□□	750	±2%,±5%,±10%	25	45 @ 100MHz	0.360	1.54	360
SWI1008CTR82□□□	820	±2%,±5%,±10%	25	45 @ 100MHz	0.350	1.61	400
SWI1008CTR91□□□	910	±2%,±5%,±10%	25	35 @ 50MHz	0.320	1.68	380
SWI1008CT1R0□□□	1000	±2%,±5%,±10%	25	35 @ 50MHz	0.290	1.75	370
SWI1008CT1R2□□□	1200	±2%,±5%,±10%	7.9	35 @ 50MHz	0.250	2.00	310
SWI1008CT1R8□□□	1800	±2%,±5%,±10%	7.9	28 @ 50MHz	0.160	2.60	300
SWI1008CT2R2□□□	2200	±2%,±5%,±10%	7.9	28 @ 50MHz	0.160	2.80	280
SWI1008CT2R7□□□	2700	±2%,±5%,±10%	7.9	22 @25MHz	0.140	3.20	290
SWI1008CT3R3□□□	3300	±2%,±5%,±10%	7.9	22 @25MHz	0.110	3.40	290
SWI1008CT3R9□□□	3900	±2%,±5%,±10%	7.9	18 @ 25MHz	0.100	3.60	260
SWI1008CT4R7□□□	4700	±2%,±5%,±10%	7.9	18 @ 25MHz	0.090	4.00	260
SWI1008CT5R6□□□	5600	±2%,±5%,±10%	7.9	16@ 7.96MHz	0.020	4.00	260
SWI1008CT6R8□□□	6800	±2%,±5%,±10%	7.9	15 @ 7.96MHz	0.040	4.90	200
SWI1008CT8R2□□□	8200	±2%,±5%,±10%	7.9	15 @ 7.96MHz	0.025	6.00	170
SWI1008CT103□□□	10000	±2%,±5%,±10%	2.52	15 @ 7.96MHz	0.020	9.00	150
SWI1008CT123□□□	12000	±2%,±5%,±10%	2.52	15 @ 7.96MHz	0.018	10.50	130
SWI1008CT153□□□	15000	±2%,±5%,±10%	2.52	15 @ 7.96MHz	0.015	11.50	120

WIRE WOUND CHIP INDUCTOR

SWI SERIES

Size 0402 High Current & High Q Type (□:Tolerance) :

Part No.	Inductance (nH)	Tolerance	L Freq. (MHz)	Quality Factor		SRF (GHz) min.	DCR (Ω) max.	IDC (mA) max.
				900MHz	1.7GHz			
SWI0402HT1N0□□□	1.0	±0.2nH,±0.5nH,±5%,±10%	250	46	75	16.0	0.030	2300
SWI0402HT2N0□□□	2.0	±0.2nH,±0.5nH,±5%,±10%	250	58	85	15.2	0.038	2100
SWI0402HT2N2□□□	2.2	±0.2nH,±0.5nH,±5%,±10%	250	60	86	15.1	0.038	2100
SWI0402HT2N4□□□	2.4	±0.2nH,±0.5nH,±5%,±10%	250	60	83	14.0	0.042	2000
SWI0402HT2N7□□□	2.7	±0.2nH,±0.5nH,±5%,±10%	250	62	85	13.0	0.075	1500
SWI0402HT3N3□□□	3.3	±0.2nH,±0.5nH,±5%,±10%	250	66	95	12.8	0.045	1700
SWI0402HT3N6□□□	3.6	±0.2nH,±0.5nH,±5%,±10%	250	65	94	11.7	0.045	1700
SWI0402HT3N9□□□	3.9	±0.2nH,±0.5nH,±5%,±10%	250	64	98	9.50	0.045	1700
SWI0402HT4N3□□□	4.3	±0.5nH,±5%,±10%	250	63	90	7.15	0.050	1600
SWI0402HT4N7□□□	4.7	±0.5nH,±5%,±10%	250	58	83	6.85	0.070	1500
SWI0402HT5N1□□□	5.1	±2%,±5%,±10%	250	54	76	6.80	0.115	1200
SWI0402HT5N6□□□	5.6	±2%,±5%,±10%	250	73	105	6.50	0.050	1600
SWI0402HT6N2□□□	6.2	±2%,±5%,±10%	250	73	100	5.80	0.055	1600
SWI0402HT6N8□□□	6.8	±2%,±5%,±10%	250	68	94	5.80	0.065	1500
SWI0402HT7N5□□□	7.5	±2%,±5%,±10%	250	60	82	5.40	0.090	1400
SWI0402HT8N2□□□	8.2	±2%,±5%,±10%	250	68	95	5.40	0.065	1500
SWI0402HT8N7□□□	8.7	±2%,±5%,±10%	250	68	95	5.00	0.065	1500
SWI0402HT9N0□□□	9.0	±2%,±5%,±10%	250	67	92	5.00	0.080	1400
SWI0402HT9N5□□□	9.5	±2%,±5%,±10%	250	64	90	4.70	0.090	1400
SWI0402HT10N□□□	10	±2%,±5%,±10%	250	62	90	4.70	0.100	1300
SWI0402HT11N□□□	11	±2%,±5%,±10%	250	68	98	4.70	0.065	1400
SWI0402HT12N□□□	12	±2%,±5%,±10%	250	66	100	4.40	0.100	1200
SWI0402HT13N□□□	13	±2%,±5%,±10%	250	62	82	4.20	0.150	870
SWI0402HT15N□□□	15	±2%,±5%,±10%	250	62	85	3.90	0.110	1100
SWI0402HT16N□□□	16	±2%,±5%,±10%	250	57	77	3.70	0.140	850
SWI0402HT18N□□□	18	±2%,±5%,±10%	250	58	74	3.55	0.120	900
SWI0402HT19N□□□	19	±2%,±5%,±10%	250	61	88	3.50	0.145	850
SWI0402HT20N□□□	20	±2%,±5%,±10%	250	58	76	3.50	0.185	780
SWI0402HT21N□□□	21	±2%,±5%,±10%	250	48	62	1.70	0.460	450
SWI0402HT22N□□□	22	±2%,±5%,±10%	250	60	74	3.30	0.160	800
SWI0402HT23N□□□	23	±2%,±5%,±10%	250	60	77	3.30	0.160	800
SWI0402HT24N□□□	24	±2%,±5%,±10%	250	55	71	3.15	0.200	700
SWI0402HT25N□□□	25	±2%,±5%,±10%	250	57	73	3.15	0.250	600
SWI0402HT26N□□□	26	±2%,±5%,±10%	250	56	74	3.15	0.285	450
SWI0402HT27N□□□	27	±2%,±5%,±10%	250	62	86	3.20	0.320	450
SWI0402HT30N□□□	30	±2%,±5%,±10%	250	61	87	2.90	0.330	450
SWI0402HT33N□□□	33	±2%,±5%,±10%	250	61	80	2.80	0.330	490
SWI0402HT36N□□□	36	±2%,±5%,±10%	250	59	76	2.80	0.380	480
SWI0402HT37N□□□	37	±2%,±5%,±10%	250	57	72	2.70	0.460	470
SWI0402HT39N□□□	39	±2%,±5%,±10%	250	56	84	2.60	0.430	450
SWI0402HT40N□□□	40	±2%,±5%,±10%	250	56	75	2.60	0.430	450
SWI0402HT43N□□□	43	±2%,±5%,±10%	250	52	68	2.50	0.520	450
SWI0402HT47N□□□	47	±2%,±5%,±10%	250	48	62	2.40	0.580	420
SWI0402HT51N□□□	51	±2%,±5%,±10%	250	52	59	2.30	0.700	360
SWI0402HT56N□□□	56	±2%,±5%,±10%	250	45	30	2.30	0.700	360
SWI0402HT82N□□□	82	±5%,±10%	250	37	-	1.75	1.100	315
SWI0402HTR10□□□	100	±2%,±5%,±10%	250	50	-	1.50	1.400	315
SWI0402HTR15□□□	150	±5%,±10%	100	-	-	1.14	2.300	240

WIRE WOUND CHIP INDUCTOR

SWI SERIES

Size 0603 High Current & High Q Type (□:Tolerance) :

Part No.	Inductance (nH)	Tolerance	L Freq. (MHz)	Quality Factor min.	SRF (GHz) min.	DCR (Ω) max.	IDC (mA) max.
SWI0603HT1N6□□□	1.6	±5%,±10%	250	24	12.50	0.030	2400
SWI0603HT3N6□□□	3.6	±5%,±10%	250	24	5.90	0.048	2300
SWI0603HT3N9□□□	3.9	±5%,±10%	250	25	5.90	0.054	2200
SWI0603HT6N8□□□	6.8	±5%,±10%	250	35	5.80	0.054	2100
SWI0603HT7N5□□□	7.5	±5%,±10%	250	38	3.70	0.059	2100
SWI0603HT8N2□□□	8.2	±5%,±10%	250	38	3.70	0.060	2000
SWI0603HT10N□□□	10	±2%,±5%,±10%	250	38	3.70	0.071	2000
SWI0603HT12N□□□	12	±2%,±5%,±10%	250	38	3.00	0.075	2000
SWI0603HT15N□□□	15	±2%,±5%,±10%	250	38	2.80	0.080	1900
SWI0603HT18N□□□	18	±2%,±5%,±10%	250	40	2.80	0.099	1900
SWI0603HT22N□□□	22	±2%,±5%,±10%	250	42	2.40	0.099	1800
SWI0603HT22N□□□	24	±2%,±5%,±10%	250	42	2.40	0.105	1800

Size 0805 High Current & High Q Type (□:Tolerance) :

Part No.	Inductance (nH)	Tolerance	L Freq. (MHz)	Quality Factor min.	SRF (GHz) min.	DCR (Ω) max.	IDC (mA) max.
SWI0805HT2N5□□□	2.5	±5%,±10%	250	80 @ 1500MHz	6.00	0.020	1600
SWI0805HT5N6□□□	5.6	±5%,±10%	250	98 @ 1500MHz	6.00	0.035	1600
SWI0805HT6N2□□□	6.2	±5%,±10%	250	88 @ 1000MHz	4.75	0.035	1600
SWI0805HT6N8□□□	6.8	±5%,±10%	250	80 @ 1000MHz	4.40	0.035	1600
SWI0805HT8N2□□□	8.2	±5%,±10%	250	75 @ 1000MHz	3.00	0.075	1000
SWI0805HT10N□□□	10	±5%,±10%	250	80 @ 1000MHz	3.00	0.060	1600
SWI0805HT12N□□□	12	±5%,±10%	250	80 @ 1000MHz	3.00	0.045	1600
SWI0805HT15N□□□	15	±2%,±5%,±10%	250	80 @ 1000MHz	2.80	0.100	1200
SWI0805HT16N□□□	16	±2%,±5%,±10%	250	72 @ 500MHz	2.95	0.060	1500
SWI0805HT18N□□□	18	±2%,±5%,±10%	250	75 @ 500MHz	2.55	0.060	1400
SWI0805HT20N□□□	20	±2%,±5%,±10%	250	70 @ 500MHz	2.05	0.055	1400
SWI0805HT22N□□□	22	±2%,±5%,±10%	250	80 @ 500MHz	2.00	0.100	1200
SWI0805HT27N□□□	27	±2%,±5%,±10%	250	75 @ 500MHz	2.00	0.070	1300
SWI0805HT30N□□□	30	±2%,±5%,±10%	250	65 @ 500MHz	1.95	0.095	1200
SWI0805HT39N□□□	39	±2%,±5%,±10%	250	65 @ 500MHz	1.60	0.110	1100
SWI0805HT41N□□□	48	±2%,±5%,±10%	200	65 @ 500MHz	1.40	0.095	1200
SWI0805HT51N□□□	51	±2%,±5%,±10%	200	65 @ 500MHz	1.40	0.120	1000
SWI0805HTR10□□□	100	±2%,±5%,±10%	150	90 @ 500MHz	1.00	0.220	600
SWI0805HTR12□□□	120	±2%,±5%,±10%	150	60 @ 250MHz	1.00	0.293	600
SWI0805HTR15□□□	150	±2%,±5%,±10%	100	65 @ 250MHz	1.00	0.288	600

WIRE WOUND CHIP INDUCTOR

SWI SERIES

Size 1008 High Current & High Q Type (□:Tolerance) :

Part No.	Inductance (nH)	Tolerance	L Freq. (MHz)	Quality Factor min.	SRF (GHz) min.	DCR (Ω) max.	IDC (mA) max.
SWI1008HT3N0□□□	3.0	±5, ±10%	50	70 @ 1500MHz	6.00	0.04	1600
SWI1008HT3N9□□□	3.9	±5, ±10%	50	75 @ 1500MHz	6.00	0.05	1600
SWI1008HT4N1□□□	4.1	±5, ±10%	50	75 @ 1500MHz	6.00	0.05	1600
SWI1008HT7N8□□□	7.8	±5, ±10%	50	75 @ 500MHz	3.80	0.05	1600
SWI1008HT10N□□□	10	±2, ±5, ±10%	50	60 @ 500MHz	3.60	0.06	1600
SWI1008HT12N□□□	12	±2, ±5, ±10%	50	70 @ 500MHz	2.80	0.06	1500
SWI1008HT18N□□□	18	±2, ±5, ±10%	50	62 @ 350MHz	2.70	0.07	1400
SWI1008HT22N□□□	22	±2, ±5, ±10%	50	62 @ 350MHz	2.05	0.07	1400
SWI1008HT33N□□□	33	±2, ±5, ±10%	50	75 @ 350MHz	1.70	0.09	1300
SWI1008HT39N□□□	39	±2, ±5, ±10%	50	75 @ 350MHz	1.30	0.09	1300
SWI1008HT47N□□□	47	±2, ±5, ±10%	50	75 @ 350MHz	1.45	0.12	1200
SWI1008HT56N□□□	56	±2, ±5, ±10%	50	75 @ 350MHz	1.23	0.12	1200
SWI1008HT68N□□□	68	±2, ±5, ±10%	50	80 @ 350MHz	1.15	0.13	1100
SWI1008HT82N□□□	82	±2, ±5, ±10%	50	80 @ 350MHz	1.06	0.16	1100
SWI1008HTR10□□□	100	±2, ±5, ±10%	50	50 @ 350MHz	0.82	0.16	1000
SWI1008HTR12□□□	120	±2, ±5, ±10%	100	50 @ 100MHz	0.82	0.16	1000

■ Parts (3.0nH, 7.8nH) are wound on a low profile bobbin. (Max 2.41×2.01×1.09)

WIRE WOUND CHIP INDUCTOR

SWI SERIES

Size 0603 High Q & Low DCR Type (□:Tolerance) :

Part No.	Inductance (nH)	Tolerance	L Freq. (MHz)	Q typ at 250(MHz)	SRF typ (GHz)	DCR (Ω) max.	IDC (mA) max.	900MHz		1.7GHz	
								L typ	Q typ	L Typ	Q Typ
SWI0603QT1N8□□□	1.8	±5, ±10%	250	23	16.0	0.033	2100	1.77	40	1.77	65
SWI0603QT2N2□□□	2.2	±5, ±10%	250	13	15.0	0.180	900	2.14	25	2.12	35
SWI0603QT2N7□□□	2.7	±2, ±5, ±10%	250	32	15.0	0.050	900	2.70	40	2.73	75
SWI0603QT3N3□□□	3.0	±5, ±10%	250	35	9.5	0.024	1000	2.96	65	2.97	85
SWI0603QT3N3□□□	3.3	±5, ±10%	250	32	9.60	0.024	1900	3.28	67	3.32	104
SWI0603QT3N6□□□	3.6	±2, ±5, ±10%	250	40	9.70	0.031	1900	3.59	70	3.62	116
SWI0603QT3N9□□□	3.9	±2, ±5, ±10%	250	35	7.50	0.039	1600	3.88	68	3.95	108
SWI0603QT1N8□□□	4.3	±2, ±5, ±10%	250	30	7.50	0.080	1300	4.29	58	4.31	91
SWI0603QT4N7□□□	4.7	±2, ±5, ±10%	250	26	7.90	0.100	1100	4.65	48	4.71	75
SWI0603QT5N1□□□	5.1	±2, ±5, ±10%	250	40	8.90	0.036	1700	5.08	84	5.12	140
SWI0603QT5N6□□□	5.6	±2, ±5, ±10%	250	41	6.60	0.036	1700	5.6	72	5.73	95
SWI0603QT6N0□□□	6.0	±2, ±5, ±10%	250	49	6.00	0.036	1700	5.92	94	6.12	154
SWI0603QT6N8□□□	6.8	±2, ±5, ±10%	250	42	5.80	0.042	1400	6.83	88	7.05	143
SWI0603QT7N2□□□	7.2	±2, ±5, ±10%	250	48	5.40	0.052	1400	7.25	96	7.38	139
SWI0603QT7N5□□□	7.5	±2, ±5, ±10%	250	41	5.30	0.080	1300	7.55	61	7.85	72
SWI0603QT8N2□□□	8.2	±2, ±5, ±10%	250	46	5.90	0.054	1400	8.21	96	8.39	148
SWI0603QT8N7□□□	8.7	±2, ±5, ±10%	250	46	5.50	0.054	1400	8.73	97	9.00	149
SWI0603QT9N1□□□	9.1	±2, ±5, ±10%	250	40	5.10	0.037	1400	9.18	76	9.64	109
SWI0603QT9N5□□□	9.5	±2, ±5, ±10%	250	49	4.90	0.053	1400	9.56	98	9.99	149
SWI0603QT10N□□□	10	±2, ±5, ±10%	250	49	4.30	0.048	1400	10.16	90	10.64	142
SWI0603QT11N□□□	11	±2, ±5, ±10%	250	41	4.10	0.058	1400	11.06	78	11.82	108
SWI0603QT12N□□□	12	±2, ±5, ±10%	250	37	4.10	0.088	1100	12.26	69	13.2	91
SWI0603QT15N□□□	15	±2, ±5, ±10%	250	48	3.60	0.078	1200	15.41	83	17.2	124
SWI0603QT16N□□□	16	±2, ±5, ±10%	250	45	3.50	0.085	1100	16.37	77	18.7	116
SWI0603QT18N□□□	18	±2, ±5, ±10%	250	41	3.30	0.066	1200	18.56	76	20.9	100
SWI0603QT22N□□□	22	±2, ±5, ±10%	250	44	3.15	0.140	850	22.7	77	25.9	88
SWI0603QT23N□□□	23	±2, ±5, ±10%	250	40	3.00	0.183	850	24	69	29.53	80
SWI0603QT24N□□□	24	±2, ±5, ±10%	250	42	2.95	0.074	1100	24.9	77	28.9	91
SWI0603QT27N□□□	27	±2, ±5, ±10%	250	44	2.80	0.150	780	28.4	74	34.0	84
SWI0603QT30N□□□	30	±2, ±5, ±10%	250	49	2.80	0.130	920	31.5	82	37.9	82
SWI0603QT33N□□□	33	±2, ±5, ±10%	250	45	2.70	0.170	680	34.9	76	42.9	80
SWI0603QT36N□□□	36	±2, ±5, ±10%	250	44	2.50	0.225	720	38.5	69	50.0	64
SWI0603QT39N□□□	39	±2, ±5, ±10%	250	48	2.45	0.19	680	41.5	78	51.9	74
SWI0603QT43N□□□	43	±2, ±5, ±10%	250	45	2.45	0.17	810	45.7	83	58.1	76
SWI0603QT47N□□□	47	±2, ±5, ±10%	200	47	2.30	0.24	680	50.6	77	66.9	72
SWI0603QT51N□□□	51	±2, ±5, ±10%	200	49	2.30	0.28	660	54.6	73	71.3	62
SWI0603QT56N□□□	56	±2, ±5, ±10%	200	50	2.20	0.30	610	60.3	74	79.9	56
SWI0603QT68N□□□	68	±2, ±5, ±10%	200	46	2.00	0.33	600	75.5	73	113.3	49
SWI0603QT72N□□□	72	±2, ±5, ±10%	150	46	1.90	0.42	550	80.8	69	-	-
SWI0603QT75N□□□	75	±2, ±5, ±10%	150	46	1.90	0.52	500	84.6	71	-	-
SWI0603QT82N□□□	82	±2, ±5, ±10%	150	45	1.80	0.46	510	94	62	-	-
SWI0603QT91N□□□	91	±2, ±5, ±10%	150	45	1.65	0.58	440	103	64	-	-
SWI0603QTR10□□□	100	±2, ±5, ±10%	150	49	1.70	0.54	470	114	69	-	-
SWI0603QTR11□□□	110	±2, ±5, ±10%	150	47	1.60	0.58	440	126.2	63	-	-
SWI0603QTR12□□□	120	±2, ±5, ±10%	150	47	1.55	0.72	420	142.4	61	-	-
SWI0603QTR15□□□	150	±2, ±5, ±10%	150	47	1.35	0.82	390	188.8	57	-	-
SWI0603QTR18□□□	180	±2, ±5, ±10%	100	48	1.30	1.50	310	232.2	50	-	-
SWI0603QTR20□□□	200	±2, ±5, ±10%	100	47	1.25	2.00	280	265	47	-	-
SWI0603QTR21□□□	210	±2, ±5, ±10%	100	48	1.20	2.00	280	288	45	-	-
SWI0603QTR22□□□	220	±2, ±5, ±10%	100	47	1.10	2.00	280	315	41	-	-
SWI0603QTR25□□□	250	±2, ±5, ±10%	100	45	1.05	3.00	240	-	-	-	-
SWI0603QTR27□□□	270	±2, ±5, ±10%	100	46	1.05	2.25	260	-	-	-	-
SWI0603QTR30□□□	300	±2, ±5, ±10%	100	47	0.99	2.80	220	-	-	-	-
SWI0603QTR33□□□	330	±2, ±5, ±10%	100	46	0.93	3.60	180	-	-	-	-
SWI0603QTR36□□□	360	±2, ±5, ±10%	100	47	0.93	4.00	170	-	-	-	-
SWI0603QTR39□□□	390	±2, ±5, ±10%	100	47	0.88	4.00	170	-	-	-	-

[WL08\(Q\)](#) Wire Wound Chip Inductors

Inductance (nH)	Tolerance	L Freq. (MHz)	Quality Factor min.	SRF (GHz) min.	DCR (Ω) max.	IDC (mA) max.
180	$\pm 2, \pm 5, \pm 10\%$	25	45 @ 100MHz	0.750	0.35	800
4700	$\pm 2, \pm 5, \pm 10\%$	7.9	25 @ 25MHz	0.090	4.10	260

Soldering Condition

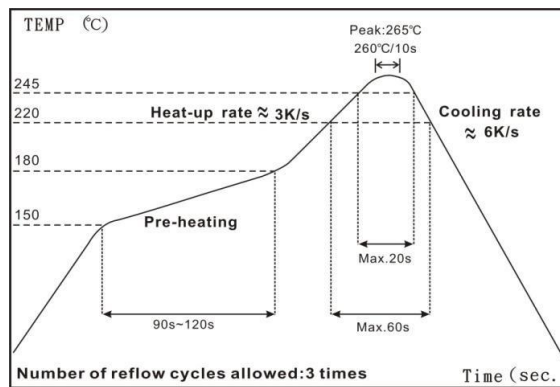

IR Reflow Soldering

(1) Time of IR reflow soldering at maximum temperature point 260°C : 10s

Environmental Characteristics

Electrical Performance Test

Item	Requirement	Test Method
Inductance	Refer to standard electrical characteristic spec.	HP4286/E4982A
Q		HP4286/E4982A
SRF		HP4287/E4982A
DC Resistance RDC		Micro-Ohm meter (Gom-801G)/E4982A
Rated Current IDC		Applied the current to coils, the temperature of coil increases $\Delta T15^{\circ}\text{C}$ ($T_a=25^{\circ}\text{C}$).
Over Load	Inductors shall have no evidence of electrical and mechanical damage	Applied 2 times of rated allowed DC current to inductor for a period of 5 minutes
Withstanding Voltage	Inductors shall be no evidence of electrical and mechanical damage.	AC voltage of 500 VAC applied between inductors terminal and case for 1 min.
Insulation Resistance	1000M ohm min.	100 V _{DC} applied between inductor terminal and case

Mechanical Performance Test

Item	Requirement	Test Method
Vibration	Appearance: No damage L change: within $\pm 5\%$ Q change: within $\pm 10\%$	Test device shall be soldered on the substrate Oscillation Frequency: 10 to 55 to 10Hz for 1 min. Amplitude: 1.5 mm Time: 2 hrs for each axis (X, Y & Z), total 6 hrs
Resistance to Soldering Heat		Solder Temperature: $260\pm 5^{\circ}\text{C}$ Immersion Time: 10 ± 2 seconds
Component Adhesion (Push Test)	1 lbs. For 0402 2 lbs. For 0603 3 lbs. For the rest	The device should be soldered ($260\pm 5^{\circ}\text{C}$ for 10 seconds) to a tinned copper subs rate. A dynamiter force gauge should be applied to the side of the component. The device must with stand a minimum force of 2 or 4 pounds without a failure of adhesion on termination
Drop	No damage	Dropping chip by each side and each corner. Drop 10 times in total Drop height: 100 cm Drop weight: 125 g
Solderability	90% covered with solder	Inductor shall be dipped in a melted solder bath at $245\pm 5^{\circ}\text{C}$ for 3 seconds
Resistance to Solvent	No damage on appearance and marking	MIL-STD-202, Method 215

Climatic Test

Item	Requirement	Item															
Temperature Characteristic	Appearance: No damage L change: within $\pm 10\%$ Q change: within $\pm 20\%$	$-40^{\circ}\text{C} \sim +125^{\circ}\text{C}$															
Humidity		Temperature: $40\pm 2^{\circ}\text{C}$ Relative Humidity: 90~95% Time: 96 ± 2 hrs Measured after exposure in the room condition for 2 hrs															
Low Temperature Storage		Temperature: $-40\pm 2^{\circ}\text{C}$ Time: 96 ± 2 hrs Inductors are tested after 1 hour at room temperature															
Thermal Shock		One cycle: <table border="1" style="margin-left: 20px;"> <thead> <tr> <th>Step</th> <th>Temperature ($^{\circ}\text{C}$)</th> <th>Time (min.)</th> </tr> </thead> <tbody> <tr> <td>1</td> <td>-25 ± 3</td> <td>30</td> </tr> <tr> <td>2</td> <td>25 ± 2</td> <td>15</td> </tr> <tr> <td>3</td> <td>125 ± 3</td> <td>30</td> </tr> <tr> <td>4</td> <td>25 ± 2</td> <td>15</td> </tr> </tbody> </table>	Step	Temperature ($^{\circ}\text{C}$)	Time (min.)	1	-25 ± 3	30	2	25 ± 2	15	3	125 ± 3	30	4	25 ± 2	15
Step		Temperature ($^{\circ}\text{C}$)	Time (min.)														
1		-25 ± 3	30														
2		25 ± 2	15														
3	125 ± 3	30															
4	25 ± 2	15															
High Temperature Storage	Temperature: $125\pm 2^{\circ}\text{C}$ Time: 96 ± 2 hrs Measured after exposure in the room condition for 1hour																
High Temperature Load Life	Temperature: $85\pm 2^{\circ}\text{C}$ Time: 1000 ± 12 hrs Load: Allowed DC current																
Damp Heat with Load	Temperature: $40\pm 2^{\circ}\text{C}$ Relative Humidity: 90~95% Time: 1000 ± 12 hrs Load: Allowed DC current																

【WL Series】

SMD Wire Wound Chip Inductor

■ Storage Temperature: 15~28°C; Humidity <80%RH

■ Packaging

Reel Dimensions & Packaging Quantity

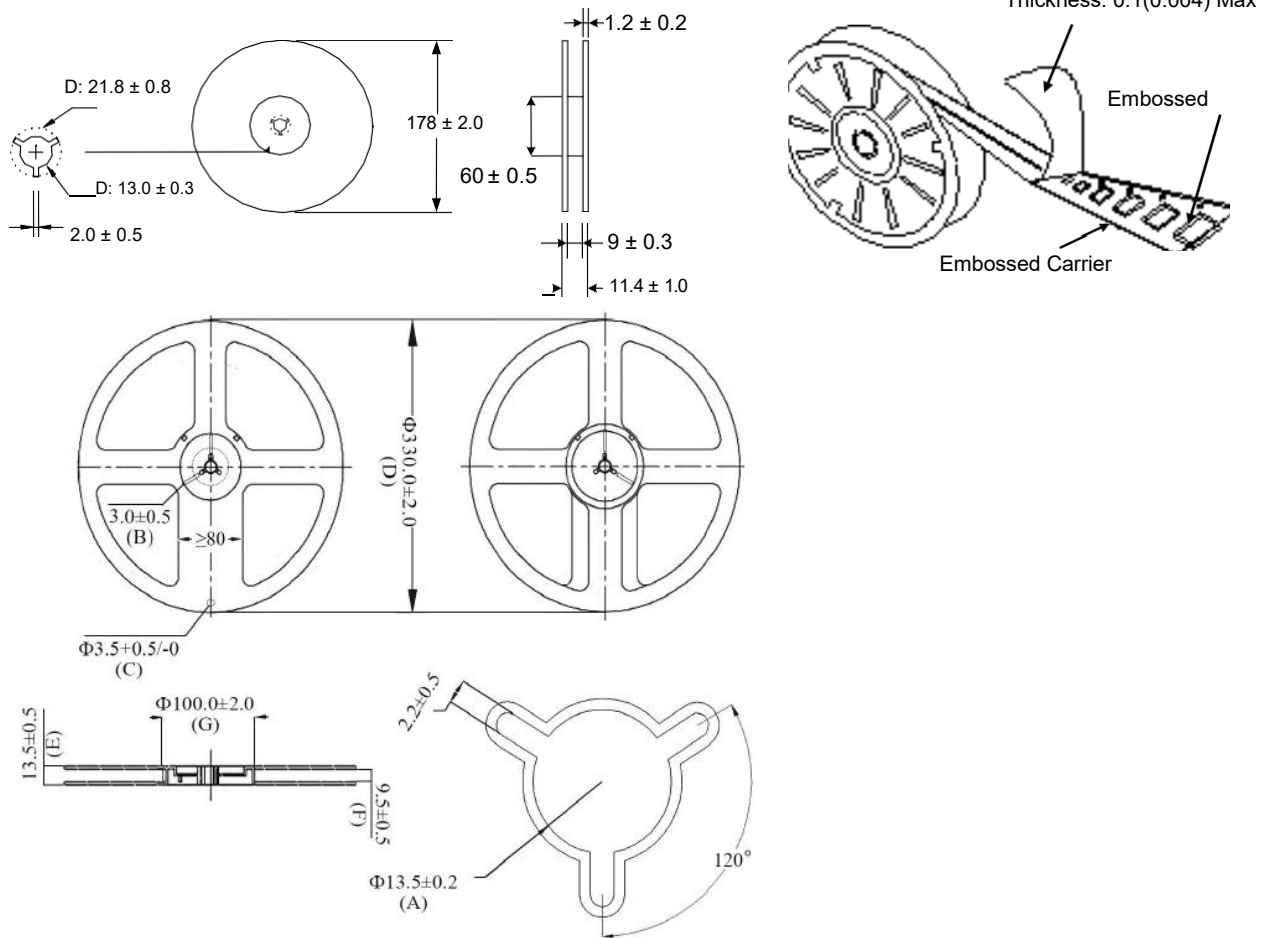

Paper Tape specification and Packaging Quantity

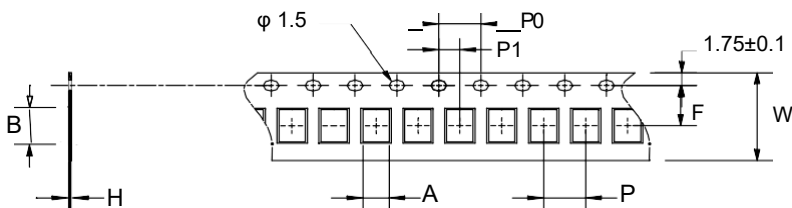

Unit: mm

Type	A	B	H	F	P	P ₀	P ₁	W	Reel (EA)
WL02	0.81	1.23	0.73	3.50	2.00	4.00	2.00	8.00	4,000
WL03	1.35	1.95	0.95	3.50	4.00	4.00	2.00	8.00	4,000/10,000

Embossed Plastic Tape specification and Packaging Quantity

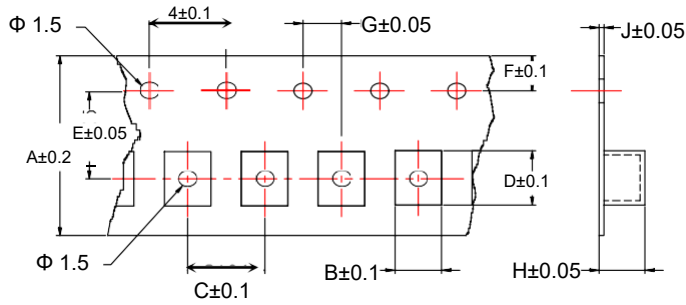

Unit: mm

Type	A	B	C	D	E	F	G	H	J	Reel (EA)
WL05	8	1.85	4	2.30	3.5	1.75	2	1.45	0.23	2,000
WL05 (H)	8	1.85	4	2.30	3.5	1.75	2	1.45	0.23	2,000
WL08	8	2.70	4	2.80	3.5	1.75	2	2.00	0.23	2,000
WL08 (H)	8	2.70	4	2.80	3.5	1.75	2	2.00	0.23	2,000